

SHEET REFERENCE

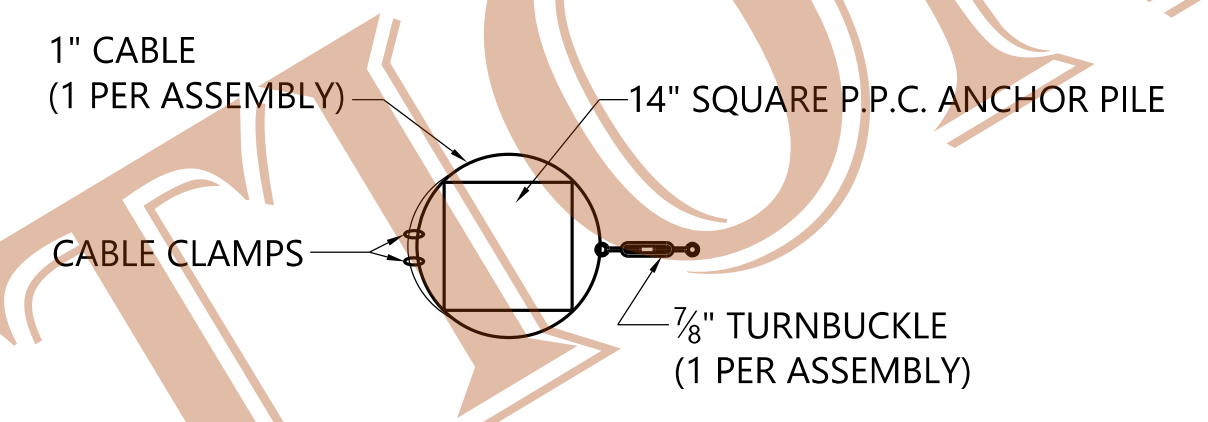

- NOTE: FACE OF PANELS SHALL BE PERMANENTLY MARKED BY FABRICATOR FOR ERECTION.
- NOTE: HORIZONTAL JOINTS BETWEEN PRECAST CONCRETE PANELS SHALL BE GROUTED. FILTER FABRIC SHALL BE PLACED BETWEEN FILL AND JOINTS.
- NOTE: REFERENCE BRIDGE DRAWINGS FOR PANELS TYPE "A" AND "W".
- NOTE: HOLES TO BE DRILLED IN PILES FOR ATTACHING CONCRETE PANELS.
- NOTE: FOR PANEL DETAILS NOT SHOWN SEE STD. DWG. NO. PCP-2400.

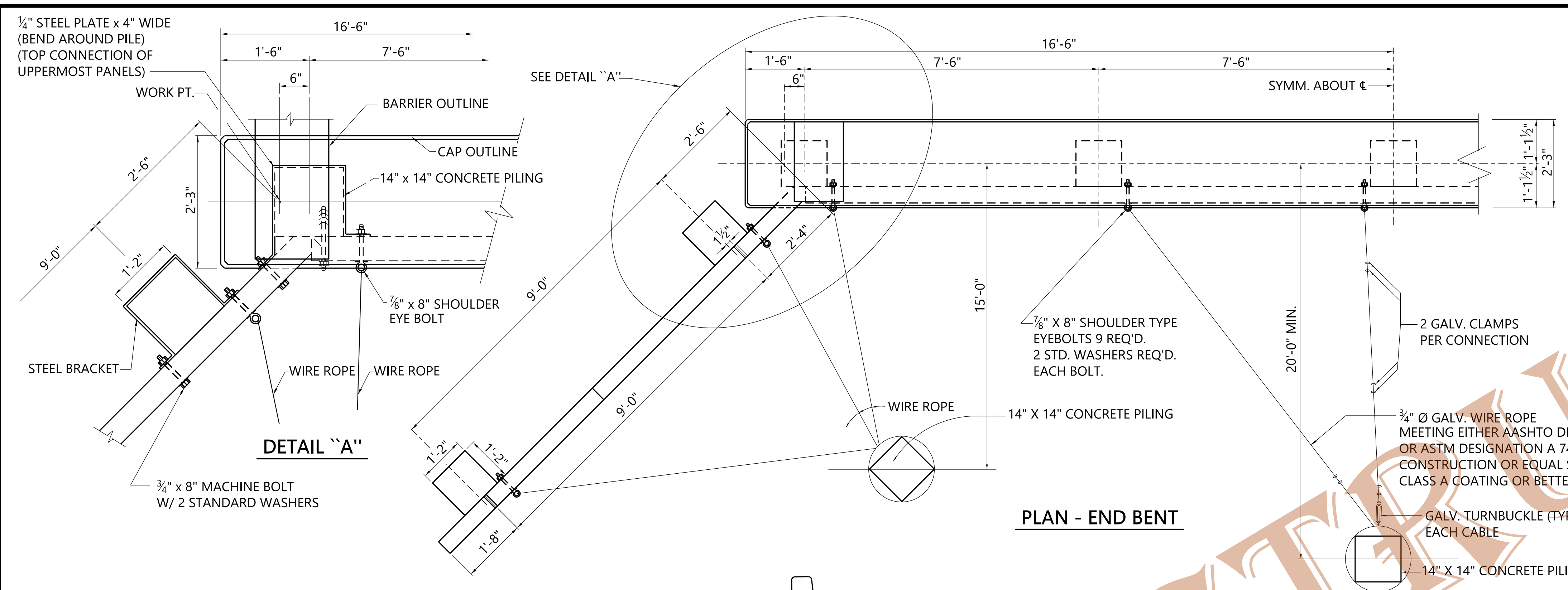
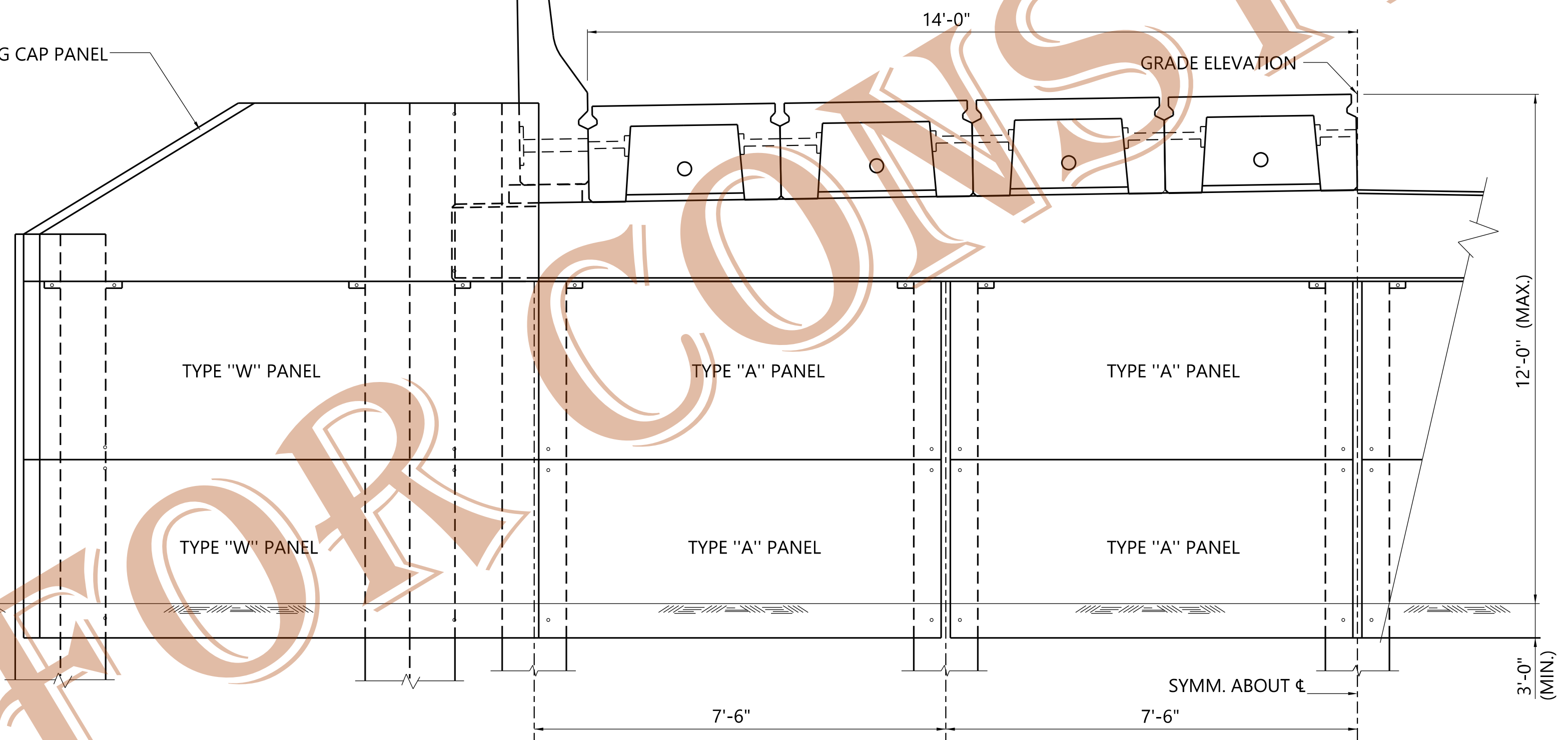

**GENERAL NOTES**

**SPECIFICATIONS:** ALABAMA DEPARTMENT OF TRANSPORTATION, CURRENT CONCRETE: CONCRETE FOR PRECAST PANELS SHALL BE IN ACCORDANCE WITH SECTION 512 OF THE STANDARD SPECIFICATIONS. ALL EXPOSED CORNERS TO BE CHAMFERED 3/4" BY 45° UNLESS OTHERWISE NOTED. ALL OTHER CORNERS ARE TO BE ROUNDED TO 1/4" RADIUS. CONCRETE WILL NOT BE PAID FOR DIRECTLY, BUT WILL BE CONSIDERED AS SUBSIDIARY TO THE ITEM PRECAST CONCRETE CAP UNIT.

**REINFORCING STEEL:** ALL REINFORCING STEEL SHALL BE ACCURATLY LOCATED IN THE FORMS AND FIRMLY HELD IN PLACE AS REQUIRED BY ITEM 502.03(c)4 OF THE STANDARD SPECIFICATIONS. REINFORCING STEEL SHALL MEET THE REQUIREMENTS OF SECTION 835 OF THE STD. SPEC. REINFORCING DIMENSIONS ARE TO THE CENTER LINE OF THE BARS UNLESS OTHERWISE NOTED. THE ABOVE STEEL WILL NOT BE PAID FOR DIRECTLY, BUT WILL BE CONSIDERED AS SUBSIDIARY TO THE ITEM OF PRECAST CONCRETE CAP UNIT.

**HARDWARE:** ALL MACHINE BOLTS CONNECTING CONCRETE ABUTMENT PANELS TO PILING SHALL BE CONSIDERED INCIDENTAL TO THE WORK. ALL BOLTS SHALL CONFORM TO ASTM A-307 AND BE GALVANIZED IN ACCORDANCE WITH ASTM A-153.

**WELDING:** ALL WELDING SHALL CONFORM TO ARTICLE 836.46 OF THE STANDARD SPECIFICATIONS.

**TOLERANCES:** A DEVIATION OF MORE THAN 1/8" MAY BE CAUSE FOR THE REJECTION OF THE UNIT.

**DESIGN DATA:** A.A.S.H.T.O. 2002 STANDARD SPECIFICATIONS FOR HIGHWAY BRIDGES AND INTERIMS SERVICE LOAD DESIGN

**BID ITEM:**  
 512-E PRECAST CONCRETE ABUTMENT PANELS, TYPE \_\_\_\_\_ EACH.  
 512-F PRECAST CONCRETE WING PANELS TYPE \_\_\_\_\_ EACH.  
 512-G PRECAST CONCRETE ABUTMENT WING CAP PANELS \_\_\_\_\_ EACH.  
 507-A WIRE ROPE ABUTMENT ANCHOR ASSEMBLY - PER EACH.

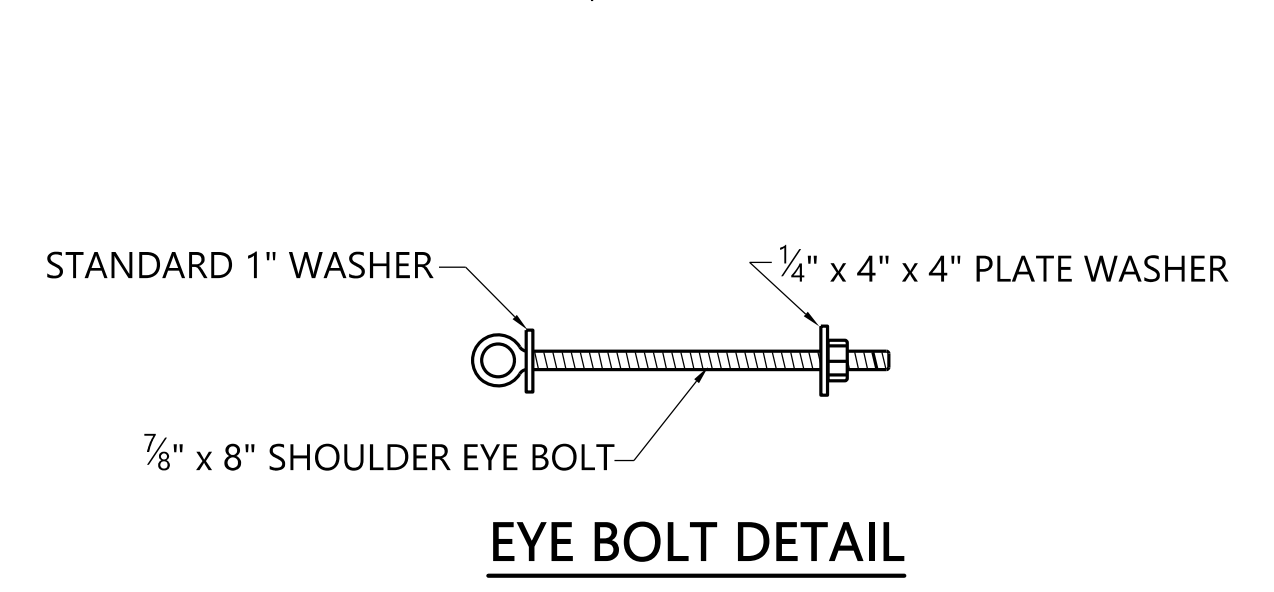
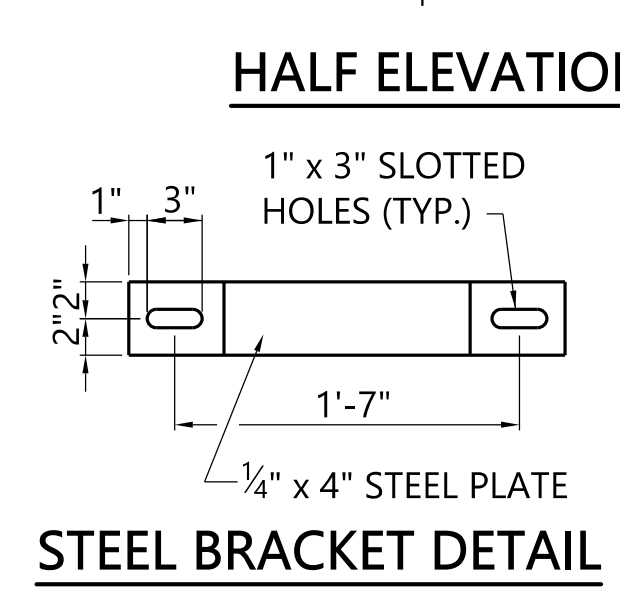
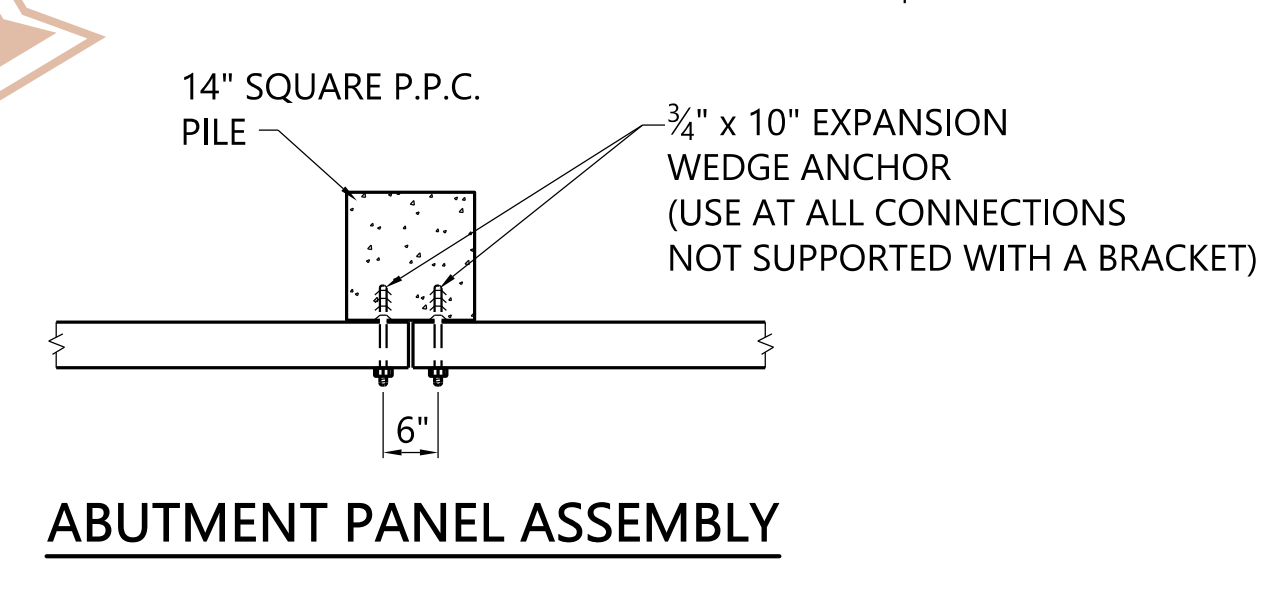
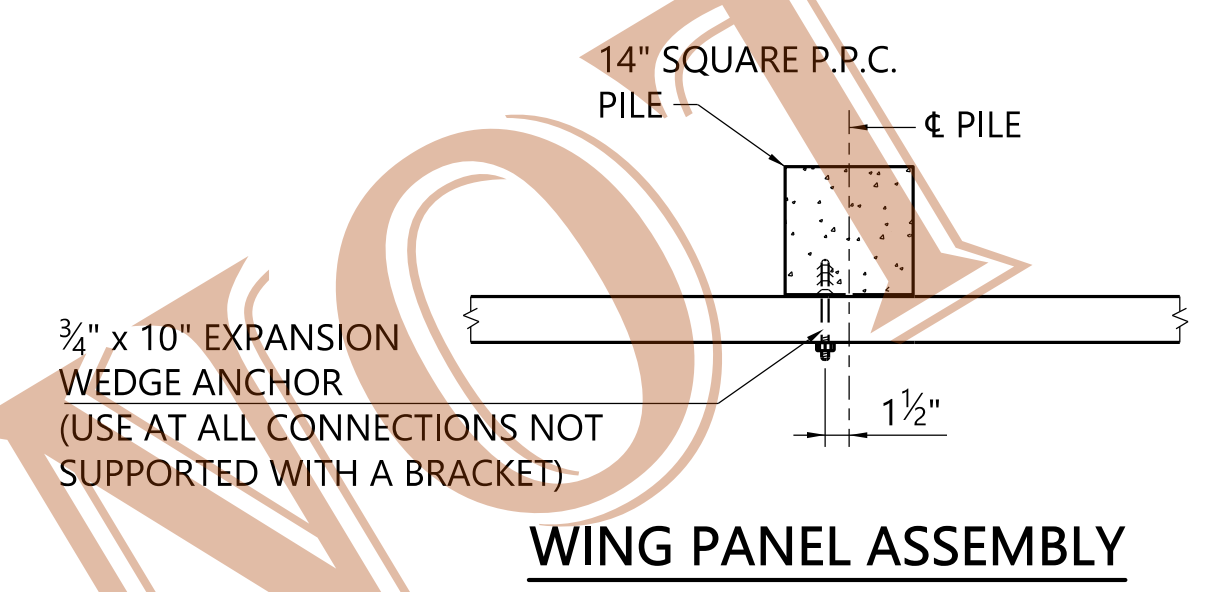

ASSISTANT BRIDGE ENGINEER <i>[Signature]</i> DATE: 11/6/22	BRIDGE ENGINEER <i>[Signature]</i> DATE: 11/7/2022
--	--

PLOTTED: 27-Dec-21 at 11:17

REVISIONS

THIS BRIDGE SPECIAL PROJECT DRAWING FOR USE ONLY ON:  
 PROJECT NO. \_\_\_\_\_  
 COUNTY(S) \_\_\_\_\_

THESE DRAWINGS REPRESENT DESIGNS PREPARED FOR USE BY THE ALABAMA DEPARTMENT OF TRANSPORTATION AND ARE NOT TO BE COPIED, REPRODUCED, ALTERED, OR USED BY ANYONE, OR ANY ORGANIZATION, WITHOUT THE EXPRESSED WRITTEN CONSENT OF THE ALABAMA DEPARTMENT OF TRANSPORTATION REPRESENTATIVE AUTHORIZED TO APPROVE SUCH USE. ANYONE MAKING UNAUTHORIZED USE OF THESE DRAWINGS MAY BE PROSECUTED TO THE FULLEST EXTENT OF THE LAW.

PRECAST CONCRETE ABUTMENT PANELS FOR USE WITH 24', 34' OR 40' PRECAST CONCRETE BRIDGE SLABS 28'-0" CLEAR ROADWAY WITH 14" x 14" CONCRETE PILING