

SIGNING PLAN DESIGN GUIDE

ALDOT DESIGN BUREAU – OCTOBER 2019

CONTENTS

- 2 OBJECTIVE
- 3 INDEX
- 6 TYPICAL SECTIONS
- 11 GENERAL NOTES
- 14 SUMMARY OF QUANTITIES
- 19 SIGN LAYOUT SHEETS
- 25 SIGN FACE DETAILS
- 75 SIGN CROSS SECTIONS SHEETS
- 80 EXAMPLES, PHOTOS, ETC

OBJECTIVE

The purpose of this guide is to develop a standard procedure for developing plans for roadway signs, ground mounted and overhead sign installations. Why is this needed?

- To show the basic requirements needed for the design of these signs.
- To aid in the consistency of the plans for these required signs on a project by project basis.
- To assure the proper placement of these signs.
- To aid in the consistency of the fabrication and installation of these signs.
- To ensure that the appearance of these signs is consistent to the traveling public.

INDEX

**THE FOLLOWING ITEMS NEED TO BE SHOWN IN THE INDEX
TO SHEETS:**

- Sign Typical Sections – to be indexed following all other typical sections as a sheet 2 series.
- General Sign Notes – to be indexed following the General Traffic Control Plan Notes as a sheet 2 series.
- Summary of Quantities Box Sheets – to be indexed following the Summary of Quantities Main Summary Sheets along with the other required box sheets as a sheet 3 series.
- Sign Layout Sheets – It is suggested that these be indexed in the plans following the Required Striping Sheets or if the Sign Layout Sheets and the Required Striping Sheets are combined, they should be indexed following the Paving Layout Sheets.
- Sign Face Detail Sheets – to be indexed following the Sign Layout Sheets.
- Sign Cross Sections – to be indexed following the Sign Face Detail Sheets.
- Project Detail Sheets – Any special project detail such as a Detail for Barrier Rail Mounted Signs. These are to be indexed along with any other required special project detail sheet before the cross section sheets.

**THE FOLLOWING SIGN RELATED STANDARD DRAWINGS
NEED TO BE SHOWN REQUIRED FROM THE STANDARD
DRAWING BOOK :**

- IHS-710-1 – Required when drawings IHS-710-2 and/or IHS-710-3 are needed.
- IHS-710-2 – Required for Class 6 ground mounted signs with posts 66” or greater apart.
- IHS-710-3 – Required for Class 6 ground mounted signs with posts 66” or less apart.
- IHS-710-12, IHS-710-21 and IHS-710-23 – Required for all projects that require Class 4, 7 and 8 signs and/or construction signs.
- IHS-710-14 – Required when a sign is required to be mounted on a barrier rail by using pipe post. (Will also require a special project detail to show details of the required post.)
- IHS-710-24 – Required when Class 6 ground mounted signs requiring multiple panels with stiffeners are needed.
- SL-710 – Required whenever R1-1 Stop signs or R1-2 Yield signs are needed in the plans.
- SHS Drawings – Include the appropriate SHS drawing needed to show the sign face detail for each type of required Class 4, 7 and 8 sign. (Example: Show drawing SHS-1 as required if a R1-1 Stop sign is needed in the plans.)

TYPICAL SECTIONS

TYPICAL SECTIONS

- Provide the typical section Standard Details for Ground Mounted Signs for all projects which include required Class 6 ground mounted signs and/or existing Class 6 ground mounted signs to be relocated. (See Figure 1)
- Provide the typical section Typical Placement for Cantilever Sign Bridges and Butterfly Mounted Overhead Signs for all projects which include required overhead cantilever and/or butterfly mounted sign structures and/or overhead cantilever and/or butterfly mounted sign structures to be relocated and/or renovated i.e. new sign panels, new supports, existing sign panels to be repositioned etc. (See Figure 2)
- Provide the typical section Typical Placement of Overhead Sign Bridge On Roadway for all projects which include required overhead sign bridge mounted sign structures and/or overhead sign bridge mounted structures to be relocated and/or renovated i.e. new sign panels, new supports, existing sign panels to be repositioned etc. (See Figure 3)
- These typical sections are available as a downloadable PDF and DGN on the Design Bureau Web Site or can be provided by the Design Bureau Traffic Design Section.

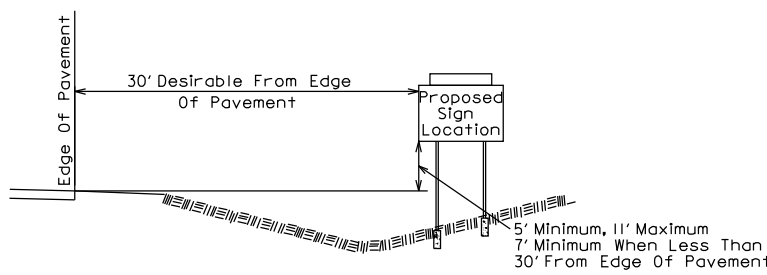

TYPICAL PLACEMENT OF SIGNS IN CUT SECTIONS

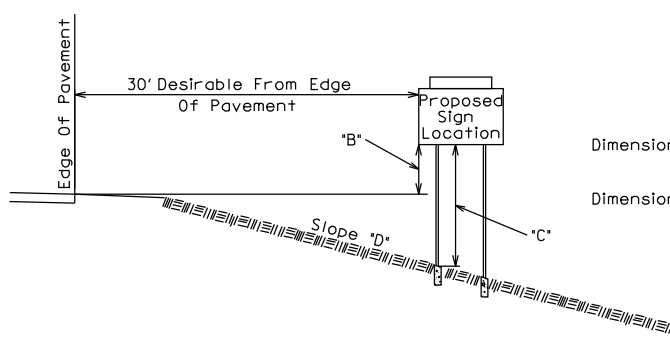

Dimension "B" - When Slope "D" is Zero, "B" = 7'-0" Minimum.
When Slope "D" is Greater Than Zero, "B" = 5'-0" Minimum.
Dimension "C" - When Slope "D" is Zero, "C" = 7'-0" Minimum.

TYPICAL PLACEMENT OF SIGNS IN CUT SECTIONS

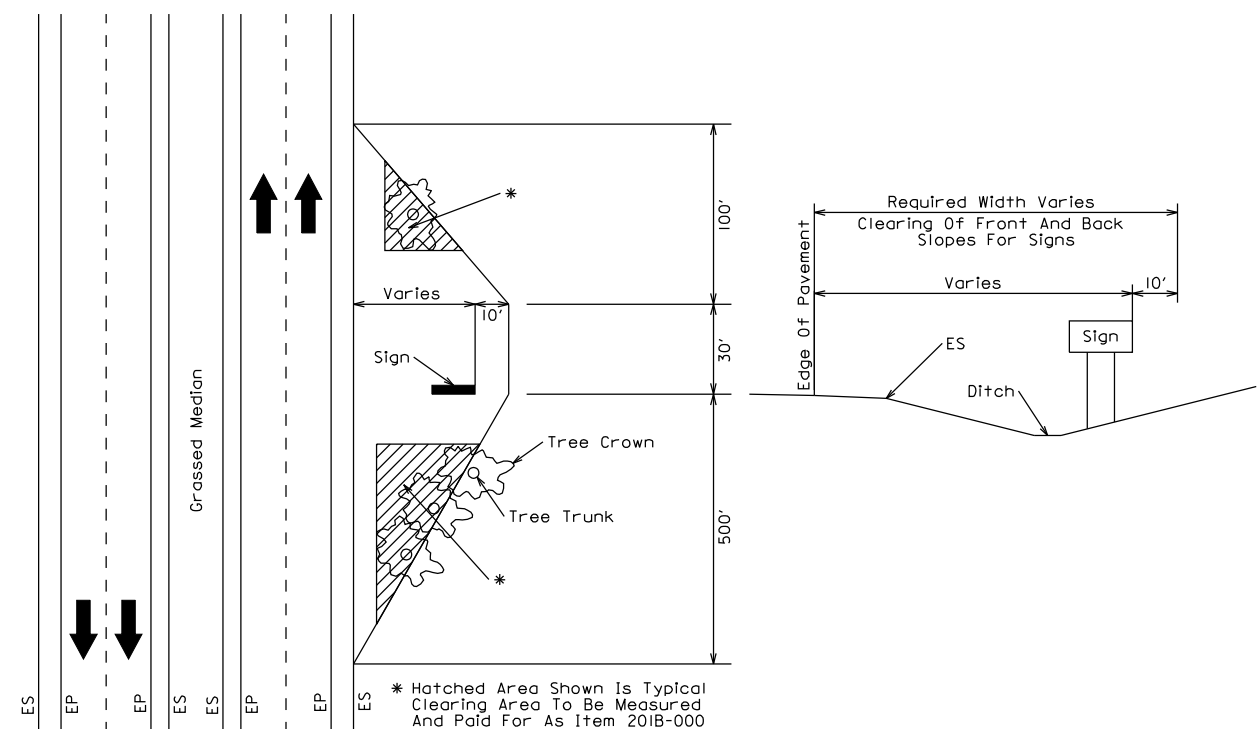

DETAIL SHOWING REQUIRED CLEARING ZONE FOR SIGNS AND DESIGNATION APPLICABLE TO SIGNS IN CUT AND FILL SECTIONS

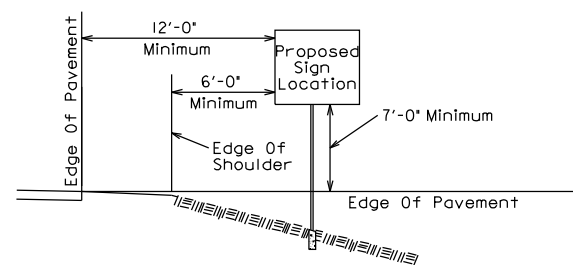

TYPICAL PLACEMENT OF SIGNS ADJACENT TO MAIN ROADWAY

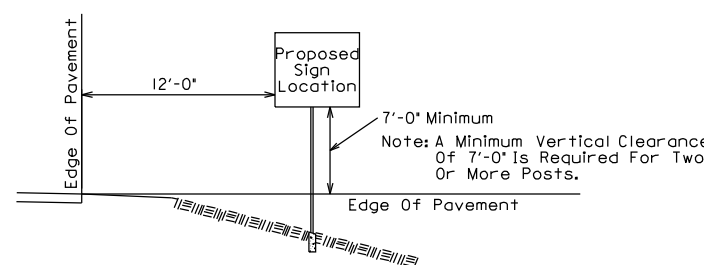

TYPICAL PLACEMENT OF SIGNS ADJACENT TO RAMPS AND CONNECTING ROADS

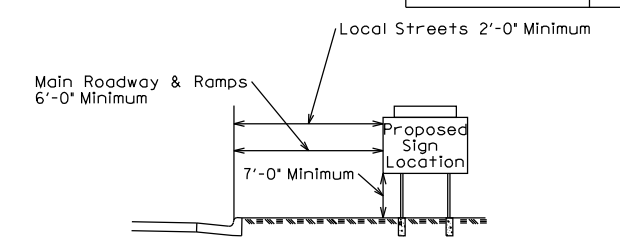

TYPICAL PLACEMENT OF SIGNS ADJACENT TO CURBED ROADWAYS

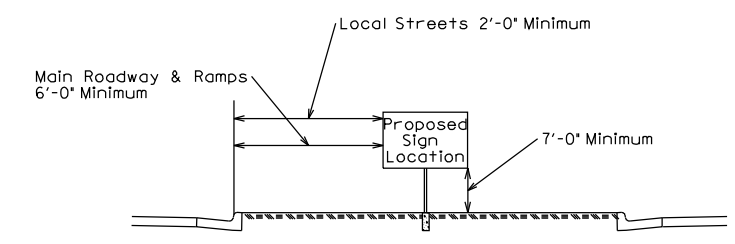

TYPICAL PLACEMENT OF SIGNS ADJACENT TO CURBED ROADWAYS

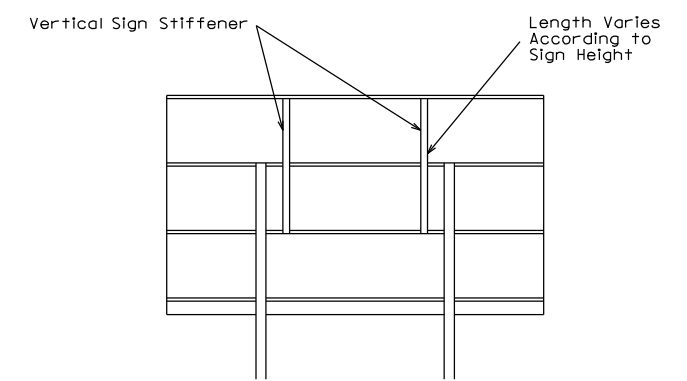

TYPICAL PLACEMENT OF VERTICAL SIGN STIFFENERS TO BE USED WITH EXISTING POST

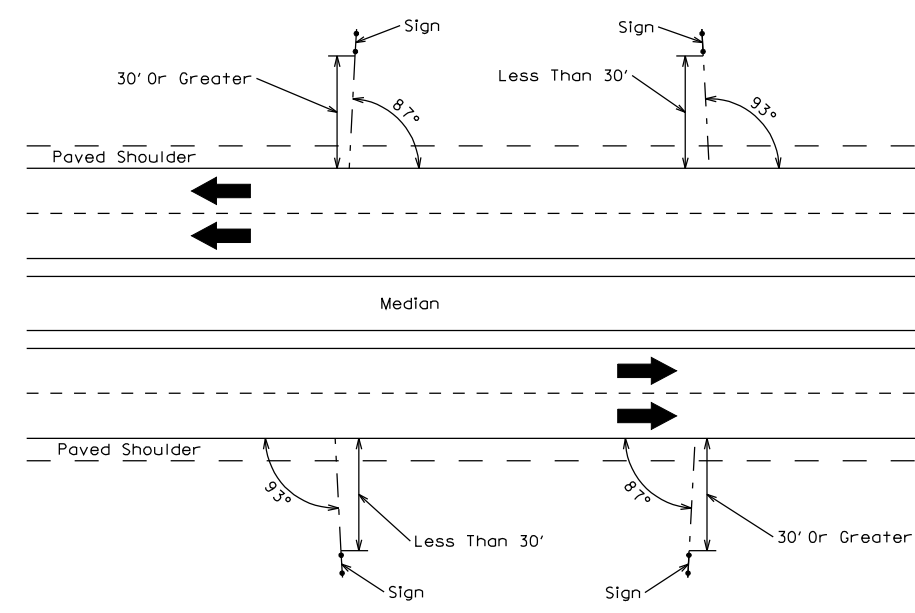

TYPICAL POSITION OF CLASS 6 SIGNS IN RELATION TO MAIN ROADWAY

--SPECIFICATIONS--
CURRENT ALABAMA DEPARTMENT OF TRANSPORTATION

THIS DRAWING REPRESENTS DESIGNS PREPARED FOR USE BY THE ALABAMA DEPARTMENT OF TRANSPORTATION AND IS NOT TO BE COPIED, REPRODUCED, ALTERED, OR USED BY ANYONE, OR ANY ORGANIZATION, WITHOUT THE EXPRESSED WRITTEN CONSENT OF THE ALABAMA DEPARTMENT OF TRANSPORTATION REPRESENTATIVE AUTHORIZED TO APPROVE THIS USE. ANYONE MAKING UNAUTHORIZED USE OF THIS DRAWING MAY BE PROSECUTED TO THE FULLEST EXTENT OF THE LAW.

REVISIONS

ALABAMA DEPARTMENT OF TRANSPORTATION
1409 COLISEUM BOULEVARD
MONTGOMERY, AL 36130-3050

DESIGN BUREAU SPECIAL DRAWING
STANDARD DETAILS FOR
GROUND MOUNTED SIGNS

SPECIAL DRAWING NO. _____ INDEX NO. _____
DRAWN BY: _____
DATE DRAWN: 1/10/2013
SPECIAL PROJECT DETAIL

FIGURE 1

NOTE: THE GUARDRAIL SHALL BE PLACED IN ACCORDANCE WITH THE DESIGN CRITERIA SHOWN ON SPECIAL DRAWING GR-630-PP.

REFERENCE PROJECT NO	FISCAL YEAR	SHEET NO

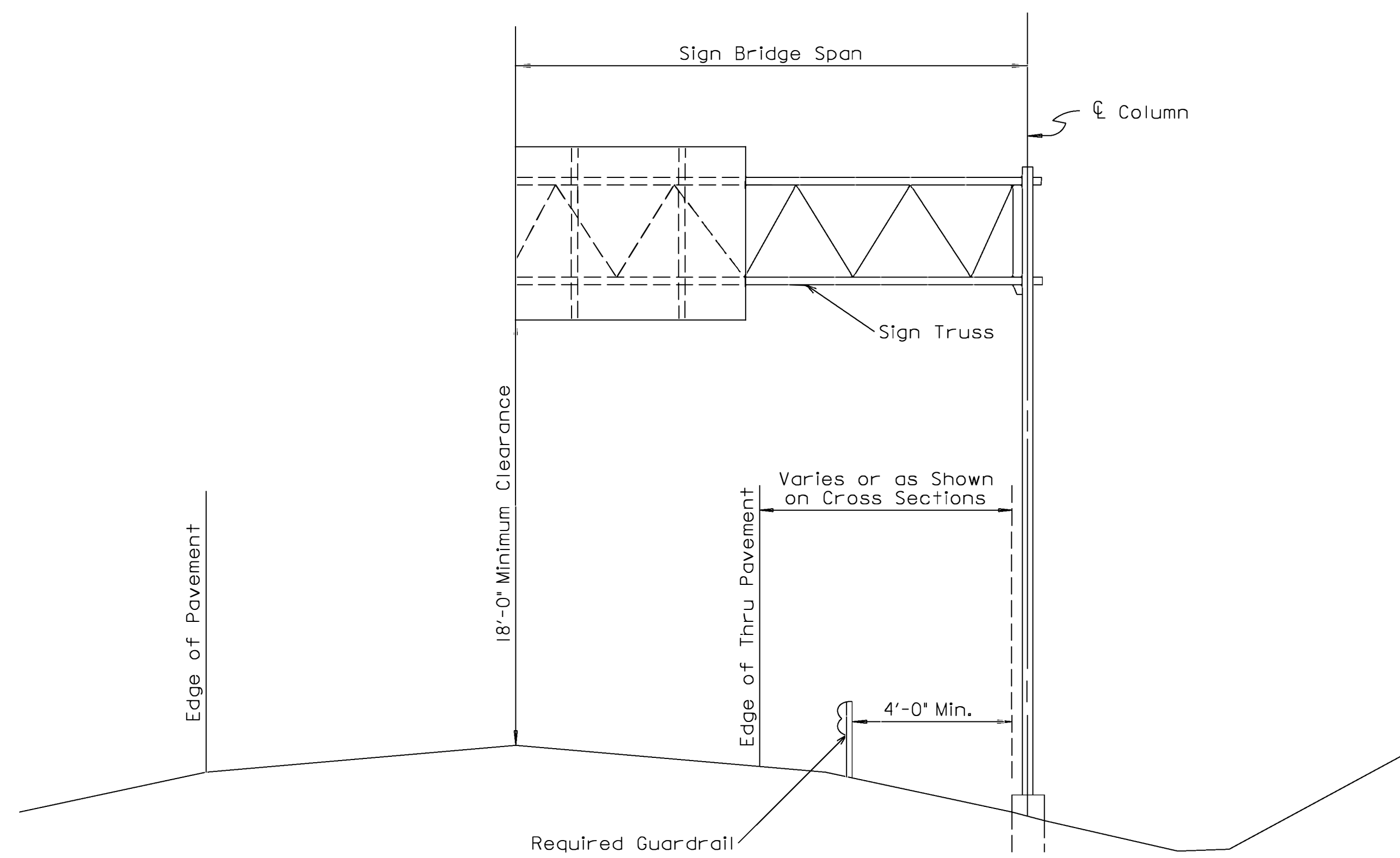

TYPICAL PLACEMENT OF CANTILEVER SIGN BRIDGE ON ROADWAY

* GUARDRAIL IS NOT SHOWN BUT MAYBE WARRANTED BASED ON SPEED, PRESENCE OF OTHER HAZARDS IN A CONSTRAINED URBAN ENVIRONMENT, OR OTHER APPLICABLE FACTORS. PROVIDE GUARDRAIL IF WARRANTED BASED ON GUIDANCE FOUND IN THE ROADSIDE DESIGN GUIDE.

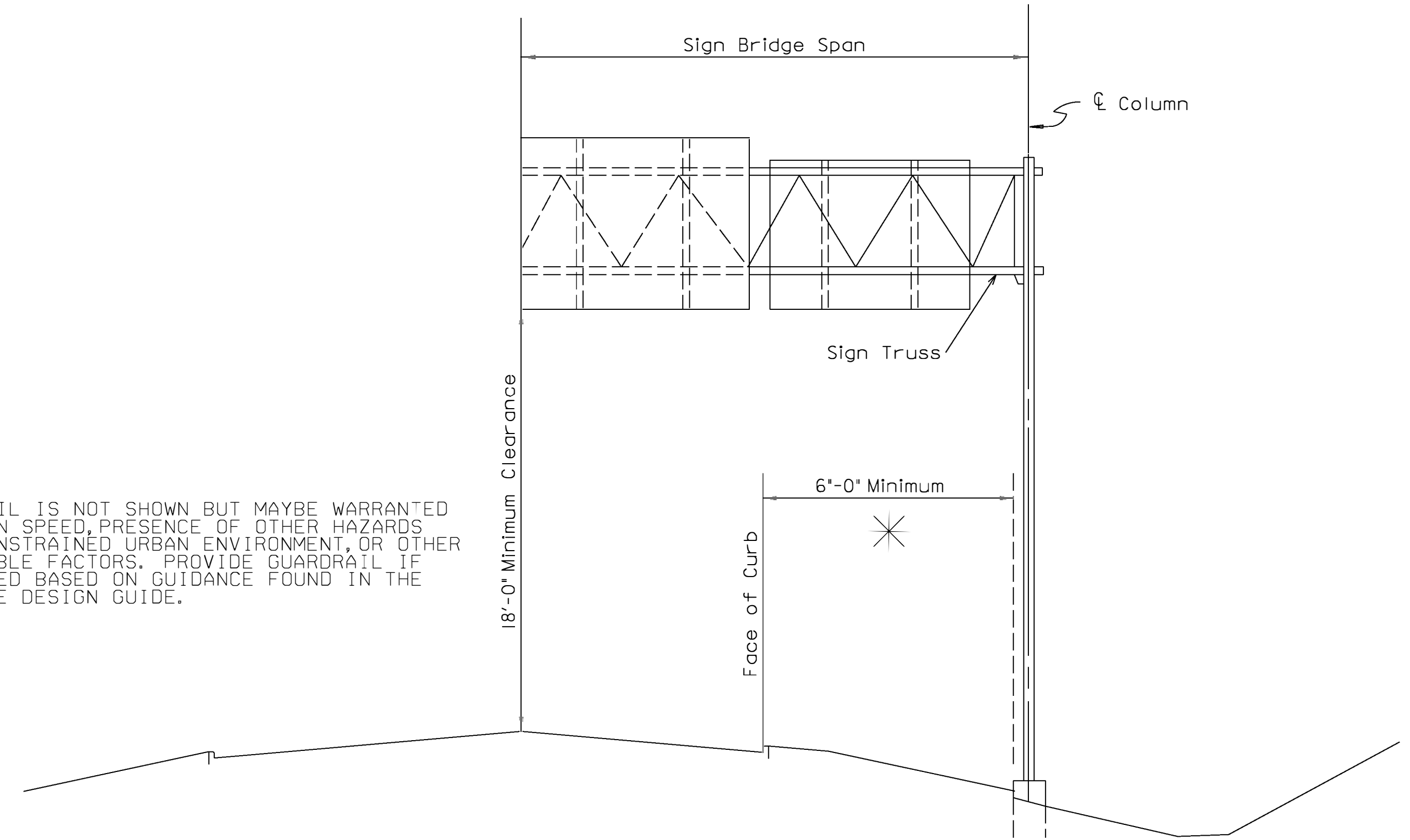

TYPICAL PLACEMENT OF CANTILEVER SIGN BRIDGE ON ROADWAYS WITH CURB & GUTTER

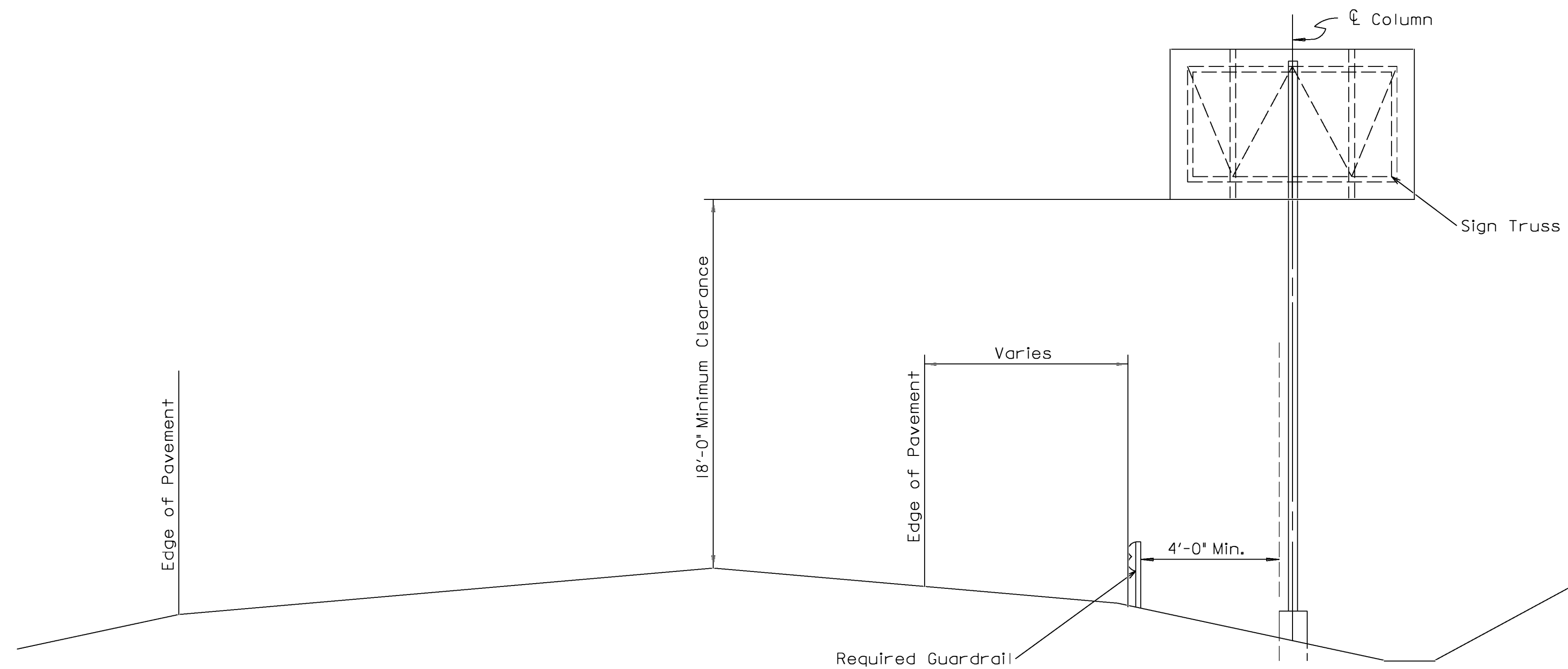

TYPICAL PLACEMENT OF BUTTERFLY MOUNTED OVERHEAD SIGNS FOR MULTILANE HIGHWAYS

--SPECIFICATIONS-- CURRENT ALABAMA DEPARTMENT OF TRANSPORTATION			
THIS DRAWING REPRESENTS DESIGNS PREPARED FOR USE BY THE ALABAMA DEPARTMENT OF TRANSPORTATION AND IS NOT TO BE COPIED, REPRODUCED, ALTERED, OR USED BY ANYONE, OR ANY ORGANIZATION, WITHOUT THE EXPRESSED WRITTEN CONSENT OF THE ALABAMA DEPARTMENT OF TRANSPORTATION REPRESENTATIVE AUTHORIZED TO APPROVE THIS USE. ANYONE MAKING UNAUTHORIZED USE OF THIS DRAWING MAY BE PROSECUTED TO THE FULLEST EXTENT OF THE LAW.			
REVISIONS	 ALABAMA DEPARTMENT OF TRANSPORTATION 1409 COLISEUM BOULEVARD MONTGOMERY, AL 36130-3050 DESIGN BUREAU SPECIAL DRAWING	TYPICAL PLACEMENT FOR CANTILEVER SIGN BRIDGES AND BUTTERFLY MOUNTED OVERHEAD SIGNS	
			SPECIAL DRAWING NO. SPECIAL PROJECT DETAIL
DRAWN BY: _____ DATE DRAWN: 9-18-19	SHEET TITLE		ROUTE



REFERENCE PROJECT NO	FISCAL YEAR	SHEET NO

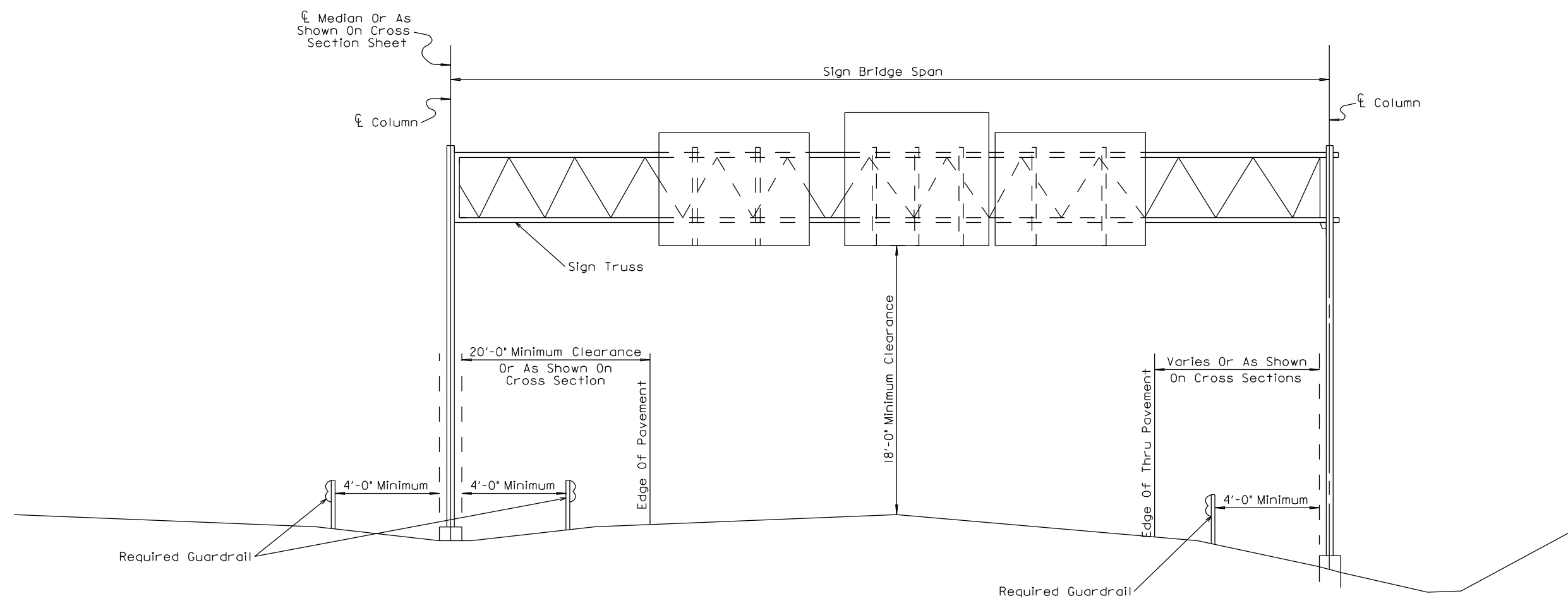

TYPICAL PLACEMENT OF OVERHEAD SIGN BRIDGE ON ROADWAY

NOTE: THE GUARDRAIL SHALL BE PLACED IN ACCORDANCE WITH THE DESIGN CRITERIA SHOWN ON SPECIAL DRAWING GR-630-PP.

--SPECIFICATIONS--
CURRENT ALABAMA DEPARTMENT OF TRANSPORTATION

THIS DRAWING REPRESENTS DESIGNS PREPARED FOR USE BY THE ALABAMA DEPARTMENT OF TRANSPORTATION AND IS NOT TO BE COPIED, REPRODUCED, ALTERED, OR USED BY ANYONE, OR ANY ORGANIZATION, WITHOUT THE EXPRESSED WRITTEN CONSENT OF THE ALABAMA DEPARTMENT OF TRANSPORTATION REPRESENTATIVE AUTHORIZED TO APPROVE THIS USE. ANYONE MAKING UNAUTHORIZED USE OF THIS DRAWING MAY BE PROSECUTED TO THE FULLEST EXTENT OF THE LAW.

REVISIONS

ALABAMA DEPARTMENT OF TRANSPORTATION
1409 COLISEUM BOULEVARD
MONTGOMERY, AL 36130-3050

DESIGN BUREAU SPECIAL DRAWING
TYPICAL PLACEMENT OF OVERHEAD SIGN BRIDGE ON ROADWAY

SPECIAL DRAWING NO. _____ INDEX NO. _____
DRAWN BY: _____
DATE DRAWN: 1-10-2013

SPECIAL PROJECT DETAIL

FIGURE 3



NOT TO SCALE

SHEET TITLE	ROUTE
10	

GENERAL NOTES

GENERAL SIGN NOTES

- Provide a copy of the ALDOT General Signing Plan Notes in all projects which require Class 6 (ground mounted or overhead) or Class 2A signs. (See Figure 4) Read each note and circle the notes required for the project.
- Please note that some notes shown on the sheet may need to be revised as needed depending on the nature of the project. Any revisions needed to the notes will be provided at the Plan-In-Hand and/or the PS&E Inspections.
- These notes are available as downloadable DGN and PDF files on the Design Bureau Web Site or can be provided by the Design Bureau Traffic Design Section.

GENERAL SIGNING PLAN NOTES

REFERENCE PROJECT NO	FISCAL YEAR	SHEET NO
----------------------	-------------	----------

○ DENOTES NOTES THAT APPLY TO THIS PROJECT

- | | |
|---|--|
| <p>1000 FINAL LENGTHS OF POSTS SHALL BE DETERMINED IN THE FIELD BY ACCURATE CROSS SECTIONS BY THE ENGINEER AND THESE LENGTHS FURNISHED TO THE CONTRACTOR.</p> <p>1001 MARGIN DIMENSIONS SHOWN ON THE PLANS MAY BE VARIED AS MUCH AS 20% WHEN NECESSITATED BY MINOR DIFFERENCES IN MANUFACTURE OF COPY.</p> <p>1002 SLIGHT ADJUSTMENTS IN THE LOCATION OF PROPOSED SIGNS WILL BE PERMITTED WHEN NECESSARY TO ELIMINATE CONFLICTS WITH EXISTING UTILITIES OR AT THE DIRECTION OF THE PROJECT ENGINEER TO TAKE ADVANTAGE OF BETTER TERRAIN LOCATION. THIS DETERMINATION WILL BE MADE BY THE PROJECT ENGINEER AT THE TIME THAT FINAL STAKEOUT IS MADE FOR CONSTRUCTION. HOWEVER, IT WILL BE THE CONTRACTORS RESPONSIBILITY TO VERIFY THE LOCATION OF ALL UTILITY LINES IN THE CONSTRUCTION AREA PRIOR TO BEGINNING WORK. ANY DAMAGE TO UTILITIES WILL BE REPAIRED BY THE CONTRACTOR AT HIS EXPENSE.</p> <p>1004 IN CASES WHERE NEW PANELS ARE PLACED ON EXISTING POSTS OR WHERE NEW PANELS ARE TO BE PLACED ON NEW POSTS, THE EXISTING ASSEMBLY WILL REMAIN IN PLACE UNTIL SUCH TIME AS THE NEW PANELS AND NEW POSTS ARE READY FOR PANEL PLACEMENT.</p> <p>1005 WHERE NEW PANELS ARE PLACED ON EXISTING POSTS, PAYMENT SHALL BE FOR THE NEW PANELS ONLY. THE COST OF CUTTING THE EXISTING POSTS TO THEIR PROPER LENGTHS, NECESSARY HARDWARE, ECT. SHALL BE CONSIDERED A SUBSIDIARY OBLIGATION OF ITEM 710A.</p> <p>1006 THE CONTRACTOR SHALL BE REQUIRED TO SAW CUT THE EXISTING POST AS REQUIRED TO FIT THE NEW PANEL ASSEMBLY AND THE CUT ENDS REGALVANIZED AS DIRECTED BY THE ENGINEER. BURNING POSTS WILL NOT BE ALLOWED.</p> <p>1007 ON OVERHEAD SIGN RENOVATION, ANY LIGHTS ENCOUNTERED SHALL BE REMOVED AND STOCKPILED IN AN AREA DESIGNATED BY THE ENGINEER FOR STATE FORCES TO PICK UP. WALKWAYS SHALL REMAIN IN PLACE. THIS SHALL BE A SUBSIDIARY OBLIGATION OF ITEM 711A. POWER SHALL BE SHUT OFF AT THE DISCONNECT SWITCH.</p> <p>1008 POSTS SHALL BE REMOVED A MINIMUM OF 1' (ONE FOOT) BELOW THE EXISTING GROUND LINE. ANY NECESSARY EXCAVATION AND/OR BACKFILL SHALL BE A SUBSIDIARY OBLIGATION OF ITEM 710A.</p> <p>1009 THE CONTRACTOR SHALL USE THE CROSSOVERS DESIGNATED FOR EMERGENCY VEHICLES OR ONES APPROVED BY THE ENGINEER.</p> <p>1010 IN SOME INSTANCES, SIGN PANELS AND POSTS HAVE BEEN REMOVED OR DESTROYED PRIOR TO THIS CONTRACT LEAVING SLOPE PAVED APRONS, BASE CONNECTIONS, FOOTINGS, ETC. IN SUCH CASES, THEY SHALL BE REMOVED IN THE SAME MANNER AS EXISTING SIGNS AND CONSIDERED A SUBSIDIARY OBLIGATION OF ITEM 710C.</p> <p>1011 ANY DAMAGE TO EXISTING TURF, FLUMES, SLOPE PAVING, UNDERDRAIN PIPE, OUTLETS, ELECTRICAL CONDUIT OR OTHER EXISTING FEATURES BY THE CONTRACTOR DURING THE COURSE OF THE WORK PROVIDED IN THIS CONTRACT SHALL BE REPAIRED OR REPLACED BY THE CONTRACTOR WITHOUT COST TO THE STATE.</p> <p>1012 RETAINED POSTS ON RELOCATED OR REHABILITATED SIGNS SHALL BE CLEANED AND COLD GALVANIZED WHERE RUST AREAS OCCUR AND WHERE POSTS ARE CUT OFF TO FIT REQUIRED SIGN PANELS. ALL DAMAGED OR MISSING BOLTS AND NUTS SHALL BE REPLACED AND RETORQUED. THIS SHALL BE A SUBSIDIARY OBLIGATION OF ITEM 710A.</p> <p>1013 WHERE EXISTING PANELS ARE TO BE RETAINED AND PLACED ON NEW POSTS, THE COST OF INSTALLING THE SIGN PANEL SHALL BE A SUBSIDIARY OBLIGATION OF ITEM 710B.</p> <p>1014 UPRIGHT BASE PLATE CONNECTION WELDS SHALL BE INSPECTED BY THE FABRICATOR IN ACCORDANCE WITH THE AASHTO "STANDARD SPECIFICATIONS FOR STRUCTURAL SUPPORTS FOR HIGHWAY SIGNS, LUMINARIES AND TRAFFIC SIGNALS" LATEST EDITION.</p> <p>1015 CIRCUMFERENTIAL WELDED SPLICES SHALL NOT BE USED ON ANY OVERHEAD SIGN STRUCTURE.</p> | <p>1016 WHERE NEW PANELS ARE PLACED ON EXISTING OVERHEAD SIGN STRUCTURES, PAYMENT SHALL BE FOR THE NEW PANELS ONLY. THE COST OF CUTTING OR REPLACING THE UPRIGHTS FOR MOUNTING THE SIGNS SHALL BE A SUBSIDIARY OBLIGATION OF ITEM 710A. THE COST OF ADDITIONAL UPRIGHTS FOR MOUNTING THE SIGNS SHALL BE A SUBSIDIARY OBLIGATION OF ITEM 710E.</p> <p>1017 THE CONTRACTOR SHALL NOT PERFORM ANY WORK ON LOUVERED SIGNS FOR THE ENTIRE PROJECT AREA. THIS SHALL INCLUDE LUMINARIES ON LOUVERED SIGNS.</p> <p>1018 ANY REFERENCES TO OVERLAY PANELS OR OVERLAY PANEL SHEETS SHALL BE DISREGARDED.</p> |
|---|--|

Figure 4

THIS DRAWING REPRESENTS DESIGNS PREPARED FOR USE BY THE ALABAMA DEPARTMENT OF TRANSPORTATION AND IS NOT TO BE COPIED, REPRODUCED, ALTERED, OR USED BY ANYONE, OR ANY ORGANIZATION, WITHOUT THE EXPRESSED WRITTEN CONSENT OF THE ALABAMA DEPARTMENT OF TRANSPORTATION REPRESENTATIVE AUTHORIZED TO APPROVE THIS USE. ANYONE MAKING UNAUTHORIZED USE OF THIS DRAWING MAY BE PROSECUTED TO THE FULLEST EXTENT OF THE LAW.		
REVISIONS 1. Deleted Note #1003 about estimating foundation size for ground mounting signs and overhead signs on 9/30/15 by LVS.	 ALABAMA DEPARTMENT OF TRANSPORTATION 1409 COLISEUM BOULEVARD MONTGOMERY, AL 36130-3050 DESIGN BUREAU SPECIAL DRAWING	
DRAWN BY: _____ DATE DRAWN: 01/14/2013	SPECIAL DRAWING NO. SPECIAL PROJECT DETAIL	INDEX NO. 1000

FIGURE 4

SUMMARY OF QUANTITIES

SUMMARY OF QUANTITIES

- A box will need to be provided for all required roadway signs. This box should show the following information:
 - a. A sign identification number for each required sign assembly which corresponds with the number shown on the sign layout sheet.
 - b. The roadway the assembly is required on.
 - c. The side of traffic that the assembly is to be placed.
 - d. The type of posts required for the sign assembly.
 - e. The number of posts required for the assembly.
 - f. Each type of sign required for the assembly.
 - g. The standard drawings required for the assembly.
 - h. The required pay items which show the square foot total for each sign assembly.
 - i. A remarks column to show any additional information needed.

See Figure 5 for an example of this box. This box is usually what is needed for regular roadway signs unless ground mounted directional, destination or overhead sign assemblies are required for the project.

- See Figure 6 for an example of a box for regular roadway signs and ground mounted directional and/or destination signs.
- All required overhead sign structures will require a separate box. See Figure 7 for an example of this box.
- While most designers use spread sheets to create their required boxes, the appearance of the boxes should resemble the above referenced figures.

SUMMARY OF QUANTITIES

REFERENCE PROJECT NO	FISCAL YEAR	SHEET NO
BR-0074(517)	2018	3F

REQUIRED CLASS 4 AND CLASS 8 ROADWAY SIGNS, ROADWAY SIGN POST AND MILE POST																						
STATION	ROADWAY	SIGN ID	SIDE	NO OF POSTS	710B-021	R1-1	R5-1	R5-1A	R6-3	M1-4	M1-6	M2-1	M3-1	M4-5	M6-1L	M6-1R	W8-13	W14-1	710A-115	710A-126	SPECIAL AND STANDARD HIGHWAY DRAWINGS	REMARKS
					ROADWAY SIGN POST (*3 U CHANNEL, GALVANIZED STEEL OR 2", 14 GA SQUARE TUBULAR STEEL)														CLASS 4, ALUMINUM FLAT SIGN PANELS 0.08" THICK OR STEEL FLAT SIGN PANELS 14 GAUGE (TYPE III OR TYPE IV BACKGROUND)	CLASS 8, ALUMINUM FLAT SIGN PANELS 0.08" THICK OR STEEL FLAT SIGN PANELS 14 GAUGE (TYPE IX BACKGROUND)		
					LIN FT	36" X36"	36" X36"	36" X24"	30" X24"	30" X24"	24"	30" X15"	36" X18"	24" X12"	21" X15"	21" X15"	36" X36"	30" X30"	SQ FT	SQ FT		
123+46.61	CONST	1	RT	1	14	7.46											1		9	0	A B C H	
132+91.68	CONST	2	RT	1	14			1			1	1							9.91	6	A B C F J K	
137+99.24	CONST	3	RT	1	14		1								1				8.97	9	A B C F J K L	CR 1605
138+70.14	CONST	4	RT	1	14	1			1										0	12.46	A B C D E G	
153+74.08	CONST	5	RT	1	14			1		1	1								9.91	6	A B C F J K	CR 1618
156+65.21	CONST	6	RT	1	14					1	1				1				8.97	0	A B C J K L	CR 1618
158+42.80	CONST	7	RT	1	14			1		1	1								9.91	6	A B C F J K	CR 1617
159+88.97	CONST	8	RT	1	14					1	1				1				8.97	0	A B C J K L	CR 1617
	CR 723	9	LT	1	14													1	6.25	0	A B C I	
	CR 723	10	LT	1	14					1				1					9.19	0	A B C J K L	US 278
160+78.84	CONST	11	RT	1	14		1												0	9	A B C F	
160+78.22	CONST	12	MED	1	14		1												0	9	A B C F	
44+17.52	CR 724	13	RT	1	14	1			1										0	12.46	A B C D E G	
	CR 725	14	RT	1	14					1				1	1				9.19	0	A B C J K L	US 278
	CR 725	15	LT	1	14					1				1		1			9.19	0	A B C J K L	US 278
162+84.39	CONST	16	LT	1	14					1		1				1			8.97	0	A B C J K L	CR 1617
166+96.54	CONST	17	LT	1	14			1		1	1	1							9.91	6	A B C F J K	CR 1617
TOTAL					238														119	76		

FIGURE 5

SPECIAL & STANDARD DRAWINGS	
A	IHS-710-12
B	IHS-710-21
C	IHS-710-23
D	SL-710
E	SHS-1
F	SHS-3
G	SHS-4
H	SHS-15
I	SHS-18
J	SHS-19
K	SHS-20
L	SHS-21

SIGN LAYOUT SHEETS

SIGN LAYOUT SHEETS

- Show required and existing sign assemblies.
- Show a sign identification number for each required sign assembly, or an existing sign assembly that requires some type of modification such as:
 - a. A sign panel to be retained but placed on new posts.
 - b. A sign panel to be relocated to a new location.
 - c. A new panel to be placed on existing posts.

Provide a sign identification number for each assembly, not for each individual sign panel required for the assembly.

- All panels required in a sign assembly should be shown on the sheets as they face traffic.
- Indicate the disposition of existing signs shown on the sheets (i.e. remove sign assembly, relocate sign assembly, replace posts only, replace panel only). Symbols and Legends may be used to show this.
- Show existing sign panels as dashed and required sign panels as solid.
- See Figures 8 – 8C for examples of sign layout sheets.

SIGNING & STRIPING LAYOUT

REFERENCE PROJECT NO	FISCAL YEAR	SHEET NO
ACIM59761-ATRP(001)	2014	35

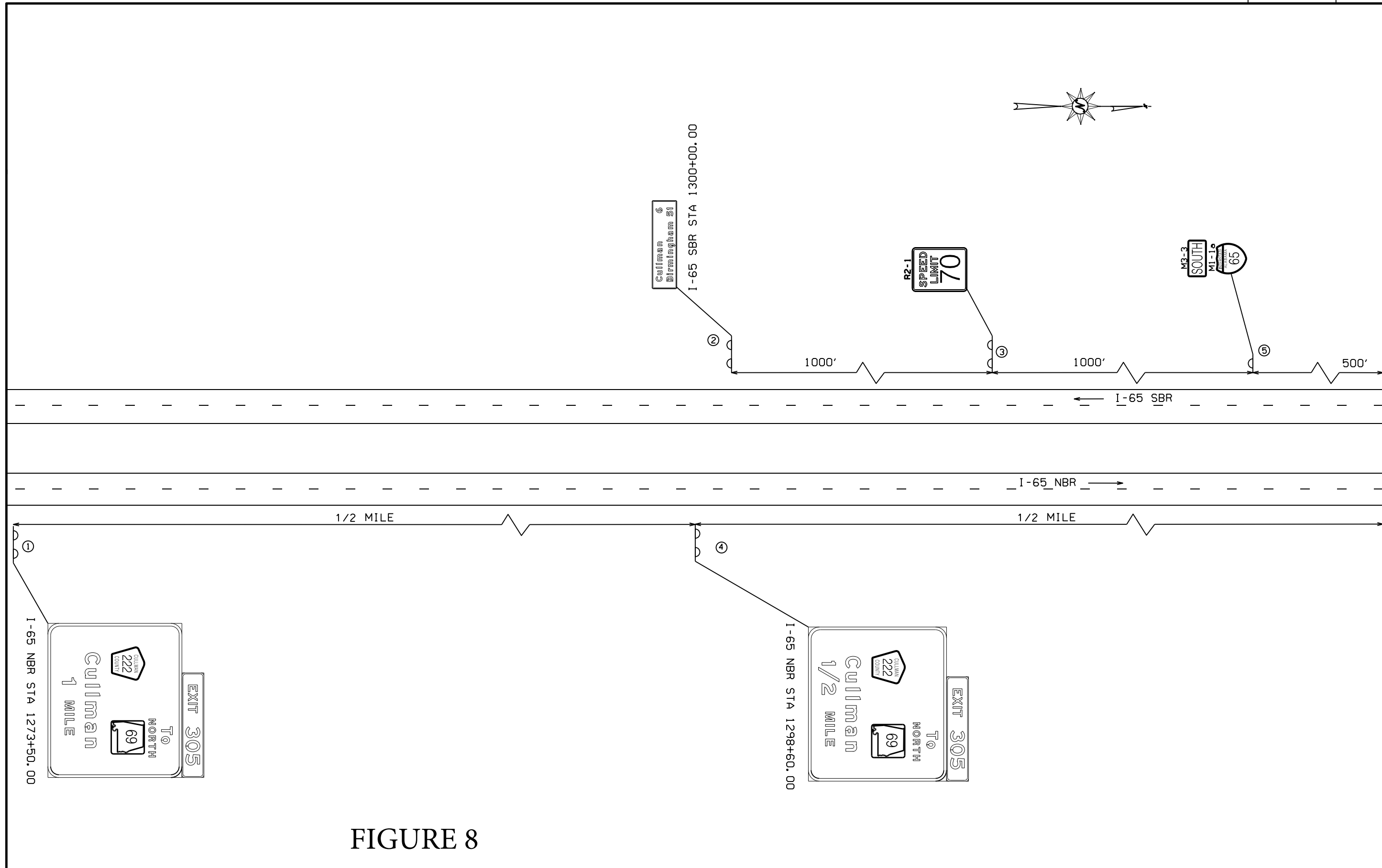

FIGURE 8

SDATES \$TIMES \$USER NAMES \$\$\$DESIGN FILE SPECIFICATION\$\$\$

RESPONSIBLE PE:	SUPERVISOR:	DESIGNER:	PLAN SUBMITTAL	 ALABAMA DEPARTMENT OF TRANSPORTATION DESIGN BUREAU SECTION D3	NOT TO SCALE	SHEET TITLE	ROUTE
DATE:	DATE:	DATE:	OE			SIGNING AND STRIPING LAYOUT	21

SIGNING & STRIPING LAYOUT SHEET

REFERENCE PROJECT NO	FISCAL YEAR	SHEET NO
ACIM59761-ATRP(001)	2014	35A

- Ⓐ SOLID WHITE, CLASS 2, TYPE A TRAFFIC STRIPE (5' WIDE)
- Ⓑ BROKEN WHITE, CLASS 2, TYPE A TRAFFIC STRIPE (5' WIDE)
- Ⓒ DOTTED WHITE, CLASS 2, TYPE A TRAFFIC STRIPE (5' WIDE)
- Ⓓ SOLID YELLOW, CLASS 2, TYPE A TRAFFIC STRIPE (5' WIDE)

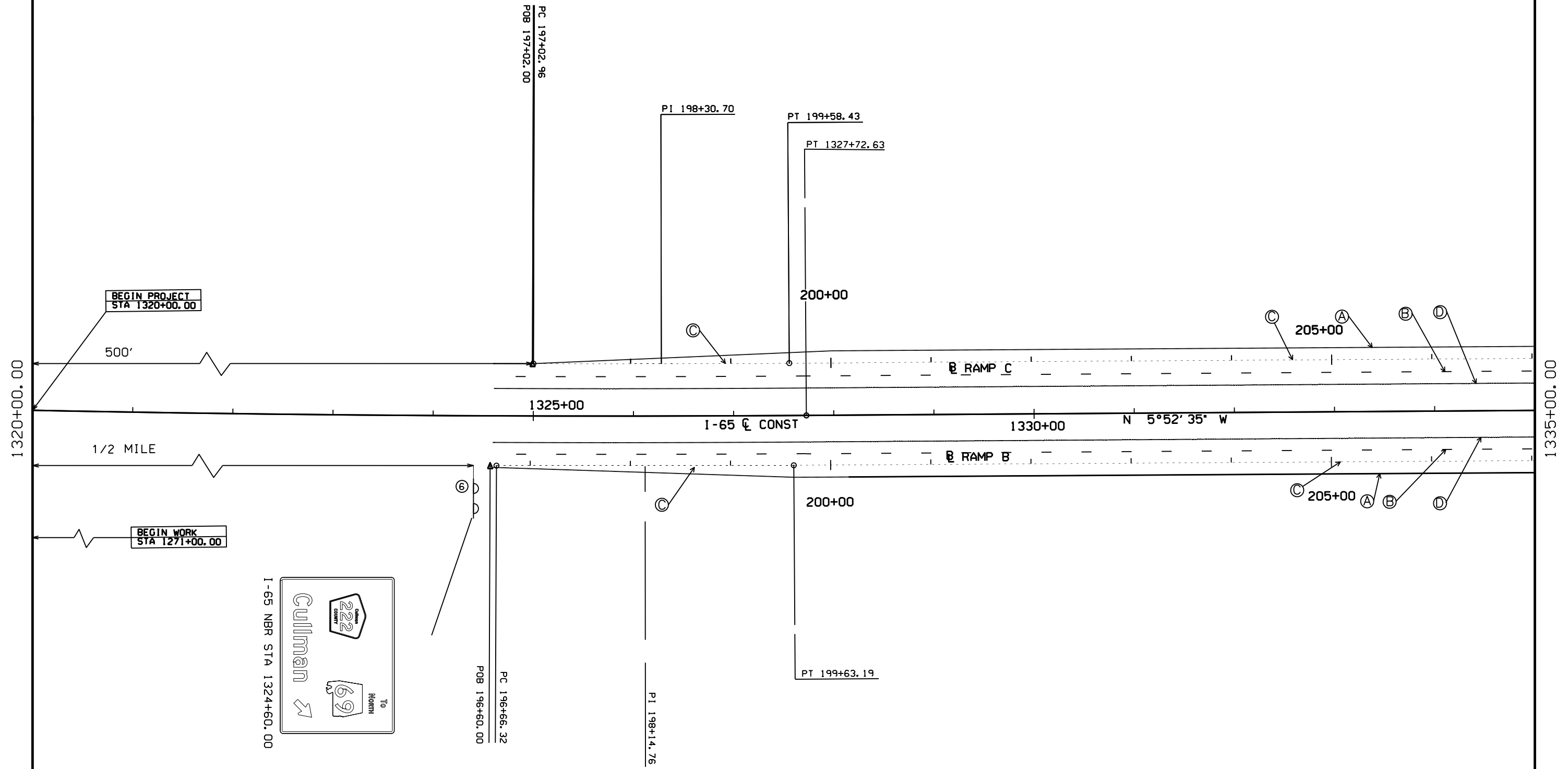

FIGURE 8A

RESPONSIBLE PE:	SUPERVISOR:	DESIGNER:	PLAN SUBMITTAL	ALABAMA DEPARTMENT OF TRANSPORTATION DESIGN BUREAU SECTION D3	50 0 50 HORIZ SCALE (FEET)	SHEET TITLE	ROUTE
DATE:	DATE:	DATE:	OE			SIGNING & STRIPING LAYOUT	22 I-65

SIGNING & STRIPING LAYOUT SHEET

REFERENCE PROJECT NO	FISCAL YEAR	SHEET NO
ACIM59761-ATRP(001)	2014	35-B

- (A) SOLID WHITE, CLASS 2, TYPE A TRAFFIC STRIPE (5" WIDE)
- (B) BROKEN WHITE, CLASS 2, TYPE A TRAFFIC STRIPE (5" WIDE)
- (C) DOTTED WHITE, CLASS 2, TYPE A TRAFFIC STRIPE (5" WIDE)
- (D) SOLID YELLOW, CLASS 2, TYPE A TRAFFIC STRIPE (5" WIDE)
- (E) TRAFFIC CONTROL MARKINGS, CLASS 2, TYPE A

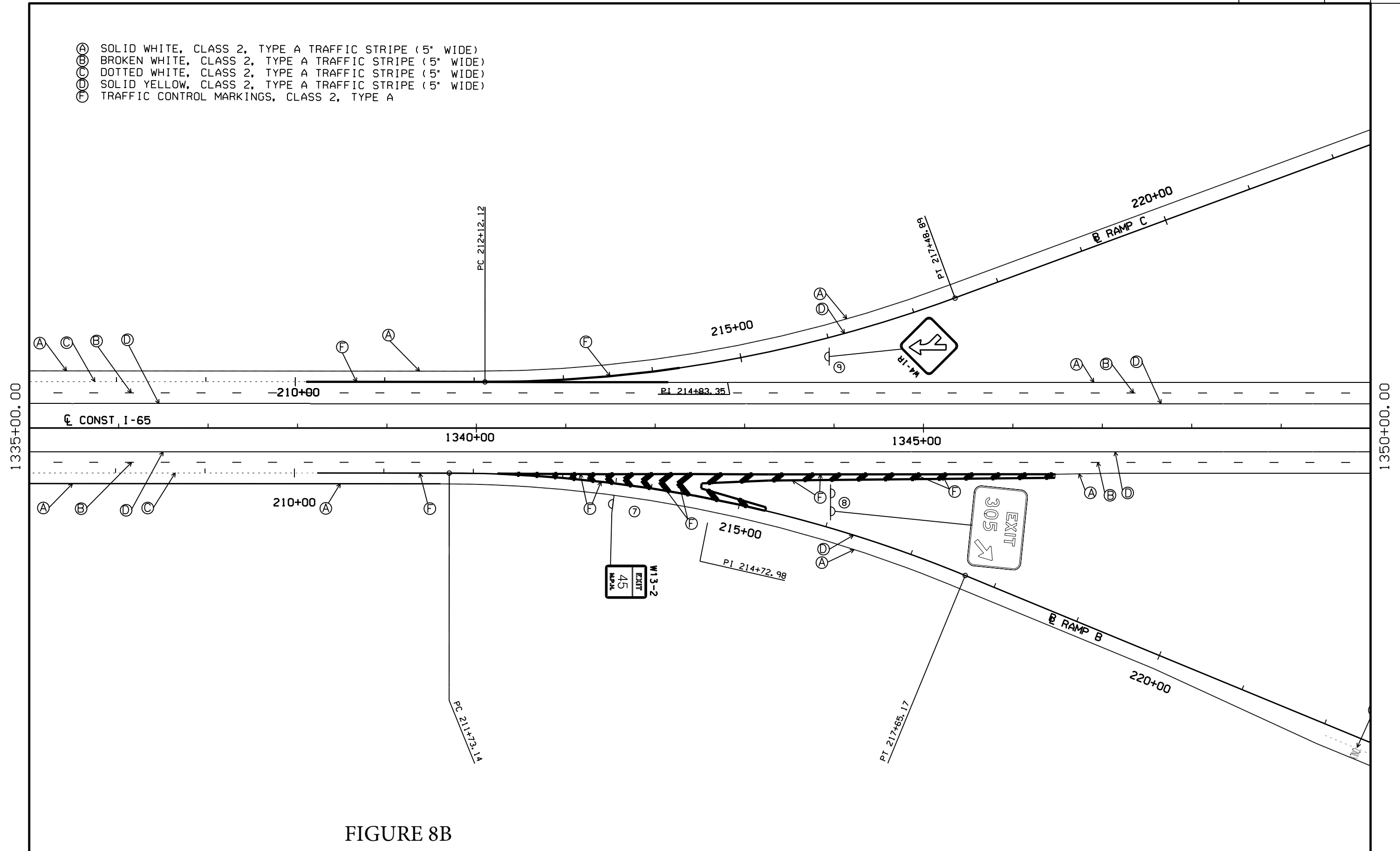
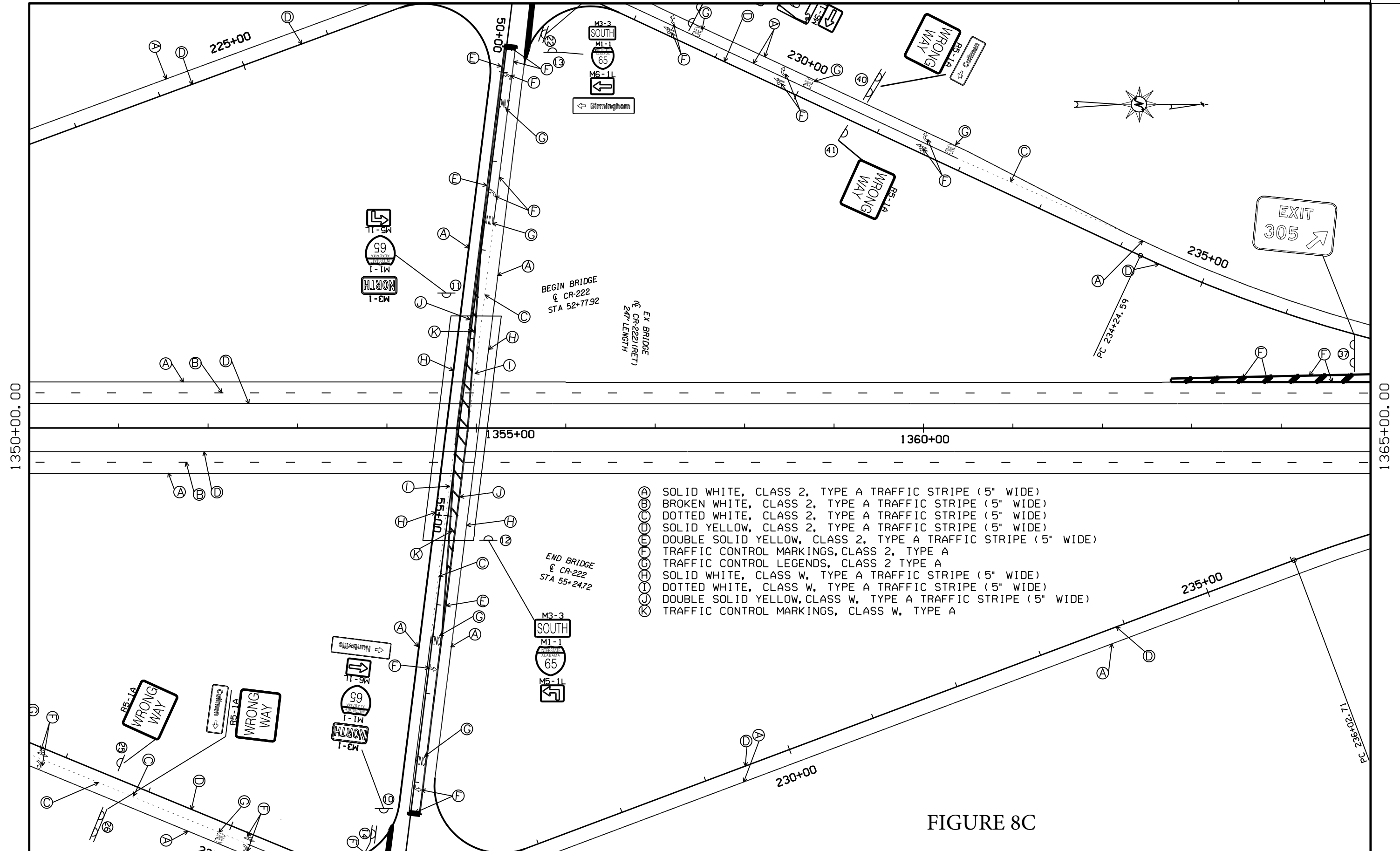

FIGURE 8B

RESPONSIBLE PE:	SUPERVISOR:	DESIGNER:	PLAN SUBMITTAL	ALABAMA DEPARTMENT OF TRANSPORTATION DESIGN BUREAU SECTION D3	50 0 50 HORIZ SCALE (FEET)	SHEET TITLE	ROUTE
DATE:	DATE:	DATE:	OE			SIGNING & STRIPING LAYOUT	28 I-65

SIGNING & STRIPING LAYOUT SHEET

REFERENCE PROJECT NO	FISCAL YEAR	SHEET NO
ACIM59761-ATRP(001)	2014	35C



- Ⓐ SOLID WHITE, CLASS 2, TYPE A TRAFFIC STRIPE (5" WIDE)
- Ⓑ BROKEN WHITE, CLASS 2, TYPE A TRAFFIC STRIPE (5" WIDE)
- Ⓒ DOTTED WHITE, CLASS 2, TYPE A TRAFFIC STRIPE (5" WIDE)
- Ⓓ SOLID YELLOW, CLASS 2, TYPE A TRAFFIC STRIPE (5" WIDE)
- Ⓔ DOUBLE SOLID YELLOW, CLASS 2, TYPE A TRAFFIC STRIPE (5" WIDE)
- Ⓕ TRAFFIC CONTROL MARKINGS, CLASS 2, TYPE A
- Ⓖ TRAFFIC CONTROL LEGENDS, CLASS 2 TYPE A
- Ⓗ SOLID WHITE, CLASS W, TYPE A TRAFFIC STRIPE (5" WIDE)
- Ⓙ DOTTED WHITE, CLASS W, TYPE A TRAFFIC STRIPE (5" WIDE)
- Ⓚ DOUBLE SOLID YELLOW, CLASS W, TYPE A TRAFFIC STRIPE (5" WIDE)
- Ⓛ TRAFFIC CONTROL MARKINGS, CLASS W, TYPE A

FIGURE 8C

RESPONSIBLE PE:	SUPERVISOR:	DESIGNER:	PLAN SUBMITTAL:	ALABAMA DEPARTMENT OF TRANSPORTATION DESIGN BUREAU SECTION D3	50 0 50 HORIZ SCALE (FEET)	SHEET TITLE	ROUTE
DATE:	DATE:	DATE:	OE			SIGNING & STRIPING LAYOUT	24 I-65

SIGN FACE DETAILS

SIGN FACE DETAILS

- Details will need to be provided in the plans for all sign panels which are not shown in the SHS drawings in the ALDOT Standard Drawing Book. These include all destination signs, ground mounted directional, advance guide, specific service signs, exit directional and all overhead mounted sign panels.
- A design file should be set up for the detail for each required sign face. These files should then be referenced to sign face detail sheets. Show the required color of the background, borders and legends for all required panels as well as any sign face detail notes on this sheet. See Figure 10.
- Show all dimensions on the sign face details including dimensions of the border width and radius. See Figure 9.
- Information for letter sizes and styles for Guide Signs for Freeways and Expressways can be found in Chapter 2E and Tables 2E-1 – 2E-5 of the current MUTCD Edition. Use the dimensions shown in the Intermediate column for all Interstate guide signs unless it is an Interstate to Interstate project. For these projects dimensions shown in the Major Category A column may be used. Clearview font is required by ALDOT for certain words (refer to the attached memo for more information).
- All exit configurations with an option lane must use the Arrow-Per-Lane sign design group except for when the interchange is classified as intermediate or minor (although ALDOT suggests using Arrow-Per-Lane at these locations as well), when the scope of the work is limited to maintenance replacement, or an approach partial replacement, when the use of Arrow-Per-Lane signs would otherwise not be practical for the given location or as built geometry, or where engineering study or judgment prescribes another sign design group to best serve the traveling public.
- For more information on Arrow-Per-Lane signs, see Section 2E.20-21 of the current MUTCD Edition. For further information as to what constitutes “new or reconstructed”, see FHWA Interpretation Letter 2(09)-5(I).
- If a conventional sign design is used for an option lane, the signing shall be as shown in Figure 2E-11 of the current MUTCD.
- See the additional sheets included in this section for additional information and examples for designing sign face details.

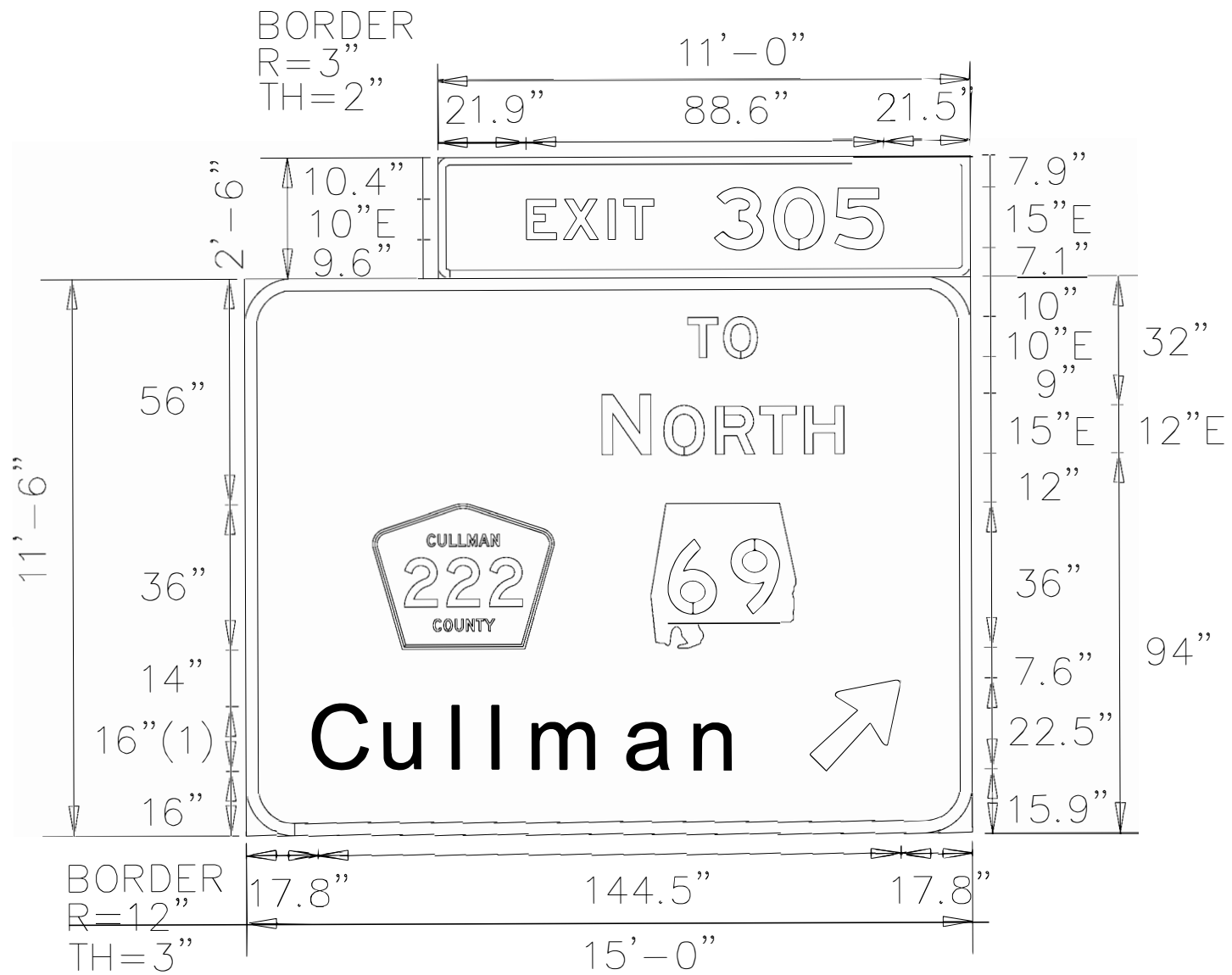

FONT:
(1) ClearviewHwy-5-W

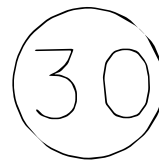
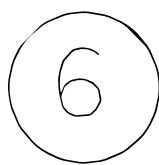
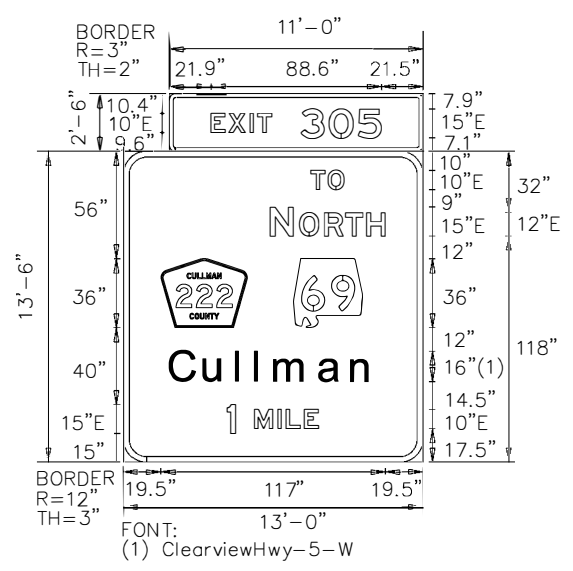

FIGURE 9

SPECIAL PROJECT DETAIL- SIGN FACE DETAILS

REFERENCE PROJECT NO	FISCAL YEAR	SHEET NO



① ③②

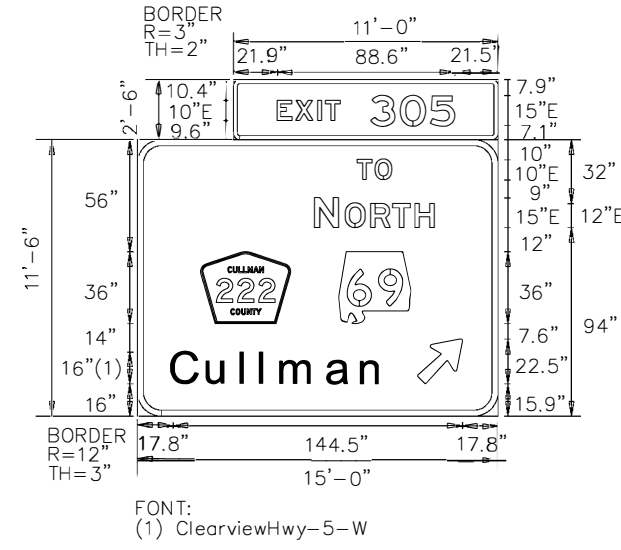

⑥ ③⑦

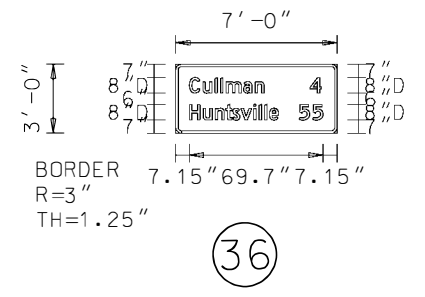

③⑥

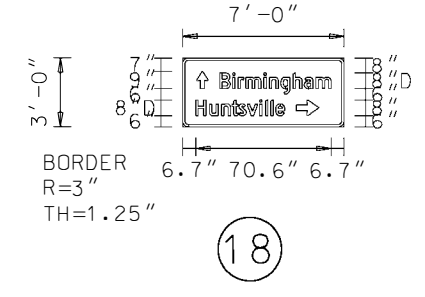

⑱

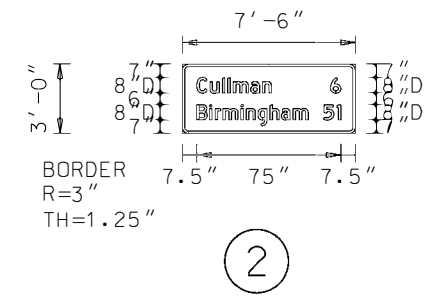

②

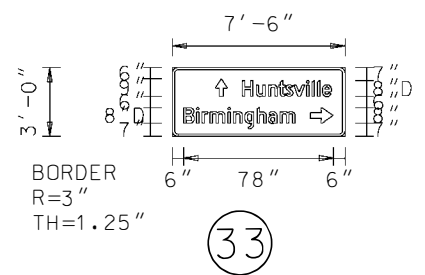

③③

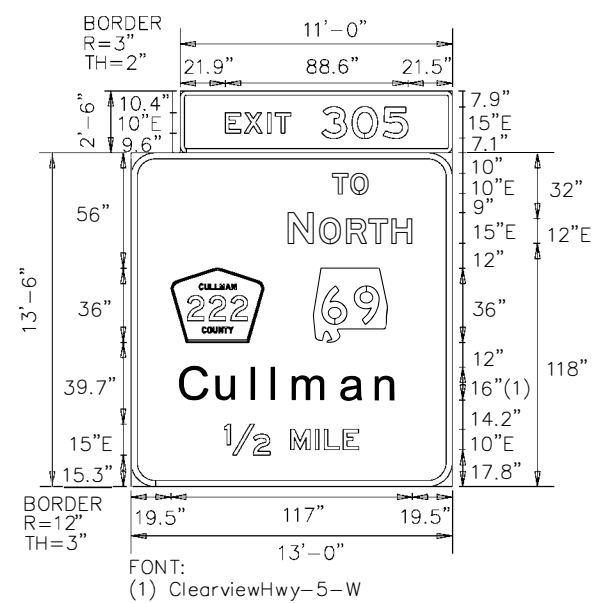

④ ③①

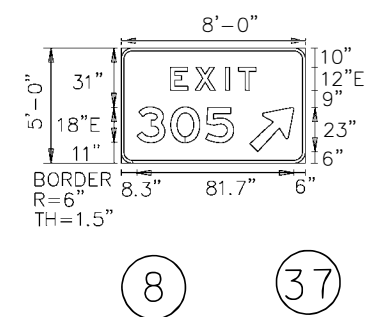

⑧ ③⑦

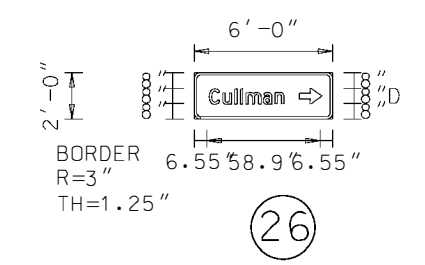

②⑥

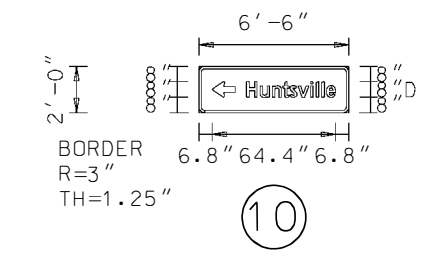

⑩

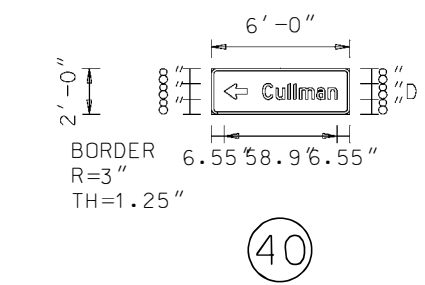

④⑦

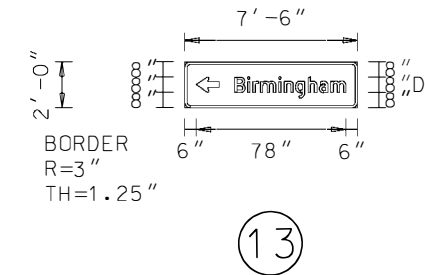

⑬

- NOTES**
1. All Class 6 sign panels shall have Type III or IV background and modified series E letters unless otherwise noted.
 2. All Class 6 signs shall have white letters and borders on a green background unless otherwise noted.
 3. For Class 6 signs, all letters, numerals, arrows, shields and borders shall have encapsulated lens reflectorization.
 4. For details and colors of State, U.S. and Interstate shields, see Special Drawing SHS-18.
 5. The exit number panels have a 2' border on the top and sides only and an 8' radius on the top only.

FIGURE 10

T:\D\NT006(RED)\td_dickers\TC\Signing Plan Design Guide\Working Manual\Sign Face Details\SIGN FACE DETAIL.DGN 8/28/2018 1:48:39 PM dickers

RESPONSIBLE PE:	SUPERVISOR:	DESIGNER:	PLAN SUBMITTAL	ALABAMA DEPARTMENT OF TRANSPORTATION	NOT TO SCALE	SHEET TITLE	ROUTE
DATE:	DATE:	DATE:				SPECIAL PROJECT DETAIL- 28 SIGN FACE DETAILS	I-65

Manual on Uniform Traffic Control Devices (MUTCD)

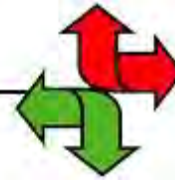

[resources](#) > [interpretations](#)

Interpretation Letter 2(09)-5(I) - Overhead Arrow-per-Lane Sign Requirements for Major Interchanges and Reconstructed Locations—Utah

[PDF Version](#), 103KB

You will need the [Adobe Acrobat Reader](#) to view the PDF on this page.



U.S. Department of Transportation
Federal Highway Administration

1200 New Jersey Avenue, SE.
Washington, D.C. 20590

October 22, 2010

In Reply Refer To: HOTO-1

John R. Njord, P.E.
Executive Director
Utah Department of Transportation
P.O. Box 141265
Salt Lake City, UT 84114

Dear Mr. Njord:

Thank you for the opportunity to engage in recent discussions regarding your July 6 letter to Administrator Mendez. Based on the issues raised in your letter and during the September 14 teleconference with representatives of the Utah Department of Transportation, we are issuing this Official Interpretation of the provisions of the 2009 Manual on Uniform Traffic Control Devices (MUTCD) related to the signing of freeway and expressway exits that have an option lane. Two specific issues discussed during the September 14 teleconference are addressed in this interpretation.

The first issue deals with what is meant by "reconstructed" in Section 2E.21, Paragraph 2, of the MUTCD. It is our Official Interpretation that the term "reconstructed" in this Section applies to those facilities where the replacement of the overhead sign support structures is made necessary as a result of the reconstruction, typically due to either widening or reconfiguration of the travel lanes. If the existing sign support structure is to remain, then the existing signing may remain or be replaced in kind provided that other provisions within the MUTCD are not violated.

The second issue deals with the definition of the term "major interchange" as it applies to the requirement to use Overhead Arrow-per-Lane signing at multi-lane exits that have an option lane. Section 2E.20 requires the use of either Overhead Arrow-per-Lane signs or Diagrammatic signs at major interchanges. A "major interchange" is defined in Section 2E.32 (and similarly in Section 1A.13) as:

- a. [I]nterchanges with other expressways or freeways, or (b) interchanges with high-volume multi-lane highways, principal urban arterials, or major rural routes where the volume of interchanging traffic is heavy or includes many road users unfamiliar with the area.

The definition of category (a) major interchanges is very clear and is not open to interpretation. Thus, Overhead Arrow-per-Lane guide signs are required for multi-lane exits with an option lane at these "system" interchanges if they are new or reconstructed. The determination of what constitutes a category (b) major interchange for purposes of the Overhead Arrow-per-Lane signing requirement is what is unclear and is the subject of this interpretation

There is an inherent level of flexibility in the category of "Major (b)" because specific criteria such as "high-volume," "heavy traffic," "principal," "many," and other terms used to define this category of the "major" classification are not quantified in the MUTCD. In particular, the term "principal urban arterial" is not defined in the MUTCD. In this context, "principal urban arterial" is not necessarily intended to apply categorically to all routes in a particular highway agency's system of functional classification that happens to use this nomenclature. In all cases, the determination of whether a particular interchange has characteristics that would classify it as major (b) or intermediate can be determined only through the application of engineering judgment.

Thus, it is our Official Interpretation that engineering judgment is to be used to determine whether a particular non-system interchange multi-lane exit with an option lane should be classified as a category (b) major interchange or as an intermediate interchange for the purposes of guide signing design and, in particular, for required application of Overhead Arrow-per-Lane guide signs. Overhead Arrow-per-Lane signs have been shown to provide significant benefits to unfamiliar drivers and, therefore, the highway agency should give careful consideration to this aspect in making its determinations for a given multi-lane exit with an option lane

It should also be noted that Paragraphs 2 and 3 of Section 2E.20 recommend consideration of the use of Overhead Arrow-per-Lane guide signs for multi-lane exits with an option lane at intermediate and minor interchanges. Interchanges of these classifications can also have unfamiliar users that will derive significant benefits from Overhead Arrow-per-Lane guide signs.

We appreciate the opportunity to clarify the intentions of the provisions of the MUTCD and trust that this interpretation will address your concerns. For recordkeeping purposes, we have assigned this interpretation the following Official Ruling number and title: "2(09)-5(1) - Overhead Arrow-per-Lane Sign Requirements for Major Interchanges and Reconstructed Locations—Utah." Please refer to this number and title in any future correspondence on this matter

Sincerely yours,

Original signed by:

Jeffrey A. Lindley
Associate Administrator for Operations



Table 2E-1. Freeway or Expressway Guide Sign and Plaque Sizes (Sheet 1 of 2)

Sign or Plaque	Sign Designation	Section	Minimum Size
Exit Number (plaque)			
1-, 2-Digit Exit Number	E1-5P	2E.31	114 x 30
3-Digit Exit Number	E1-5P	2E.31	132 x 30
1-, 2-Digit Exit Number (with single letter suffix)	E1-5P	2E.31	138 x 30
3-Digit Exit Number (with single letter suffix)	E1-5P	2E.31	156 x 30
1-, 2-Digit Exit Number (with dual letter suffix)	E1-5P	2E.31	168 x 30
3-Digit Exit Number (with dual letter suffix)	E1-5P	2E.31	186 x 30
Left (plaque)	E1-5aP	2E.33	72 x 30
Left Exit Number (plaque)			
1-, 2-Digit Exit Number	E1-5bP	2E.31	114 x 54
3-Digit Exit Number	E1-5bP	2E.31	132 x 54
1-, 2-Digit Exit Number (with single letter suffix)	E1-5bP	2E.31	138 x 54
3-Digit Exit Number (with single letter suffix)	E1-5bP	2E.31	156 x 54
1-, 2-Digit Exit Number (with dual letter suffix)	E1-5bP	2E.31	168 x 54
3-Digit Exit Number (with dual letter suffix)	E1-5bP	2E.31	186 x 54
Next Exit XX Miles (1 line)	—	2E.34	Varies x 24
Next Exit XX Miles (2 lines)	—	2E.34	Varies x 36
Exit Gore (no exit number)	E5-1	2E.37	72 x 60
Exit Gore (with exit number)			
1-, 2-Digit Exit Number	E5-1a	2E.37	78 x 60
3-Digit Exit Number	E5-1a	2E.37	96 x 60
1-Digit Exit Number (with single letter suffix)	E5-1a	2E.37	90 x 60
2-Digit Exit Number (with single letter suffix)	E5-1a	2E.37	108 x 60
3-Digit Exit Number (with single letter suffix)	E5-1a	2E.37	126 x 60
1-Digit Exit Number (with dual letter suffix)	E5-1a	2E.37	120 x 60
2-Digit Exit Number (with dual letter suffix)	E5-1a	2E.37	138 x 60
3-Digit Exit Number (with dual letter suffix)	E5-1a	2E.37	156 x 60
Exit Number (plaque)			
1-, 2-Digit Exit Number	E5-1bP	2E.37	42 x 30
3-Digit Exit Number	E5-1bP	2E.37	60 x 30
1-Digit Exit Number (with single letter suffix)	E5-1bP	2E.37	48 x 30
1-Digit Exit Number (with dual letter suffix)	E5-1bP	2E.37	72 x 30
2-Digit Exit Number (with single or dual letter suffix)	E5-1bP	2E.37	72 x 30
3-Digit Exit Number (with single or dual letter suffix)	E5-1bP	2E.37	72 x 30
Narrow Exit Gore	E5-1c	2E.37	60 x 90*
Pull-Through	E6-2	2E.12	Varies x 120*
Pull-Through	E6-2a	2E.12	Varies x 90*
Exit Only (with arrow)	E11-1,1d	2E.24	174** x 36
Exit	E11-1a	2E.24	66 x 18
Only	E11-1b	2E.24	66 x 18
Exit Only	E11-1c	2E.24	120 x 18
Exit Only (with two arrows)	E11-1e,1f	2E.24	222** x 36
Left	E11-2	2E.40	60 x 18
Exit Gore Advisory Speed (plaque)	E13-1P	2E.37	72 x 24
Exit Direction Advisory Speed	E13-2	2E.36	162 x 24
Interstate Route Sign (1 or 2 digits)	M1-1	2E.27	36 x 36
Interstate Route Sign (3 digits)	M1-1	2E.27	45 x 36
Off-Interstate Route Sign (1 or 2 digits)	M1-2,3	2E.27	36 x 36
Off-Interstate Route Sign (3 digits)	M1-2,3	2E.27	45 x 36
U.S. Route Sign (1 or 2 digits)	M1-4	2E.27	36 x 36
U.S. Route Sign (3 digits)	M1-4	2E.27	45 x 36
State Route Sign (1 or 2 digits)	M1-5	2D.11	36 x 36

Table 2E-1. Freeway or Expressway Guide Sign and Plaque Sizes (Sheet 2 of 2)

Sign or Plaque	Sign Designation	Section	Minimum Size
State Route Sign (3 digits)	M1-5	2D.11	45 x 36
County Route Sign (1, 2, or 3 digits)	M1-6	2D.11	36 x 36
Forest Route (1, 2, or 3 digits)	M1-7	2D.11	36 x 36
Eisenhower Interstate System	M1-10,10a	2E.28	36 x 36
Junction	M2-1	2D.13	30 x 21
Combination Junction (2 route signs)	M2-2	2D.14	60 x 48*
Cardinal Direction	M3-1,2,3,4	2D.15	36 x 18
Alternate	M4-1,1a	2D.17	36 x 18
By-Pass	M4-2	2D.18	36 x 18
Business	M4-3	2D.19	36 x 18
Truck	M4-4	2D.20	36 x 18
To	M4-5	2D.21	36 x 18
End	M4-6	2D.22	36 x 18
Temporary	M4-7,7a	2D.24	36 x 18
Begin	M4-14	2D.23	36 x 18
Advance Turn Arrow	M5-1,2,3	2D.26	30 x 21
Lane Designation	M5-4,5,6	2D.27	36 x 24
Directional Arrow	M6-1,2,2a,3,4,5,6,7	2D.28	30 x 21
Destination (1 line)	D1-1	2D.37	Varies x 30
Destination and Distance (1 line)	D1-1a	2D.37	Varies x 30
Destination (2 lines)	D1-2	2D.37	Varies x 54
Destination and Distance (2 lines)	D1-2a	2D.37	Varies x 54
Destination (3 lines)	D1-3	2D.37	Varies x 72
Destination and Distance (3 lines)	D1-3a	2D.37	Varies x 72
Distance (1 line)	D2-1	2D.41	Varies x 30
Distance (2 lines)	D2-2	2D.41	Varies x 54
Distance (3 lines)	D2-3	2D.41	Varies x 72
Street Name	D3-1,1a	2D.43	Varies x 18
Advance Street Name (2 lines)	D3-2	2D.44	Varies x 42*
Advance Street Name (3 lines)	D3-2	2D.44	Varies x 66*
Advance Street Name (4 lines)	D3-2	2D.44	Varies x 84*
Park - Ride	D4-2	2D.48	36 x 48
National Scenic Byways	D6-4	2D.55	24 x 24
National Scenic Byways	D6-4a	2D.55	24 x 12
Weigh Station XX Miles	D8-1	2E.54	96 x 72 (F) 78 x 60 (E)
Weigh Station Next Right	D8-2	2E.54	108 x 90 (F) 84 x 72 (E)
Weigh Station (with arrow)	D8-3	2E.54	84 x 78 (F) 66 x 60 (E)
Crossover	D13-1,2	2D.54	78 x 42
Freeway Entrance	D13-3	2D.46	48 x 30
Freeway Entrance (with arrow)	D13-3a	2D.46	48 x 42
Combination Lane Use / Destination	D15-1	2D.33	Varies x 96
Next Truck Lane XX Miles	D17-1	2D.51	60 x 66
Truck Lane XX Miles	D17-2	2D.51	60 x 54
Slow Vehicle Turn-Out XX Miles	D17-7	2D.52	96 x 54

* The size shown is for a typical sign as illustrated in the figures in Chapters 2D and 2E. The size should be determined based on the amount of legend required for the sign.

** The width shown represents the minimum dimension. The width shall be increased as appropriate to match the width of the guide sign.

- Notes: 1. Larger signs may be used when appropriate
2. Dimensions in inches are shown as width x height
3. Where two sizes are shown, the larger size is for freeways (F) and the smaller size is for expressways (E)

Table 2E-2. Minimum Letter and Numeral Sizes for Expressway Guide Signs According to Interchange Classification

Type of Sign	Type of Interchange (see Section 2E.32)				Overhead
	Major		Intermediate	Minor	
	Category a	Category b			
A. Advance Guide, Exit Direction, and Overhead Guide Signs					
Exit Number Plaques					
Words	10	10	10	8	10
Numerals & Letters	15	15	15	12	15
Interstate Route Signs					
Numerals	18	—	—	—	18
1- or 2-Digit Shields	36 x 36	—	—	—	36 x 36
3-Digit Shields	45 x 36	—	—	—	45 x 36
U.S. or State Route Signs					
Numerals	18	18	18	12	18
1- or 2-Digit Shields	36 x 36	36 x 36	36 x 36	24 x 24	36 x 36
3-Digit Shields	45 x 36	45 x 36	45 x 36	30 x 24	45 x 36
U.S. or State Route Text Identification (Example: US 56)					
Numerals & Letters	18	15	15	12	15
Cardinal Directions					
First Letters	18	15	12	10	15
Rest of Words	15	12	10	8	12
Auxiliary and Alternative Route Legends (Examples: JCT, TO, ALT, BUSINESS)					
Words	15	12	10	8	12
Names of Destinations					
Upper-Case Letters	20	16	13.33	10.67	16
Lower-Case Letters	15	12	10	8	12
Distance Numbers	18	15	12	10	15
Distance Fraction Numerals	12	10	10	8	10
Distance Words	12	10	10	8	10
Action Message Words	10	10	10	8	10
B. Gore Signs					
Words	10	10	10	8	—
Numerals & Letters	12	12	12	10	—

Note: Sizes are shown in inches and where applicable are shown as width x height

Table 2E-3. Minimum Letter and Numeral Sizes for Expressway Guide Signs According to Sign Type

Type of Sign	Minimum Size
A. Pull-Through Signs	
Destinations — Upper-Case Letters	13.33
Destinations — Lower-Case Letters	10
Route Signs	
1- or 2-Digit Shields	36 x 36
3-Digit Shields	45 x 36
Cardinal Directions — First Letters	12
Cardinal Directions — Rest of Word	10
B. Supplemental Guide Signs	
Exit Number — Words	8
Exit Number — Numerals and Letters	12
Place Names — Upper-Case Letters	10.67
Place Names — Lower-Case Letters	8
Action Messages	8
Route Signs	
Numerals	12
1- or 2-Digit Shield	24 x 24
3-Digit Shield	30 x 24
C. Interchange Sequence or Community Interchanges Identification Signs	
Words — Upper-Case Letters	10.67
Words — Lower-Case Letters	8
Numerals	10.67
Fraction Numerals	8
Route Signs	
Numerals	12
1- or 2-Digit Shield	24 x 24
3-Digit Shield	30 x 24
D. Next XX Exits Sign	
Place Names — Upper-Case Letters	10.67
Place Names — Lower-Case Letters	8
NEXT XX EXITS — Words	8
NEXT XX EXITS — Number	12

Type of Sign	Minimum Size
E. Distance Signs	
Words — Upper-Case Letters	8
Words — Lower-Case Letters	6
Numerals	8
Route Signs	
Numerals	9
1- or 2-Digit Shield	18 x 18
3-Digit Shield	22.5 x 18
F. General Services Signs (see Chapter 2I)	
Exit Number — Words	8
Exit Number — Numerals and Letters	12
Services	8
G. Rest Area, Scenic Area, and Roadside Area Signs (see Chapter 2I)	
Words	10
Distance Numerals	12
Distance Fraction Numerals	8
Distance Words	8
Action Message Words	10
H. Reference Location Signs (see Chapter 2H)	
Words	4
Numerals	10
I. Boundary and Orientation Signs (see Chapter 2H)	
Words — Upper-Case Letters	8
Words — Lower-Case Letters	6
J. Next Exit and Next Services Signs	
Words and Numerals	8
K. Exit Only Signs	
Words	12
L. Overhead Arrow-Per-Lane and Diagrammatic Signs	
See Table 2E-5	

Note: Sizes are shown in inches and where applicable are shown as width x height

Table 2E-4. Minimum Letter and Numeral Sizes for Freeway Guide Signs According to Interchange Classification

Type of Sign	Type of Interchange (see Section 2E.32)				Overhead
	Major		Intermediate	Minor	
	Category a	Category b			
A. Advance Guide, Exit Direction, and Overhead Guide Signs					
Exit Number Plaques					
Words	10	10	10	10	10
Numerals & Letters	15	15	15	15	15
Interstate Route Signs					
Numerals	24/18	—	—	—	18
1- or 2-Digit Shields	48 x 48/ 36 x 36	—	—	—	36 x 36
3-Digit Shields	60 x 48/ 45 x 36	—	—	—	45 x 36
U.S. or State Route Signs					
Numerals	24/18	18	18	12	18
1- or 2-Digit Shields	48 x 48/ 36 x 36	36 x 36	36 x 36	24 x 24	36 x 36
3-Digit Shields	60 x 48/ 45 x 36	45 x 36	45 x 36	30 x 24	45 x 36
U.S. or State Route Text Identification (Example: US 56)					
Numerals & Letters	18	18/15	15	12	15
Cardinal Directions					
First Letters	18	15	15	10	15
Rest of Words	15	12	12	8	12
Auxiliary and Alternative Route Legends (Examples: JCT, TO, ALT, BUSINESS)					
Words	15	12	12	8	12
Names of Destinations					
Upper-Case Letters	20	20	16	13.33	16
Lower-Case Letters	15	15	12	10	12
Distance Numbers	18	18/15	15	12	15
Distance Fraction Numerals	12	12/10	10	8	10
Distance Words	12	12/10	10	8	10
Action Message Words	12	12/10	10	8	10
B. Gore Signs					
Words	12	12	12	8	—
Numeral & Letters	18	18	18	12	—

Notes: 1. Sizes are shown in inches and where applicable are shown as width x height
 2. Slanted line (/) signifies separation of desirable and minimum sizes

Table 2E-5. Minimum Letter and Numeral Sizes for Freeway Guide Signs According to Sign Type

Type of Sign	Minimum Size
A. Pull-Through Signs	
Destinations — Upper-Case Letters	16
Destinations — Lower-Case Letters	12
Route Signs	
1- or 2-Digit Shields	36 x 36
3-Digit Shields	45 x 36
Cardinal Directions — First Letter	15
Cardinal Directions — Rest of Word	12
B. Supplemental Guide Signs	
Exit Number Words	10
Exit Number Numerals and Letters	15
Place Names — Upper-Case Letters	13.33
Place Names — Lower-Case Letters	10
Action Messages	8
Route Signs	
Numerals	12
1- or 2-Digit Shield	24 x 24
3-Digit Shield	30 x 24
C. Interchange Sequence or Community Interchanges Identification Signs	
Words — Upper-Case Letters	13.33
Words — Lower-Case Letters	10
Numerals	13.33
Fraction Numerals	10
Route Signs	
Numerals	12
1- or 2-Digit Shield	24 x 24
3-Digit Shield	30 x 24
D. Next XX Exits Sign	
Place Names — Upper-Case Letters	13.33
Place Names — Lower-Case Letters	10
NEXT XX EXITS — Words	10
NEXT XX EXITS — Number	15
E. Distance Signs	
Words — Upper-Case Letters	8
Words — Lower-Case Letters	6
Numerals	8
Route Signs	
Numerals	9
1- or 2-Digit Shield	18 x 18
3-Digit Shield	22.5 x 18
F. General Services Signs (see Chapter 2I)	
Exit Number Words	10
Exit Number Numerals and Letters	15
Services	10

Type of Sign	Minimum Size
G. Rest Area, Scenic Area, and Roadside Area Signs (see Chapter 2I)	
Words	12
Distance Numerals	15
Distance Fraction Numerals	10
Distance Words	10
Action Message Words	12
H. Reference Location Signs (see Chapter 2H)	
Words	4
Numerals	10
I. Boundary and Orientation Signs (see Chapter 2H)	
Words — Upper-Case Letters	8
Words — Lower-Case Letters	6
J. Next Exit and Next Services Signs	
Words and Numerals	8
K. Exit Only Signs	
Words	12
L. Overhead Arrow-Per-Lane Signs	
Arrowhead (Type D Directional Arrow)	21.625
Arrow Shaft Width	8
Arrow Height	
Through	72
Left Only	48
Right Only	48
Optional-Diverge (Through with Left or Right)	72
Optional-Split (Left and Right)	66
Vertical Separator Width	2
Vertical Space between Vertical Separator and Top of Nearest Arrow	8
Horizontal Space between Vertical Separator and Top of Nearest Through Arrow	15
Horizontal Space between Arrow Shaft and EXIT and ONLY plaques	10
EXIT and ONLY Panels	60 x 18
M. Diagrammatic Signs	
Arrowhead (Type D Directional Arrow)	13.5*
Lane Widths	5
Lane Line Segments	1 x 6
Spacing between Lane Line Segments	6
Stem Height to Upper Point of Departure	30
Horizontal Space between Arrowhead and Route Shield or Destination	12

* The size shown is the arrowhead width per lane depicted on the corresponding arrow shaft

Note: Sizes are shown in inches and where applicable are shown as width x height



ALABAMA DEPARTMENT OF TRANSPORTATION

Design Bureau

1409 Coliseum Boulevard, Montgomery, Alabama 36110

P. O. Box 303050, Montgomery, Alabama 36130-3050

Phone: 334-242-6178 FAX: 334-269-0826



Kay Ivey
Governor

John R. Cooper
Transportation Director

July 10, 2018

MEMORANDUM

TO: Region Engineers
Area Engineers
Region Pre-Construction Engineers
Area Pre-Construction Engineers

FROM: Steven E. Walker, P.E. *S.E. Walker*
State Design Engineer

RE: Clearview Highway Font for Guide Signs

FHWA has reinstated Interim Approval IA-5 for the optional use of Clearview Font for Positive Contrast Legends on Guide Signs. ALDOT has requested and received approval from FHWA to utilize IA-5. In accordance with FHWA's Interim Approval and associated guidance, Clearview should only be used for Mixed-Case (one upper-case letter followed by subsequent lower-case letters) destination legends on positive contrast guide signs.

Effective immediately, Clearview Font should be used in place of Mixed-Case E-Modified (EM) font on guide signs. Please see Figure 1 (attached) and the following for additional guidance on the use of Clearview Font:

When to Use Clearview Lettering

Clearview lettering 5-W should be used instead of FHWA Standard Highway Alphabet series E-Modified lettering for the mixed-case portion of guide signs and destination signs. This includes ground-mounted or overhead guide signs, post-mounted street name signs, and overhead street name signs at traffic signals.

When Not To Use Clearview Lettering

Clearview lettering shall not be used under any of the following circumstances:

- Regulatory or warning signs.
- ALL UPPER-CASE lettering on guide signs. Examples include: NEXT RIGHT, MILE, EAST, or an EXIT number.

When Not to Use Clearview Lettering (continued)

- Legends that are required to be ALL UPPER-CASE in the MUTCD (e.g. cardinal directions, distance messages, legends on standard regulatory and warning signs) shall not be converted to Mixed-Case lettering.
- Negative-contrast signs or sign elements (black lettering on white or colored background).
- Numerals or fractions, except when a part of a destination name (e.g. "91st Ave").
- Overlay panels if other destinations on the same sign are in Standard Alphabet series lettering.

Clearview lettering 1-W, 2-W, 3-W, and 4-W should not be used without prior approval, as research has not shown a benefit as compared to their Standard Alphabet equivalents.

See the example in Figure 1 for further clarification on when to use Clearview lettering versus Standard Alphabet series lettering.

Effects of Clearview on Sign Width

The proper use of Clearview 5-W lettering for mixed-case destination legends may cause the overall sign width to be greater than if the same sign were designed with Standard Alphabet series E-Modified. Clearview 5-W font should be used for such mixed-case destination legends unless that resulting wider sign will result in significant cost/engineering impacts. Examples include:

- When placing a new sign on an existing sign structure, if a narrower sign is necessary to avoid exceeding the structural capacity of the structure, or
- When placing an overlay panel on an existing sign, if a narrower overlay panel is necessary to fit on the existing sign, or
- If the use of a wider sign panel would require a cantilever sign structure longer than the maximum span length allowed.

If the resulting sign width with Clearview lettering must be reduced because of significant cost/engineering impacts, the following steps should be considered:

- 1) Use Clearview 5-W-R font in lieu of Clearview 5-W font. 5-W-R is similar to Clearview 5-W, but with reduced spacing between letters (kerning) to reduce overall width.
- 2) If Clearview 5-W-R font will still result in a sign width that results in significant cost/engineering impacts, then Standard Alphabet Series E-Modified font should be used.

If you have any questions or require additional information, please contact Gary Moore at (334)242-6160.

SEW/gwm
Attachment

- c: Stacey Glass, P.E. – State Maintenance Engineer
Terry McDuffie, P.E. – Quality Control Bureau Chief
Skip Powe, P.E. – State Construction Engineer
Terry Robinson – Innovative Programs Bureau Chief, Acting
Roadway Design Section
Traffic Design Section
Design/File

Figure 1 – Sample Sign Panel Layout

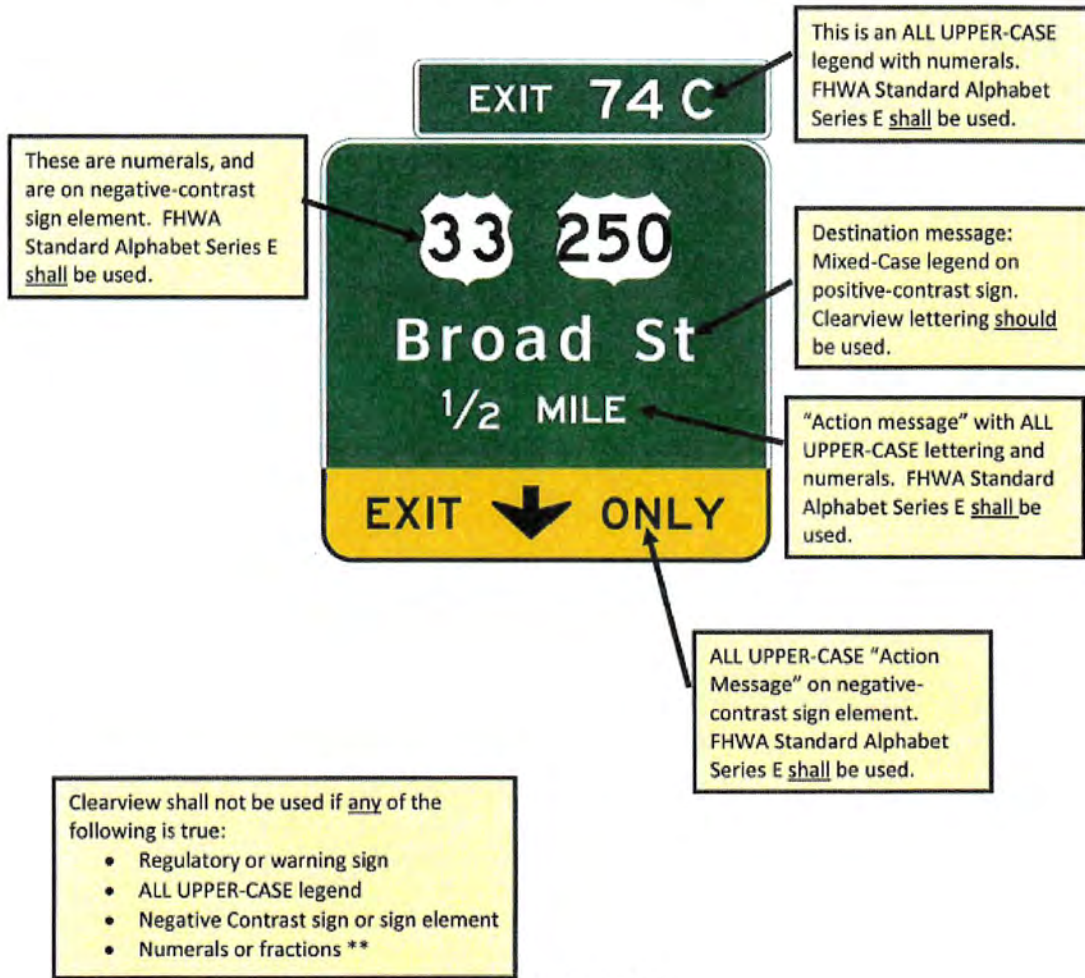

***except when the numerals are a part of a destination name, e.g. "91st Ave"*

ADDITIONAL INFORMATION FOR PANEL DESIGNS

- Spacing between a word and arrow or shields should be equal to the capitol letter height.
- Interline spacing should be equal to $\frac{3}{4}$ of the height of the upper case letters in the adjacent lines of letters.
- All lines of copy and shields should be centered on the sign panel.
- Spacing to the top and bottom edge borders should equal the average height of letters in the adjacent lines of copy. This should be adjusted slightly + or – as necessary for sizing the sign panel to 6” increments.
- Spacing to the vertical borders should equal the average height of the largest letter. This should also be adjusted slightly + or – as necessary for sizing the sign panel to 6” increments.
- Spacing between words in a line should be 1 $\frac{1}{2}$ times the letter height of the preceding letter.
- See Figure 11 for details of arrow sizes to be used on destination signs.
- See Figure 12 for details regarding the alignment of text on destination signs.
- The border thickness for sign panels should be as follows:
 - a. For sign panels 0 – 60 square foot – 1.125”
 - b. For sign panels 60 – 100 square foot – 2”
 - c. For sign panels over 100 square foot – 3”
- The radius sizes for sign panels should be as follows:
 - a. For sign panels with 0’ – 3’ height – 3”
 - b. For sign panels with 3.5’ – 5’ height – 6”
 - c. For sign panels with 5.5’ – 7’ height – 9”
 - d. For sign panels over 7.5’ height – 12”

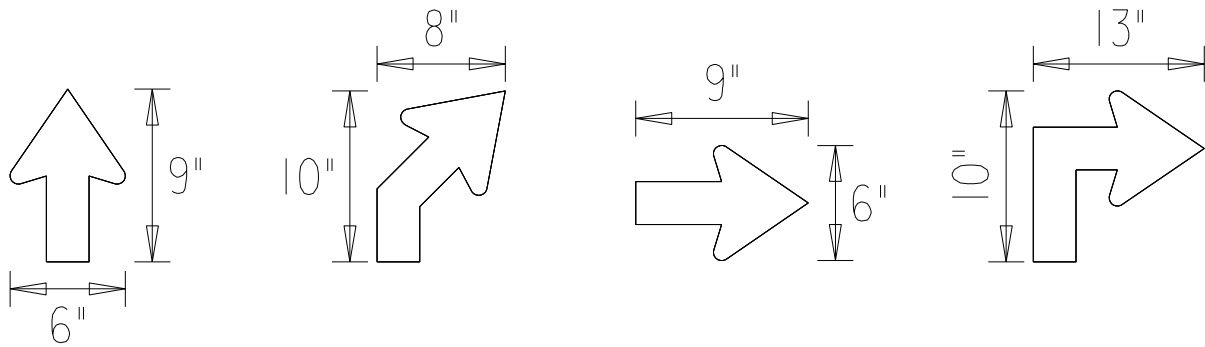

FIGURE 11

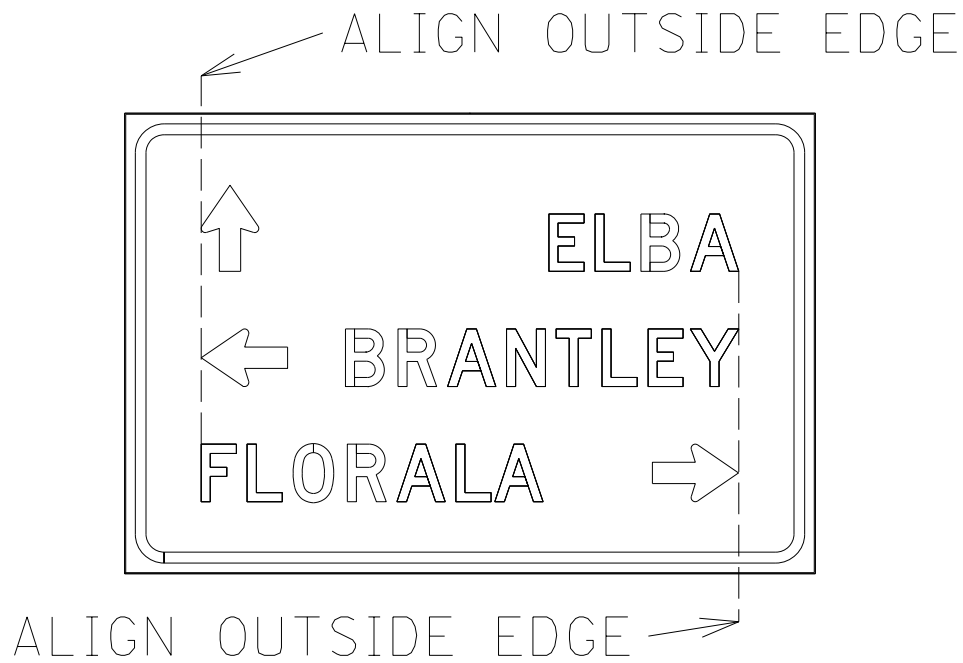

FIGURE 12

EXIT ONLY PANELS

- The exit only panel and the main panel should be the same width. If the main panel is narrower than the minimum width of the exit only panel, increase the width of the main panel to match the exit only panel. If the main panel is wider than the minimum width of the exit only panel, increase the width of the exit only panel to match the main panel.
- The exit only panel shall have a yellow background with black legends and borders.
- The width of the border of the exit only panel shall be the same as the width of the border of the main panel.
- The exit only panel shall have the same diameter radius as the main panel on the bottom only.
- The exit only panel shall only have borders along the sides and bottom.
- For Arrow-Per-Lane signs, the arrow for a lane that must exit shall be curved in the direction of the exit and shall be accompanied by black-on-yellow EXIT (E11-1a) and ONLY (E11-1b) sign panels adjacent to the lower end of the arrow shaft. The E11-1a and E11-1b sign panels shall not be used for a split of two overlapping routes where neither of the diverging routes is designated as an exit. Where the through lanes curve and the exit continues on a straight alignment, upward-pointing vertical arrows shall be used for the exiting movement and curved arrows for the through movement.
- The arrow for an optional exit lane that also carries the through route shall have a single shaft that bifurcates into a vertically upward-pointing arrow and a curving arrow corresponding to the configuration of the through and exit lanes.
- For examples of exit direction and exit only panels for Arrow-Per-Lane signs, see the attached Figures 2E-4, 2E-5, and 2E-6 from the MUTCD.

Figure 2E-4. Overhead Arrow-per-Lane Guide Signs for a Two-Lane Exit to the Right with an Option Lane

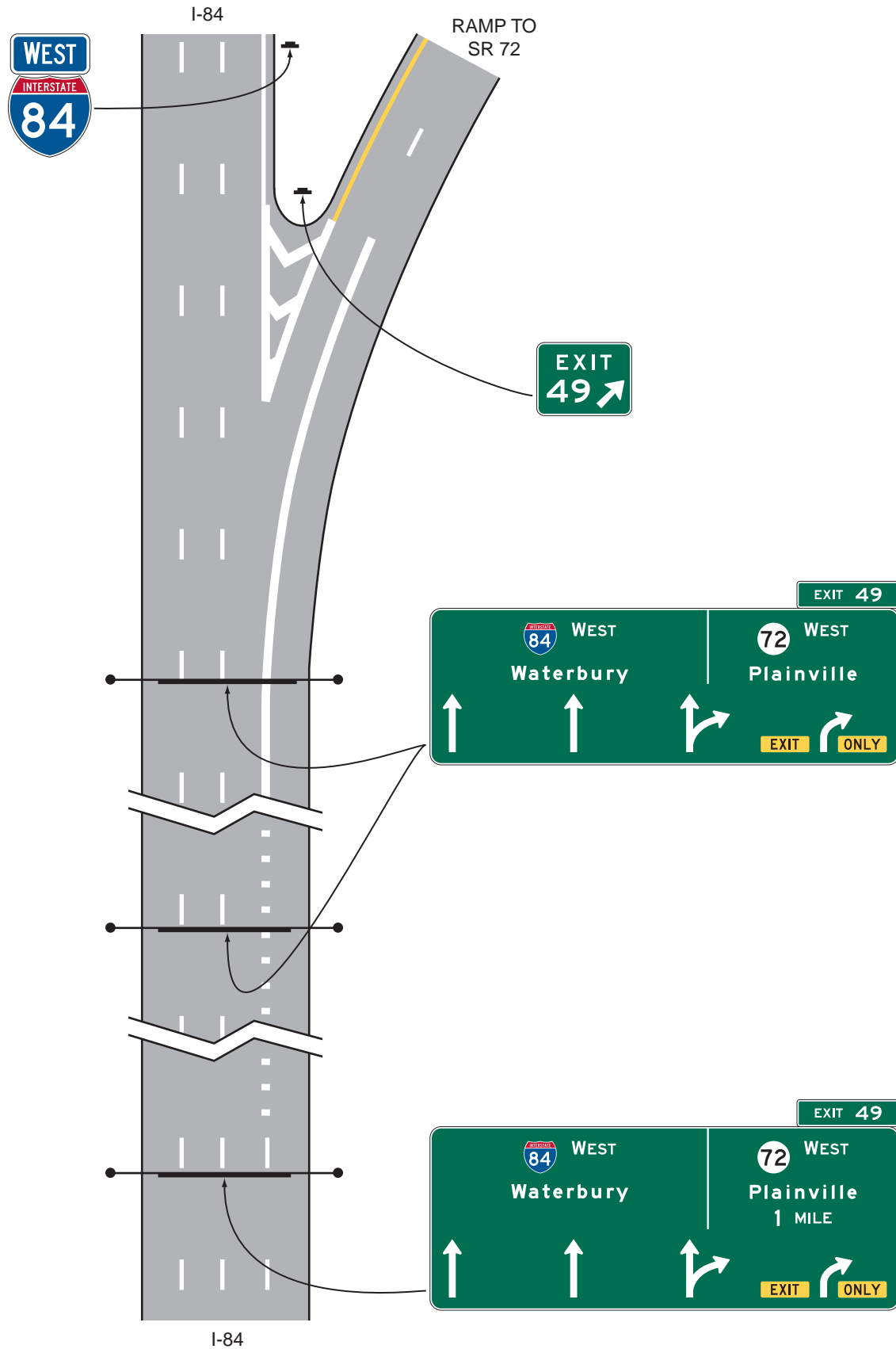

Figure 2E-5. Overhead Arrow-per-Lane Guide Signs for a Two-Lane Exit to the Right with an Option Lane (Through Lanes Curve to the Left)

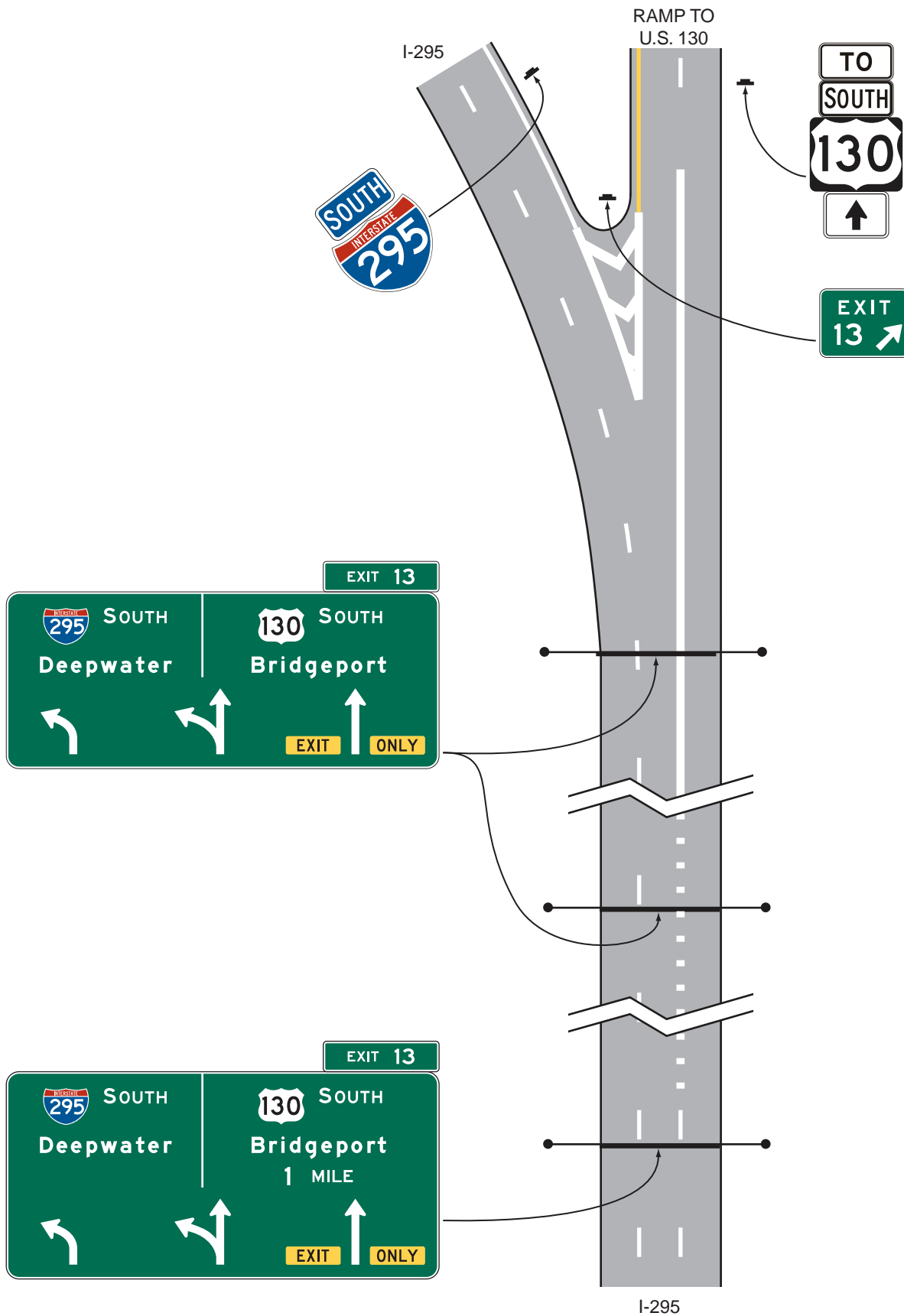
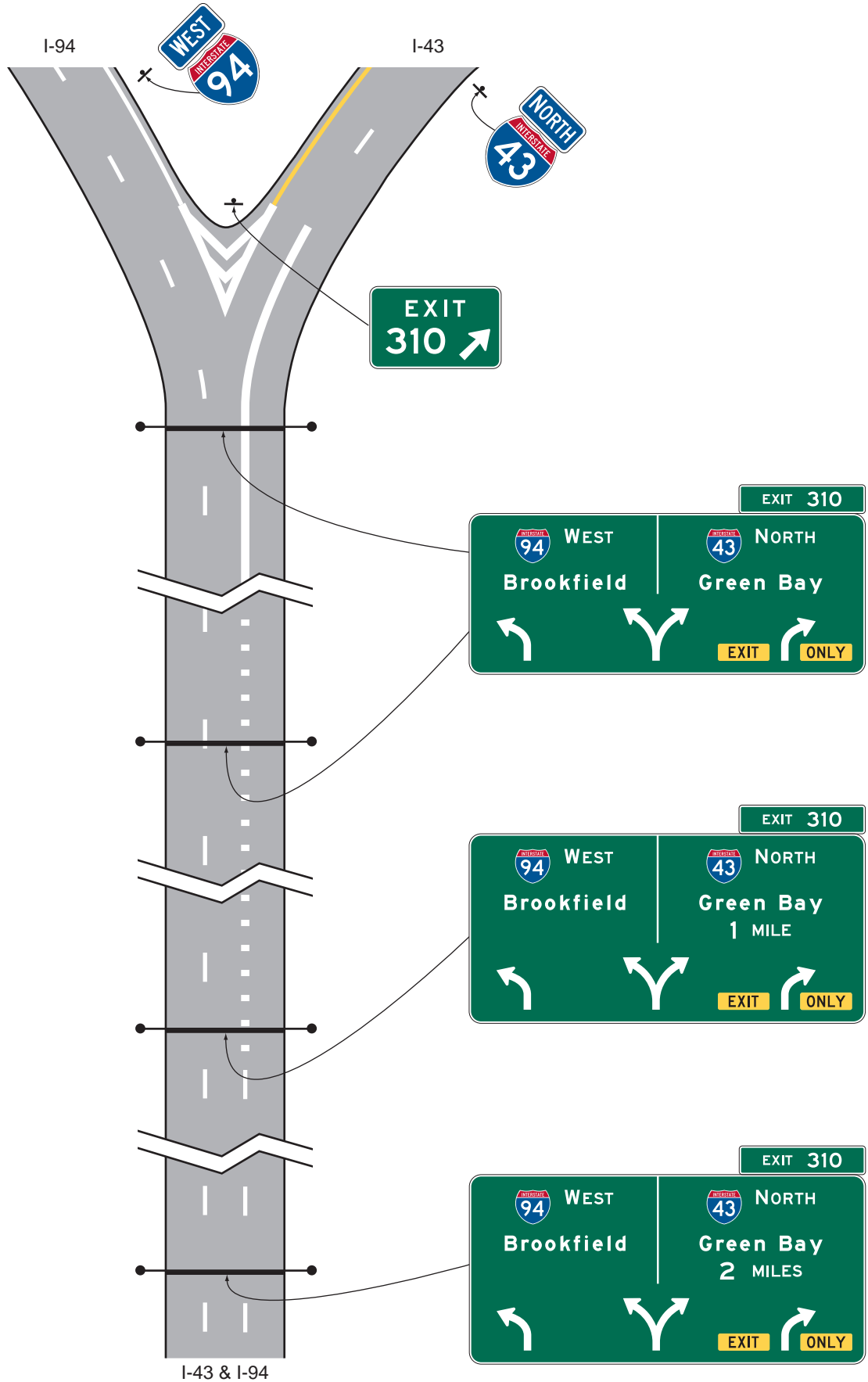

Figure 2E-6. Overhead Arrow-per-Lane Guide Signs for a Split with an Option Lane



MAIN PANELS

- The size of all M1-1, M1-4a and M1-4a shields when required on overhead sign installations shall have a height of 36" as shown in Tables 2E-1 – 2E-5 of the current MUTCD Edition. Details of the shields are shown on drawing SHS-19.
- On overhead sign installations that have main panels with exit only panels, the main panel shall have a border on the top and sides only and radius on the top only.

EXIT NUMBER PANELS

- The exit number panel shall have a 2" width border.
- The exit number panel shall have a 3" radius.
- The dimension of the exit only panel shall be a variable width and a 2.5' height. The exit number shall be 15" E lettering and the word "Exit" 10" E lettering.

SPECIFIC SERVICE SIGNS

- For information on specific service signs, see section 2J in the current edition of the MUTCD.
- See Figure 13 for an example of a sign face detail for a logo sign on the main line, a logo sign on an exit ramp, and typical sizes for the signs.

MAIN LINE

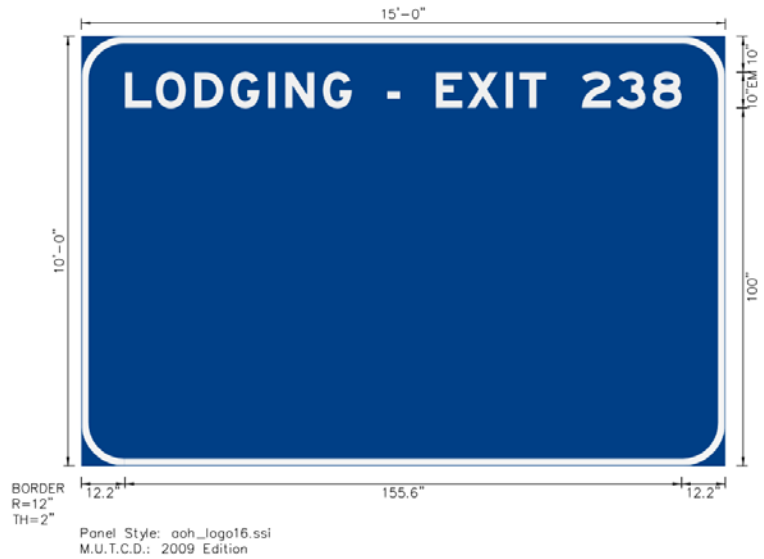

EXIT RAMP

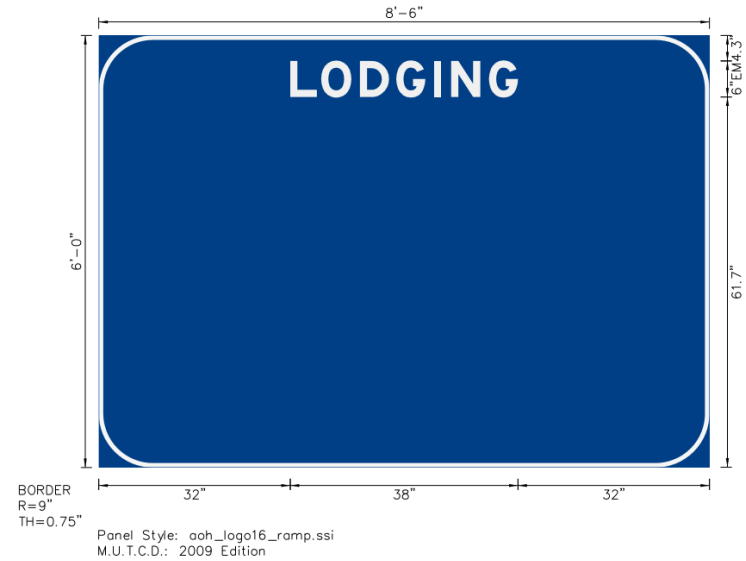

Specific Service Sign Size Templates

Location	Service(s)	Slots	Size (H X W)
Main Line	1	6	15' X 10'
Main Line	1	4	13' X 10'
Main Line	1	3	15' X 6'
Main Line	1	2	13' X 6'
Main Line	2	6	15' X 12'
Main Line	2	4	13' X 12'
Exit Ramp	1	6	8.5' X 6'
Exit Ramp	1	4	7' X 6'
Exit Ramp	1	3	8.5' X 3.5'
Exit Ramp	1	2	7.5' X 3.5'
Exit Ramp	2	6	8.5' X 7'
Exit Ramp	2	4	7' X 7'

FIGURE 13

2004 EDITION

English Version

Standard Highway Signs

Including Pavement Markings
and Standard Alphabets



For use with the
2003 MUTCD

U.S. Department of Transportation
**Federal Highway
Administration**

DESIGN GUIDELINES

There are general guidelines to follow in the design of highway signs in order to conform to basic standards. Many of these guidelines are mentioned in various sections of the Manual on Uniform Traffic Control Devices (MUTCD), while others are derived from accepted practice in sign design and layout. Highway signs with standardized designs conforming to the general guidelines (like most regulatory, warning, emergency management, school, railroad-highway grade crossing, and bicycle signs), are contained in this book and are shown with different standard sizes depending on the type of highway or facility where the sign is intended to be used.

Although some guide signs also have been standardized and are included in this book, most guide signs need to be designed separately because of the variability in message or legend. For most guide signs, there can be no rigid standardized sizes.

SIGN DIMENSION

Message variability controls overall sign dimensions. Whenever practicable, the overall dimensions of the sign plates should be in multiples of 6 inches (150 mm).

The use of a smaller than “nominal” size for the various four types of roadway sign may sometimes be justified. For instance, a sign mounted over a particular roadway lane to which it applies may have to be limited in width to the lane width. In some cases, vertical clearances may limit the vertical dimension of the sign. On the other hand, a larger than “nominal” sign may be desirable where greater legibility or emphases is needed. When a variation in the “standard” size is necessary, a reduced or enlarged (as the case may be) letter height, interline, and edge spacing may be used but should be as nearly comparable to standards as possible.

LETTER STYLE

Type of letters used shall be those shown in the Standard Alphabets for Highway Signs book. As a guide to choice of alphabets, tests have show that, for any given legend, better legibility can be

obtained by using a relatively wide spacing between letters than by using wider and taller letters with a cramped space.

Sign lettering is normally uppercase letters except that destination names may be in lowercase lettering, with initial uppercase. The initial uppercase letters used in conjunction with lowercase letters will be Series E(M) and shall be approximately 1½ times the “loop” height of the lowercase letters.

Use of the Series B alphabet are for street name signs, parking signs, and other similar signs where limited breadth and stroke widths are required for design purposes.

SIZE OF LETTERING

For guide signs on expressways and freeways, the prescribed numeral and letter sizes, according to interchange classification and component of sign legend, appear in Tables 2E-1 through 2E-4 of the MUTCD. The minimum sizes specified should be exceeded where conditions indicate a need for greater legibility.

For conventional roads in rural districts on major routes, the principal legend on guide signs shall be in letters at least 6 inches (150 mm) in height. On low-volume roads and on urban streets with speeds of 25 mph (40 km/h), the principal legend shall be in letters at least 4 inches (100 mm) high.

Lettering on street name signs should be at least 6 inches (150 mm) high (MUTCD, Section 2D.38). Supplementary lettering to indicate type of street or section of city may be in smaller lettering but at least 3 inches (75 mm) high.

An accepted “rule-of-thumb” to follow for legibility for signs other than Interstate is to have 1 inch (25 mm) of letter height for every 40 feet (12 m) of desired legibility.

AMOUNT OF LEGEND

The MUTCD states that regardless of letter size, the legend on a guide sign must be kept to a minimum to be instantly legible. For example, on expressways, the legend on a guide sign should only have two destinations and the directional copy. Directional copy, not exceeding three lines,

may include symbols, route numbers, arrows, cardinal directions, interchange number(s), and other exit instructions. Conventional road guide signs should be limited to three lines of principal legend which includes only place names, route numbers, and street names.

ARROWS

In the Appendix, two sets of arrows are illustrated for use in highway signs. With few exceptions, which include guide signs, the “standard arrow” is for all types of signs. The “Up” and “Down” arrows are to be used for guide signs and recommended applications are stated in Sections 2D.8 and 2E.18 of the MUTCD.

BORDERS

With few exceptions, the MUTCD requires all signs to have a border of the same color as the legend. A dark border should be set in from the edge, while a white border should extend to the edge of the panel.

A suitable border for 30-inch (750 mm) signs with a light background should be from one-half to three-quarters of an inch (13 to 19 mm) in width, one-half inch (13 mm) from the edge. For similar signs with a white border, a width of one inch (25 mm) is appropriate. For other signs, the border widths should be of similar proportions but should not exceed the stroke width of the major lettering of the sign. For guide signs, smaller than 6 feet by 10 feet (1,800 x 3,000 mm), a width of approximately 1¼ inch (19 mm) may be used; for those exceeding 6 feet by 10 feet (1800 mm x 3000 mm), the border should be 2 inches (50 mm) wide; and for unusually large signs, a border of 3 inches (75 mm) wide is appropriate.

The corners of all sign borders shall be rounded and, where practicable, the corners of the sign panels should also be rounded to fit the border, except for STOP signs. On guide signs, corner radii of sign borders should be approximately one-eighth of the lesser side dimension except that the radii should not exceed 12 inches (300 mm) on any sign. The area outside the corner radius on large guide signs may need to be trimmed.

SPACING

Interline spacing should be approximately three-fourths the average of capital or uppercase letter heights in adjacent lines of letters.

The spacing to the top and bottom borders should be approximately equal to the average of the letter height of the adjacent line of letters. The lateral spacing to the vertical borders should be essentially the same as the height of the largest letter.

Spacing between words, words and arrow, a letter and arrow, or a word and number in a line copy should be approximately 1 to 1½ times the uppercase letter height used in that line of copy.

An example in the design of a guide sign using the above guidelines is shown on the following pages.

DIAGRAMMATIC SIGNS

Design of diagrammatic signs follow the same principles and guidelines previously covered plus additional guidelines necessary for the details related to the graphic components. Diagrammatic signs shall be designed in accordance with the following criteria:

1. The graphic legend shall be of a plan view showing a simplified off-ramp arrangement.
2. Only one destination may be shown for each arrowhead, with a maximum of two destinations per sign.
3. The graphic should not depict deceleration lanes. A black on yellow “EXIT ONLY” panel should be used to supplement a lane drop graphic.
4. The shaft for the exit ramp movement should be shorter than, but not separated from, the through movement graphic.
5. Arrow shafts should contain lane lines where appropriate and route shields shall not be used as a substitute for arrowheads.
6. Route shields, cardinal directions, and destinations should be clearly related to the arrowhead, and the arrowhead should point toward the route shield for the off movement.

7. The cardinal direction should generally be placed adjacent to the route shield and the destination should be placed below and justified with the route shield.

8. Exit number panels should be located toward the top left edge of the sign for a left exit and toward the top right edge for right exits.

The above guidelines were based upon the results of a research project conducted by the Federal Highway Administration. This research generated ideals for the various diagrammatic design features.

These ideal features have been modified so that more economical designs could not be obtained.

Specific design standards for graphic components are presented in the table below and other recommended features are shown in the design illustrations in the following pages. The illustrations shown were designed through a trial and error procedure and will provide the designer with the guides and elements needed to design an economical diagrammatic sign while maintaining a clear and simple message.

GRAPHIC COMPONENT	SIZE
Lane Width	5" (125 mm) *
Lane Lines	1" x 6" (25 x 150 mm)
Space between Lane Lines	6" (150 mm)
Arrowheads	Standard "Up" Arrow
Stem Height (to upper point of departure—minimum)	30" (750 mm)
Space between arrowhead and route shield and between route shield and cardinal direction	12" (300 mm)*

* Wider lane widths appear to better meet the needs of older drivers.



2004 EDITION

English Version

Standard Highway Signs

Including Pavement Markings and Standard Alphabets

2012 SUPPLEMENT

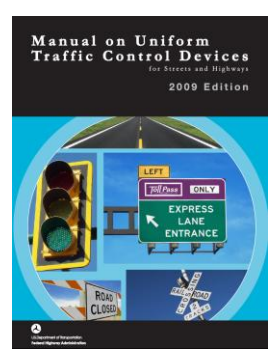

For use with the 2009 Manual on Uniform Traffic Control Devices for Streets and Highways

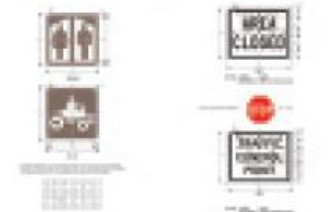
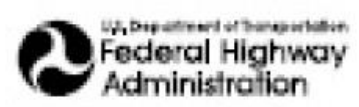

Standard Highway Signs 2004 Edition

2012 SUPPLEMENT

Preface

The information contained herein reflects the new and revised sign designs that have been adopted in the 2009 Edition of the *Manual on Uniform Traffic Control Devices for Streets and Highways* (MUTCD). This Supplement serves as an interim update until a new edition of the *Standard Highway Signs and Markings* publication is released at a future date. The sign designs contained in this Supplement will be incorporated into the new edition of *Standard Highway Signs and Markings*. The new edition, currently in progress, will contain expanded sign design guidelines, the Standard Alphabets, and updated information for standard arrow designs, pavement markings, and symbolic traffic control signal indications.

The new and updated sign designs in this Supplement supersede any previous designs for the same signs contained in the 2004 Edition of *Standard Highway Signs*.

March 2012

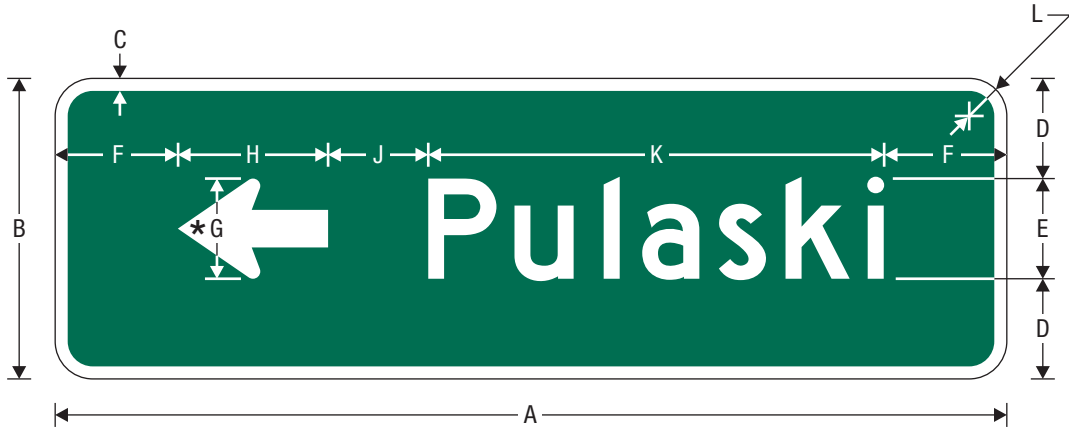

D1-1
DESTINATION (1 LINE)

* See page 6-2 for arrow design.

A	B	C	D	E	F	G	H	J	K	L
VAR	18	0.75	6	6 D	6 MIN	6	9	6	VAR	2.25
VAR	24	1	8	8 D	8 MIN	8	12	8	VAR	3

COLORS: LEGEND, BORDER – WHITE (RETROREFLECTIVE)
BACKGROUND – GREEN (RETROREFLECTIVE)

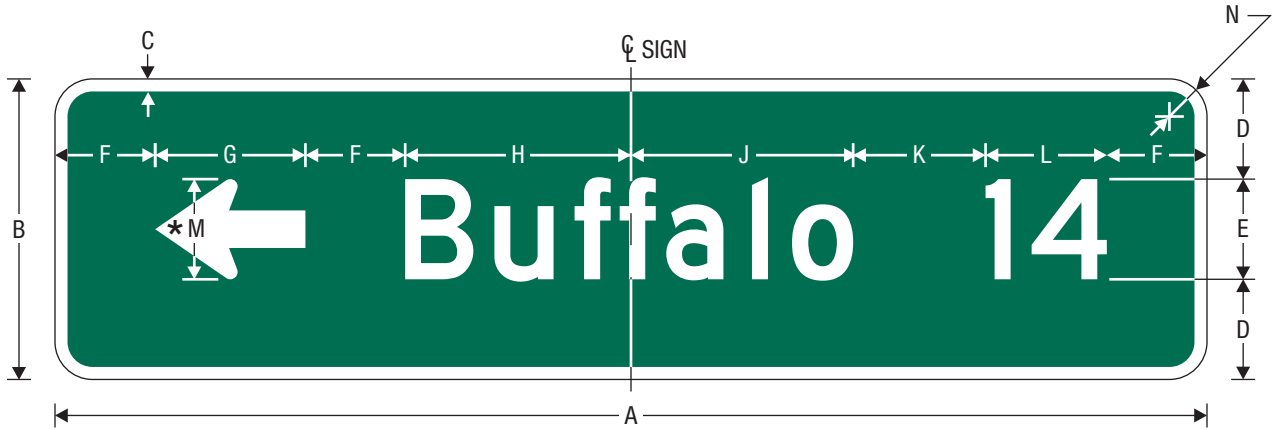

D1-1a
 DESTINATION AND DISTANCE (1 LINE)

* See page 6-2 for arrow design.

A	B	C	D	E	F	G	H	J	K	L	M	N
VAR	18	0.75	6	6 D	6	9	VAR	VAR	6 MIN	VAR	6	2.25
VAR	24	1	8	8 D	8	12	VAR	VAR	8 MIN	VAR	8	3

COLORS: LEGEND, BORDER – WHITE (RETROREFLECTIVE)
 BACKGROUND – GREEN (RETROREFLECTIVE)

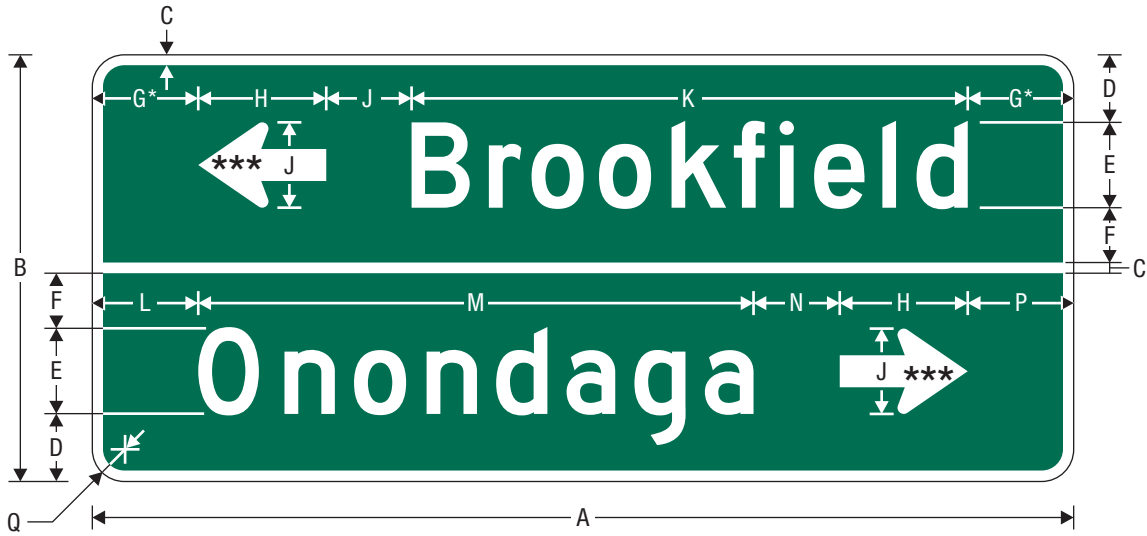

D1-2
DESTINATION (2 LINES)

- * Controlling line of legend.
- ** Optically space non-controlling line.
- *** See page 6-2 for arrow design.

A	B	C	D	E	F	G	H	J	K
VAR	30	0.75	4.75	6 D	3.875	6 MIN*	9	6	VAR
VAR	42	1	6.75	8 D	5.75	8 MIN*	12	8	VAR

L	M	N	P	Q
6 MIN**	VAR	6 MIN, 9 MAX	6 MIN**	2.25
8 MIN**	VAR	8 MIN, 12 MAX	8 MIN**	3

COLORS: LEGEND, BORDER – WHITE (RETROREFLECTIVE)
BACKGROUND – GREEN (RETROREFLECTIVE)



D1-2a
 DESTINATION AND DISTANCE (2 LINES)

* See page 6-2 for arrow design.

A	B	C	D	E	F	G	H	J	K	L	M
VAR	30	0.75	4.75	6 D	3.875	6	9	6	VAR	6 MIN	VAR
VAR	42	1	6.75	8 D	5.75	8	12	8	VAR	8 MIN	VAR
N	P	Q	R								
VAR	6 MIN	VAR	2.25								
VAR	8 MIN	VAR	3								

COLORS: LEGEND, BORDER – WHITE (RETROREFLECTIVE)
 BACKGROUND – GREEN (RETROREFLECTIVE)

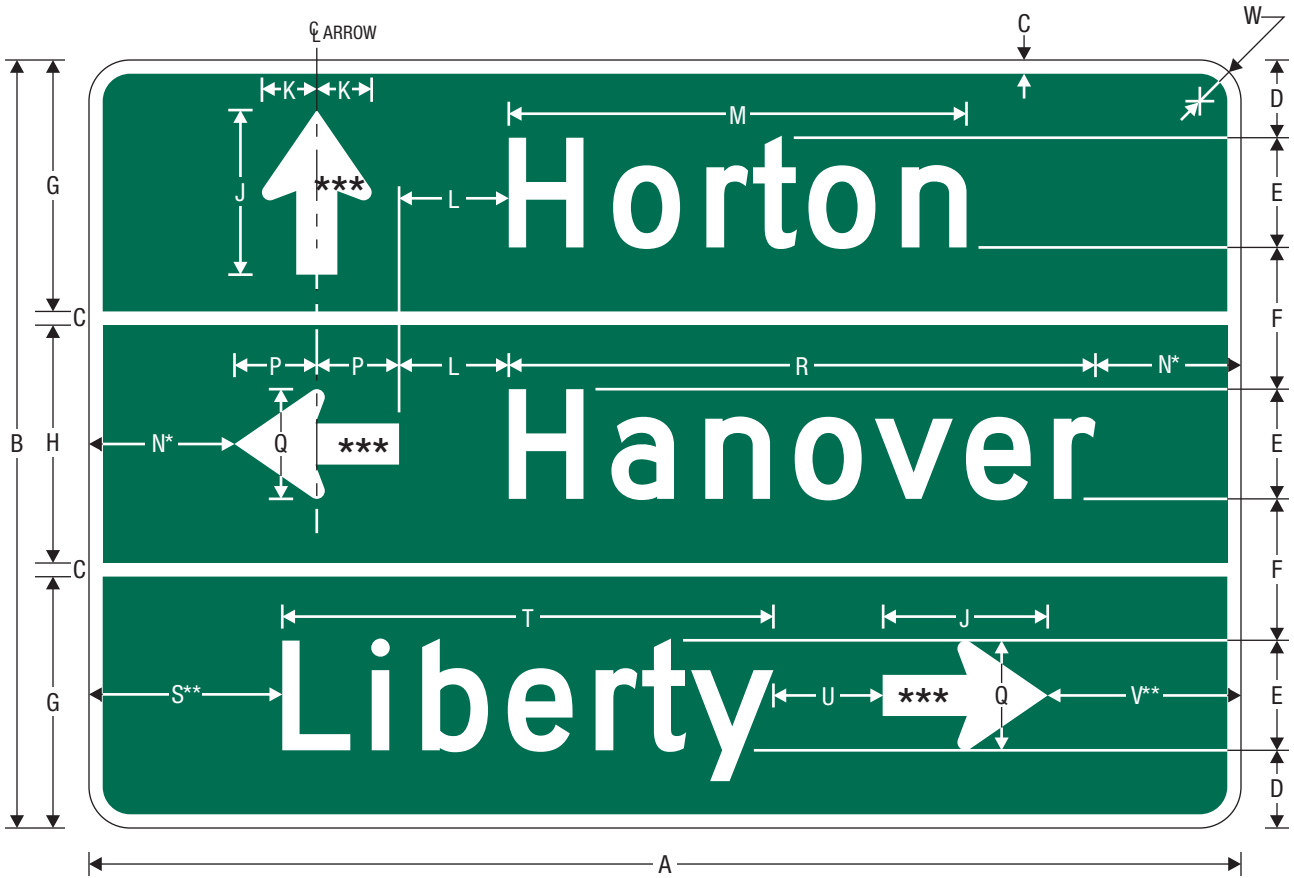

D1-3
DESTINATION (3 LINES)

- * Controlling line of legend.
- ** Optically space non-controlling line.
- *** See page 6-2 for arrow design.

A	B	C	D	E	F	G	H	J	K	L	M
VAR	42	0.75	4.25	6 D	7.75	13.75	13	9	3	6	VAR
VAR	60	1	6.25	8 D	11.75	19.5	19	12	4	8	VAR

N	P	Q	R	S	T	U	V	W
6 MIN*	4.5	6	VAR	6 MIN**	VAR	6 MIN, 9 MAX	6 MIN**	2.25
8 MIN*	6	8	VAR	8 MIN**	VAR	8 MIN, 12 MAX	8 MIN**	3

COLORS: LEGEND, BORDER – WHITE (RETROREFLECTIVE)
BACKGROUND – GREEN (RETROREFLECTIVE)

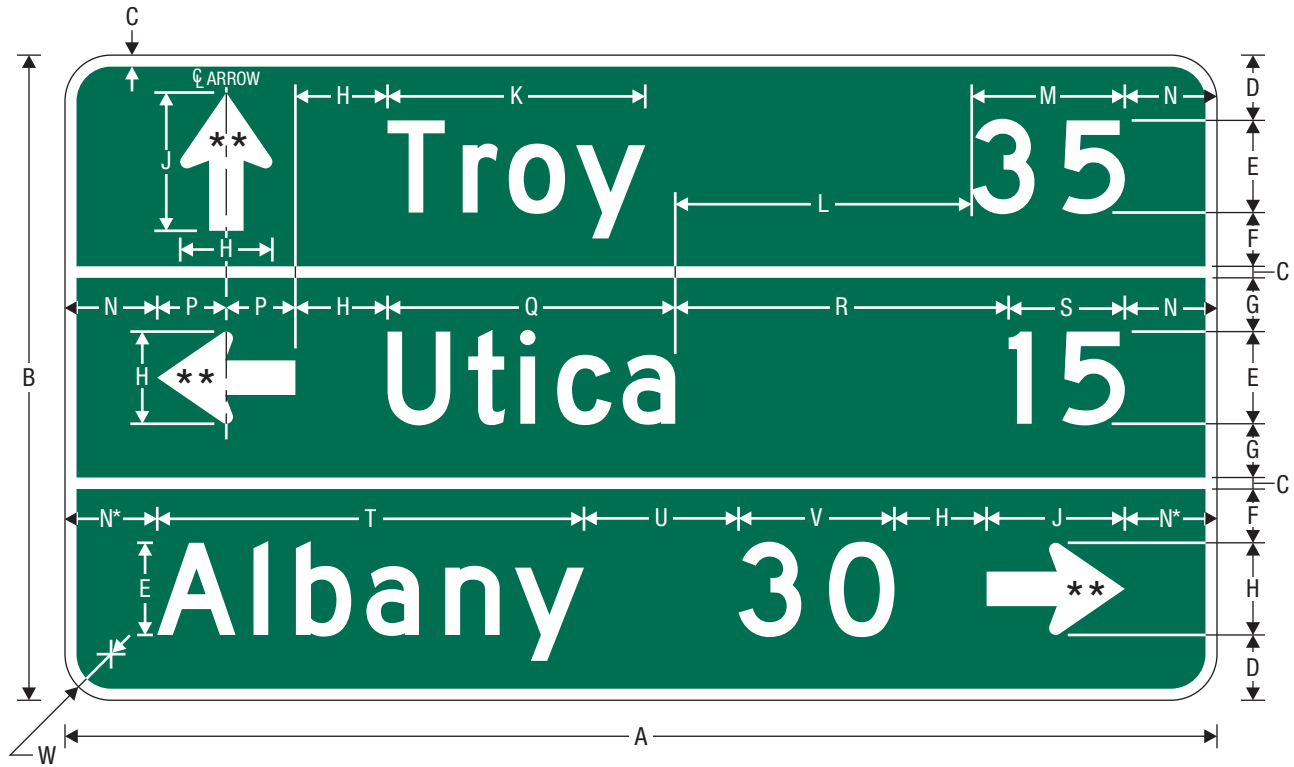

D1-3a

DESTINATION AND DISTANCE (3 LINES)

* Controlling line of legend.

** See page 6-2 for arrow design.

A	B	C	D	E	F	G	H	J	K	L	M
VAR	42	0.75	4.25	6 D	3.5	3.5	6	9	VAR	9 MIN	VAR
VAR	60	1	6.25	8 D	5.25	5.5	8	12	VAR	12 MIN	VAR
N	P	Q	R	S	T	U	V	W			
6 MIN	4.5	VAR	9 MIN	VAR	VAR	9 MIN	VAR	3			
8 MIN	6	VAR	12 MIN	VAR	VAR	12 MIN	VAR	3			

COLORS: LEGEND, BORDER – WHITE (RETROREFLECTIVE)
BACKGROUND – GREEN (RETROREFLECTIVE)

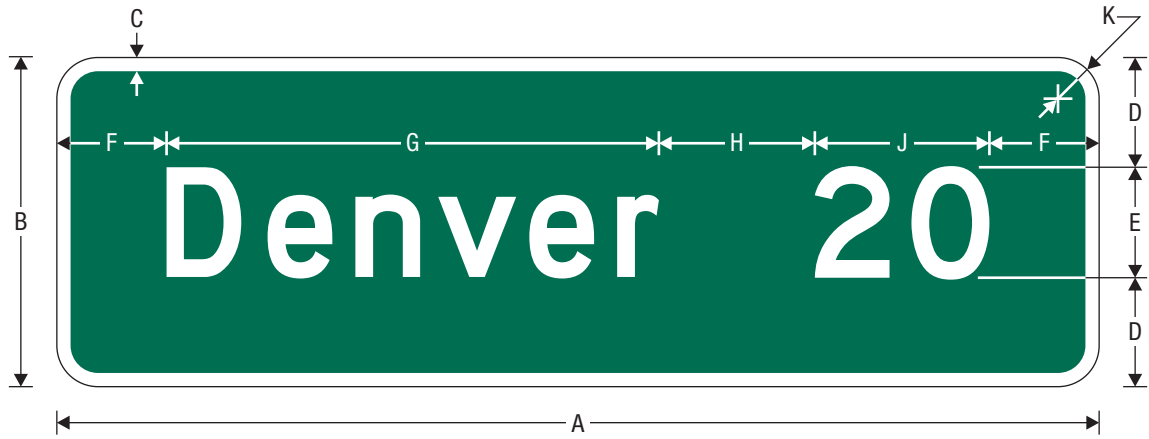

D2-1
DISTANCE (1 LINE)

A	B	C	D	E	F	G	H	J	K
VAR	18	0.75	6	6 D	6	VAR	6 MIN	VAR	2.25
VAR	24	1	8	8 D	8	VAR	8 MIN	VAR	3

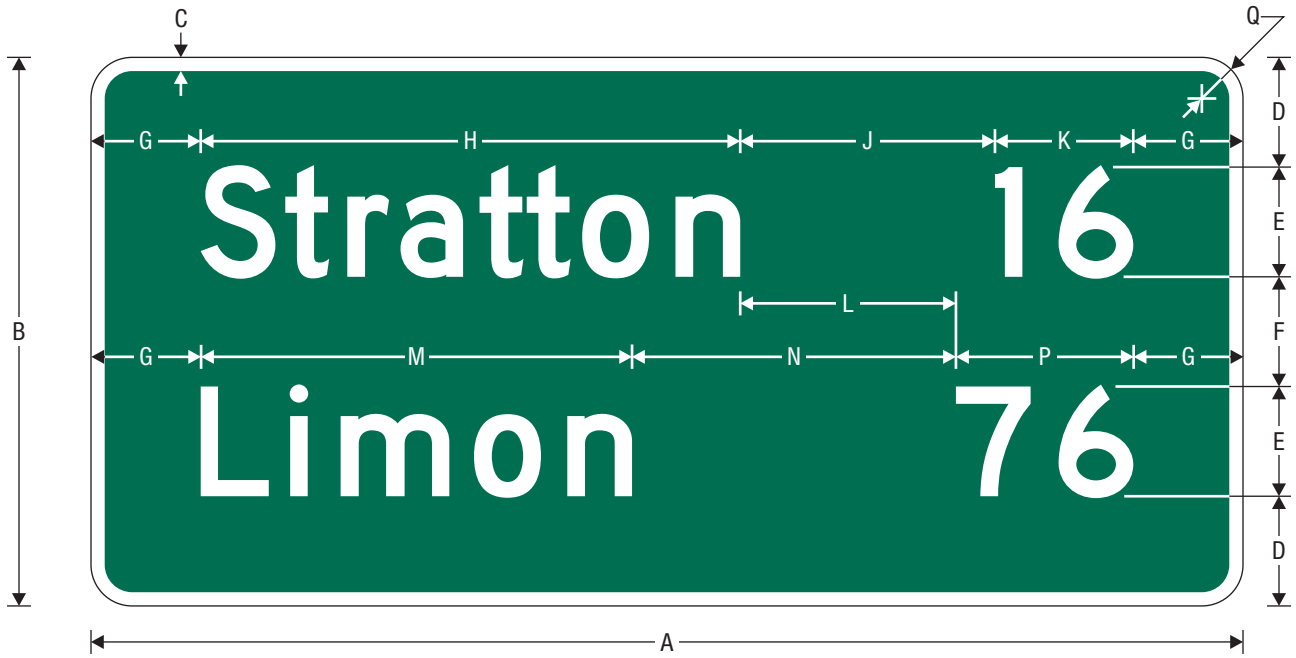

D2-2
DISTANCE (2 LINES)

A	B	C	D	E	F	G	H	J	K	L	M	N	P	Q
VAR	30	0.75	6	6 D	6	6	VAR	9 MIN	VAR	9 MIN	VAR	VAR	VAR	2.25
VAR	36	1	7	8 D	6	8	VAR	12 MIN	VAR	12 MIN	VAR	VAR	VAR	3

COLORS: LEGEND, BORDER – WHITE (RETROREFLECTIVE)
BACKGROUND – GREEN (RETROREFLECTIVE)

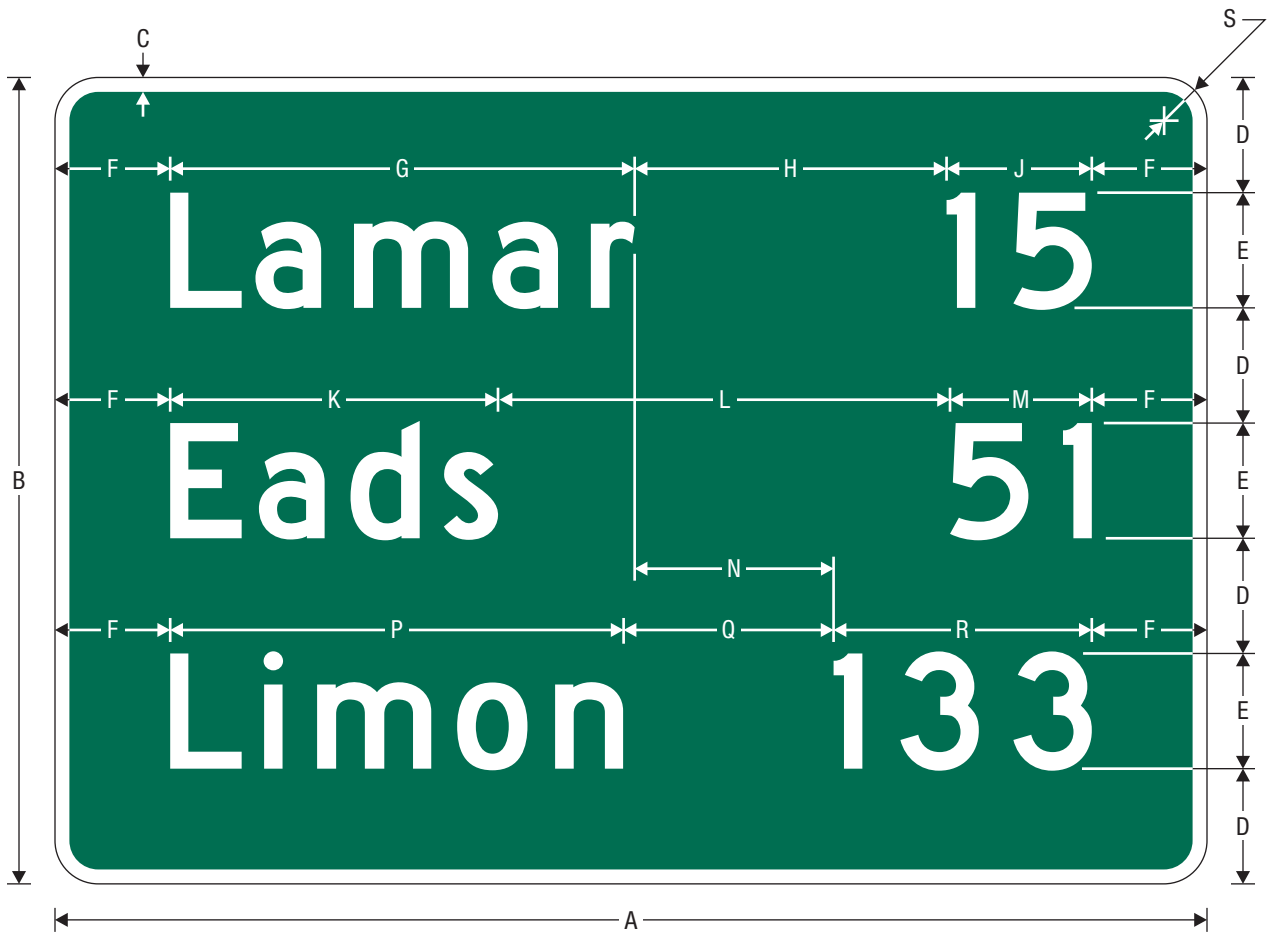

D2-3
DISTANCE (3 LINES)

A	B	C	D	E	F	G	H	J	K	L	M	N
VAR	42	0.75	6	6 D	6	VAR	9 MIN	VAR	VAR	VAR	VAR	9 MIN
VAR	48	1	4.5	8 D	8	VAR	12 MIN	VAR	VAR	VAR	VAR	12 MIN

P	Q	R	S
VAR	VAR	VAR	2.25
VAR	VAR	VAR	3

COLORS: LEGEND, BORDER – WHITE (RETROREFLECTIVE)
BACKGROUND – GREEN (RETROREFLECTIVE)

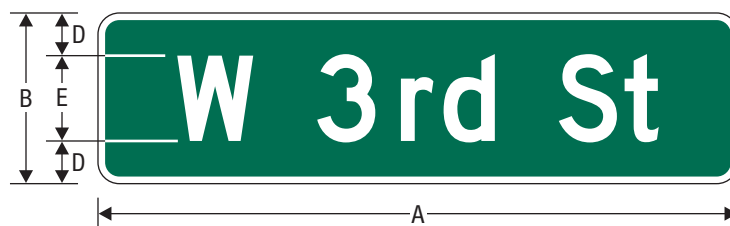
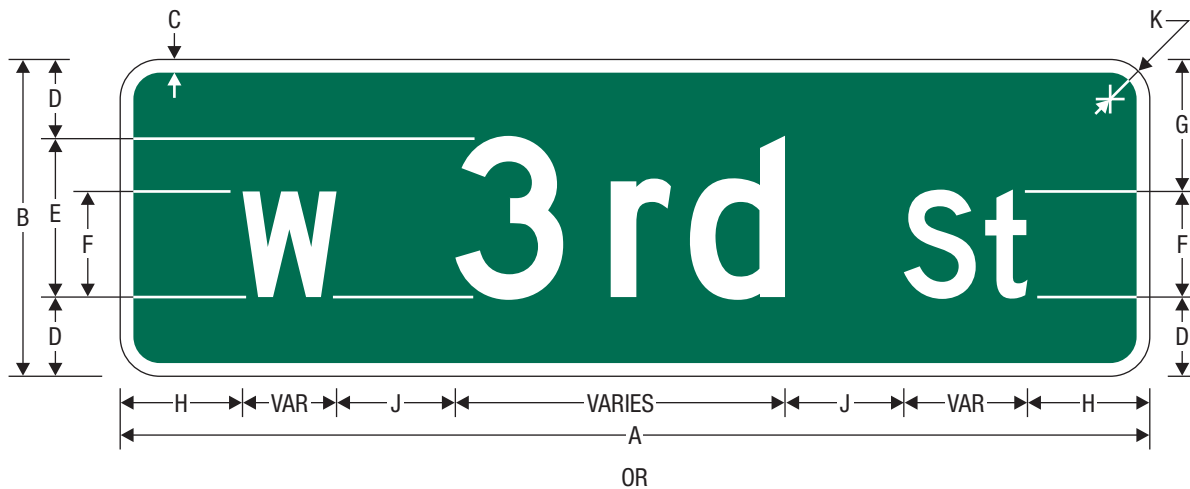

D3-1
STREET NAME SIGN



D3-1 – PRINCIPAL LEGEND WITH DESCENDING STROKES



D3-1 – WITHOUT BORDER, PRINCIPAL LEGEND WITH OR WITHOUT DESCENDING STROKES

A	B	C	D	E	F	G	H	J	K	L	M	N
VAR	8	0.375	2	4 D	3 D	3	3 (MIN)	3	1	1.75	2.25	2.75
VAR	12	0.5	3	6 D	4 D	5	4.5 (MIN)	4.5	1.5	2.75	3.25	4.75
VAR	18	0.75	5	8 D	5.33 D	7.67	5.33 (MIN)	6	1.875	5	5	7.67
VAR	24	1	6	12 D	8 D	10	9 (MIN)	9	2.25	5.5	6.5	9.5

COLORS: LEGEND, BORDER – WHITE (RETROREFLECTIVE)
 BACKGROUND – GREEN (RETROREFLECTIVE)
 BACKGROUND (ALTERNATE) – BLUE OR BROWN (RETROREFLECTIVE)

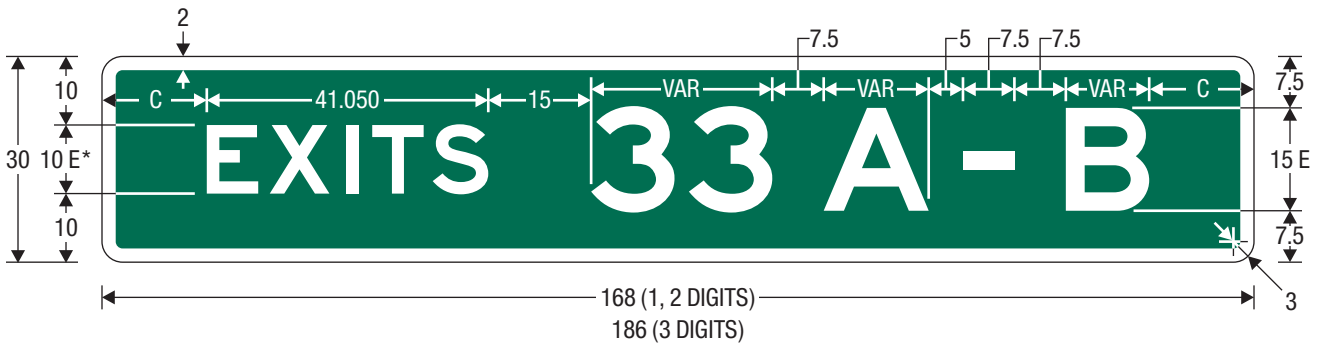
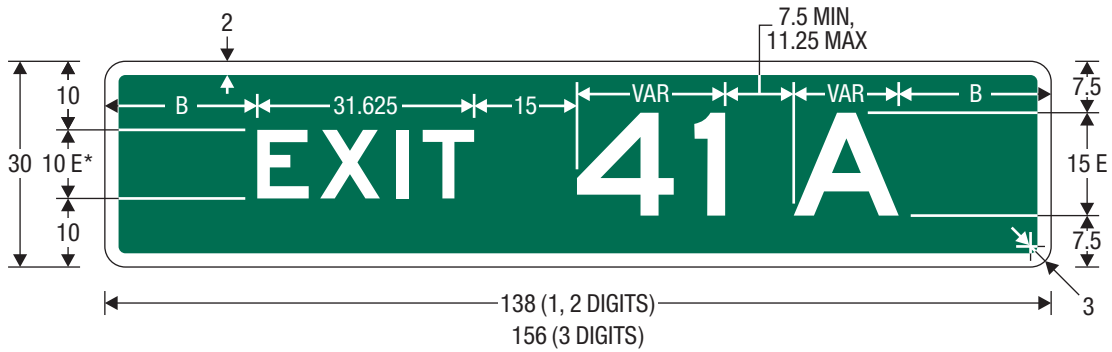
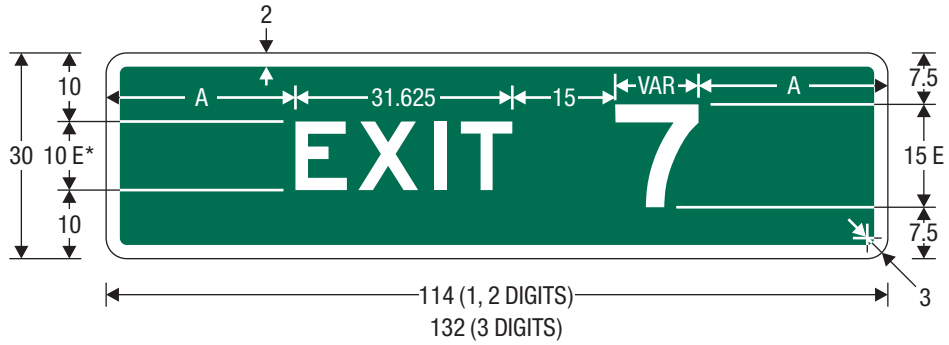

E1-5P
 EXIT NUMBER (PLAQUE)

* Increase character spacing 20%.

COLORS: LEGEND, BORDER — WHITE (RETROREFLECTIVE)
 BACKGROUND — GREEN (RETROREFLECTIVE)

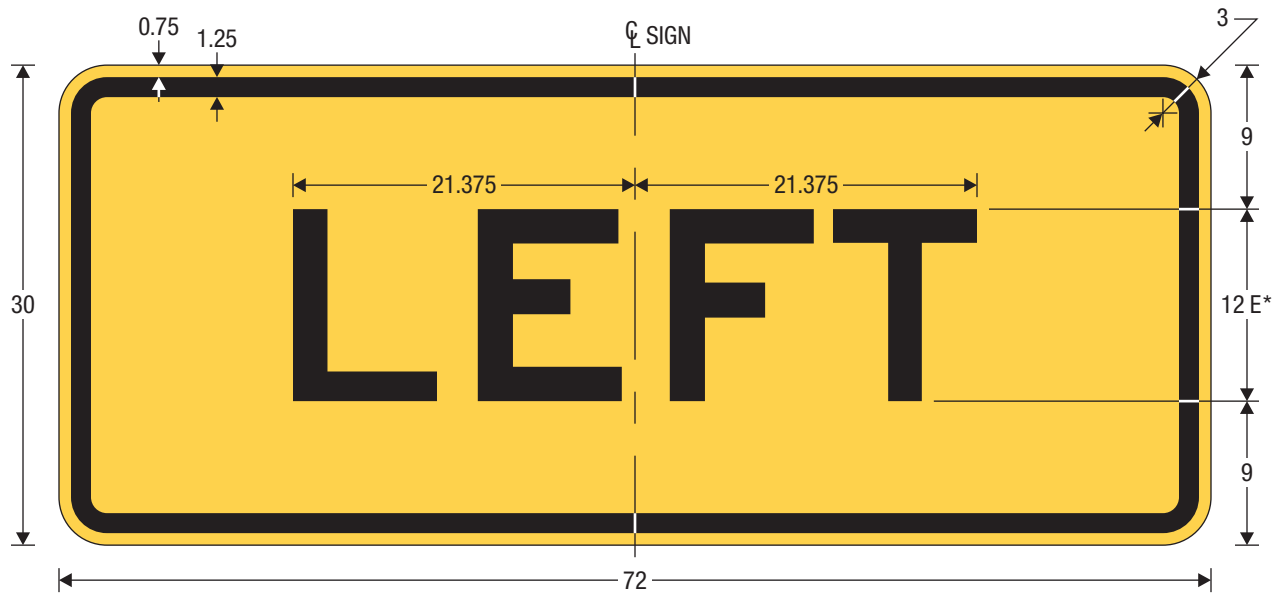

E1-5aP
LEFT (PLAQUE)

* Increase character spacing 25%.

COLORS: LEGEND, BORDER — BLACK
BACKGROUND — YELLOW (RETROREFLECTIVE)

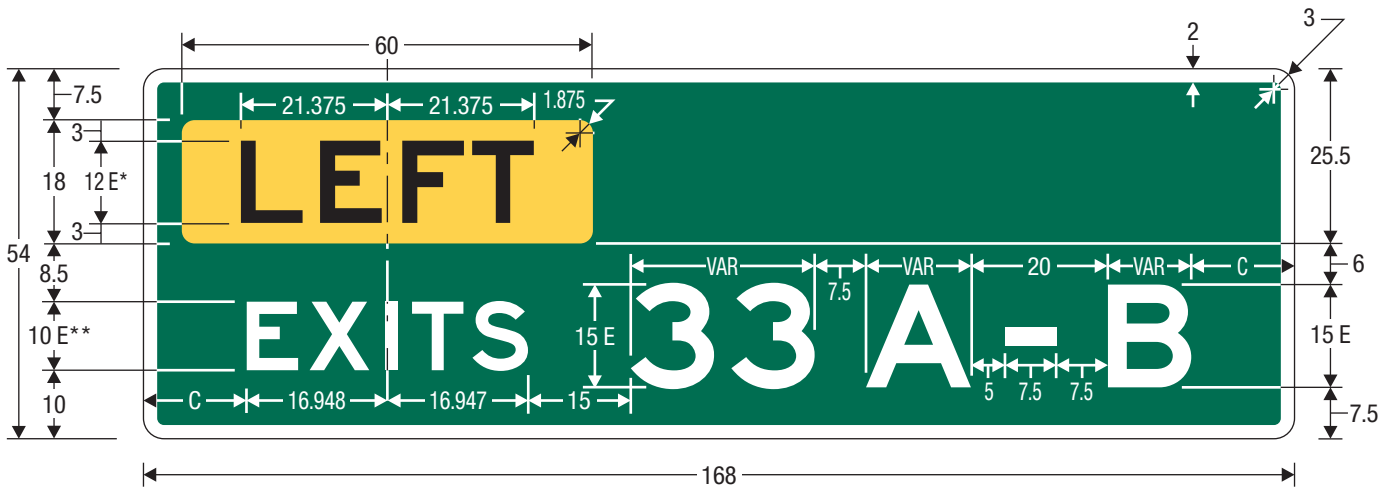
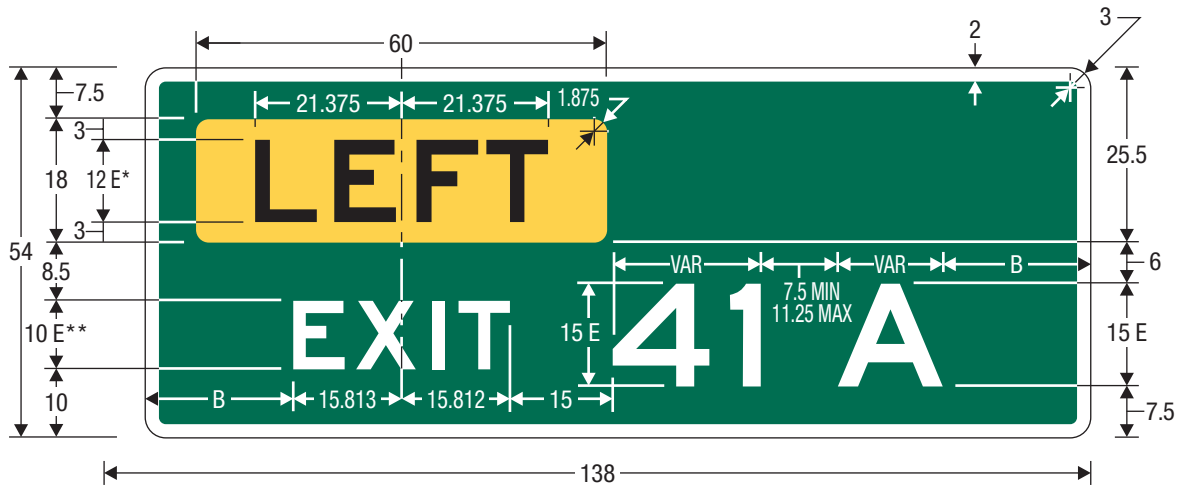
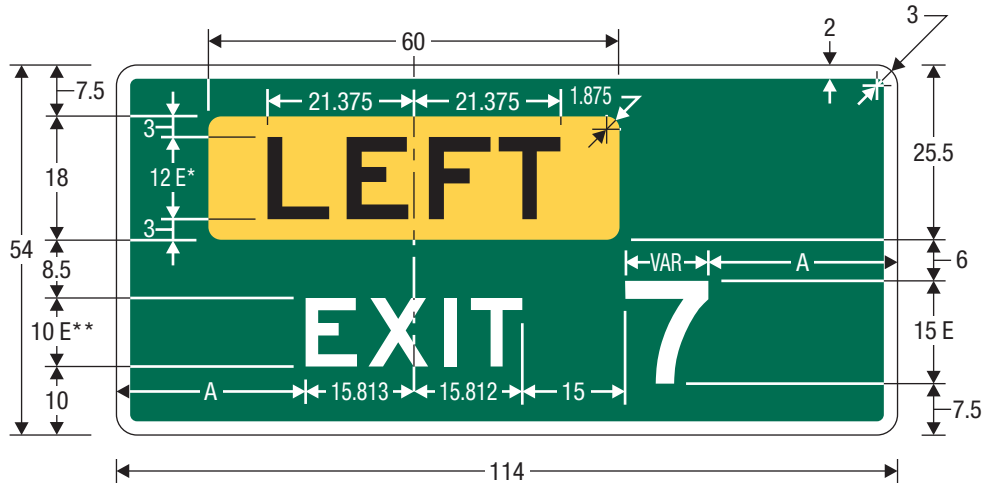

E1-5bP
 LEFT EXIT NUMBER (PLAQUE)

- * Increase character spacing 25%.
- ** Increase character spacing 20%.

COLORS: LEGEND, BORDER — WHITE (RETROREFLECTIVE)
 BACKGROUND — GREEN (RETROREFLECTIVE)

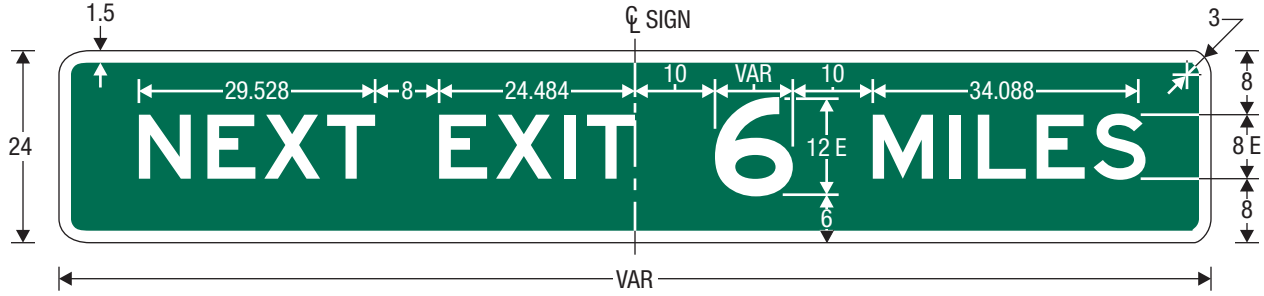

E2-1P
 NEXT EXIT (1-LINE PLAQUE)

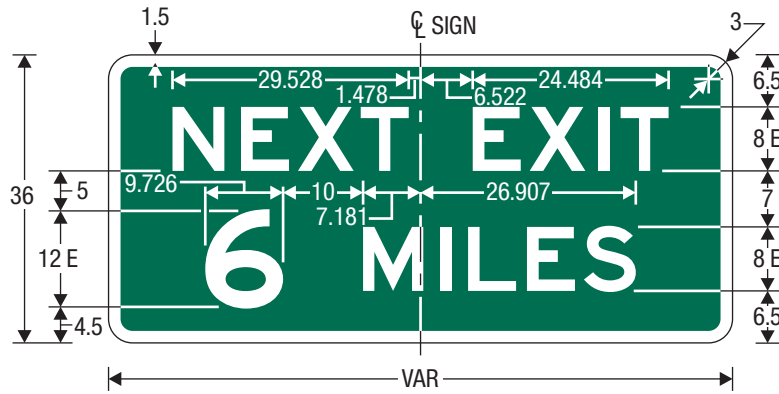

E2-1aP
 NEXT EXIT (2-LINE PLAQUE)

COLORS: LEGEND, BORDER — WHITE (RETROREFLECTIVE)
 BACKGROUND — GREEN (RETROREFLECTIVE)

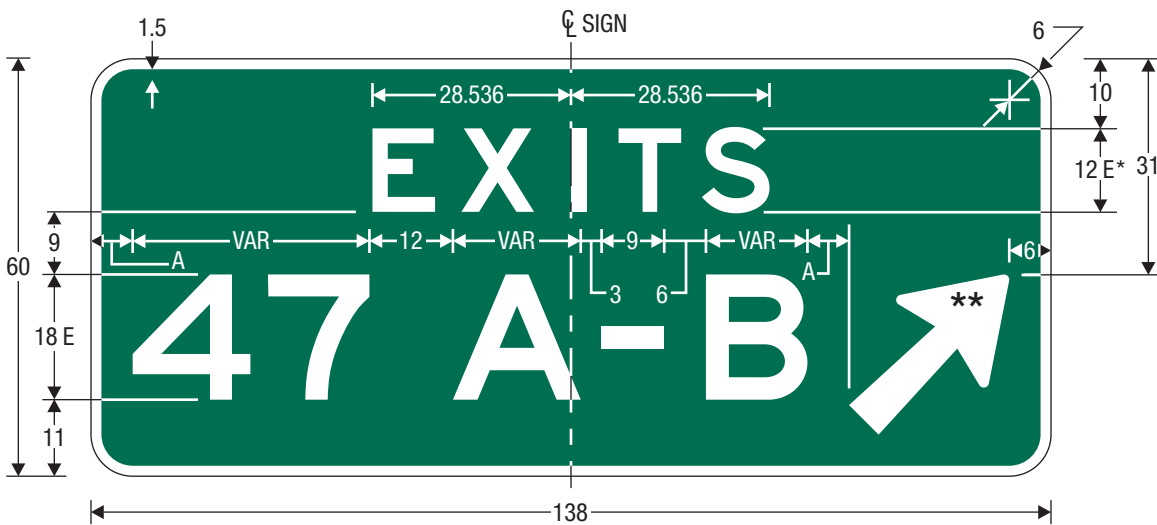
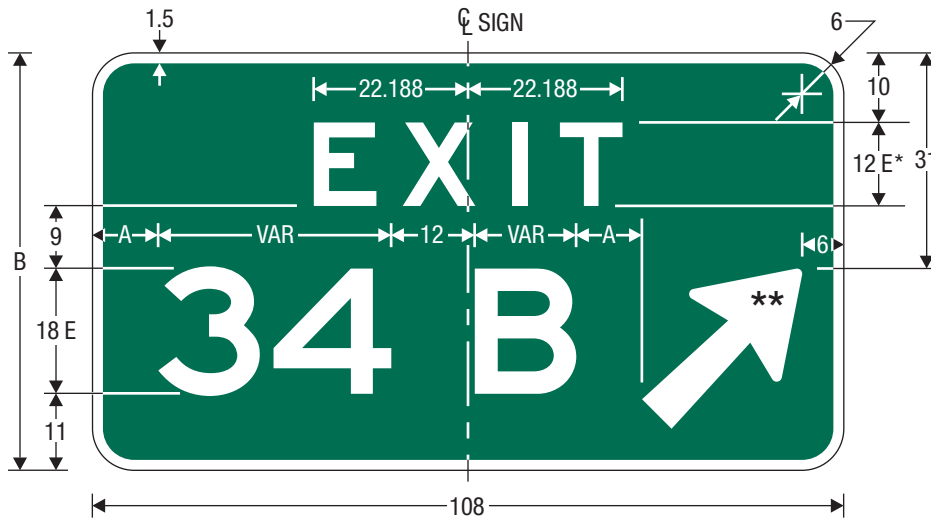
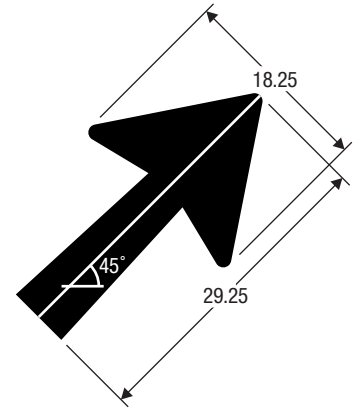
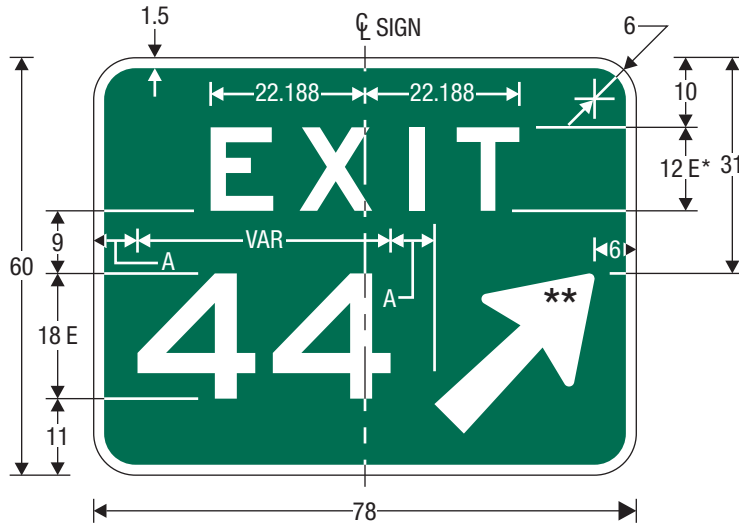

E5-1a

EXIT GORE - NUMBER

* Increase character spacing 225%.

** See page 6-1 for arrow design.

COLORS: LEGEND, BORDER — WHITE (RETROREFLECTIVE)
BACKGROUND — GREEN (RETROREFLECTIVE)

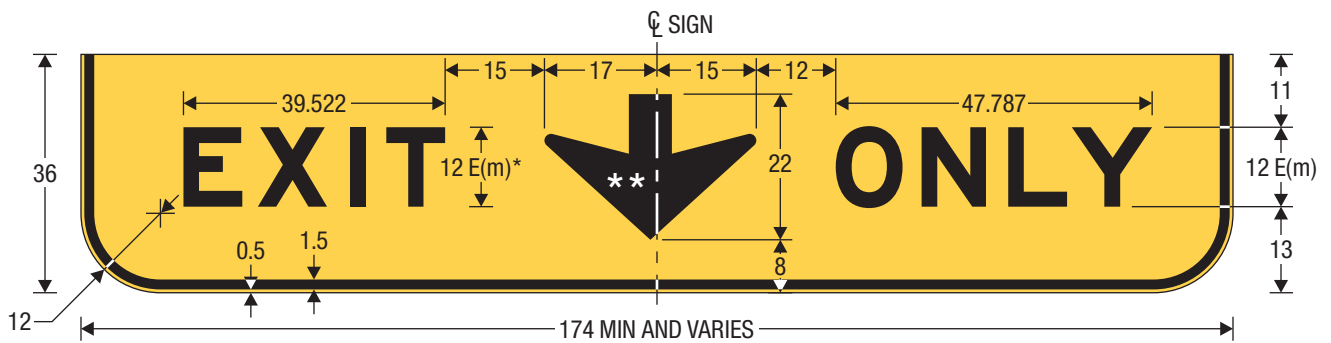

E11-1
EXIT ONLY (DOWN ARROW)

- * Increase character spacing 40%.
- ** See page 6-3 for arrow design.

COLORS: LEGEND, BORDER — BLACK
BACKGROUND — YELLOW (RETROREFLECTIVE)

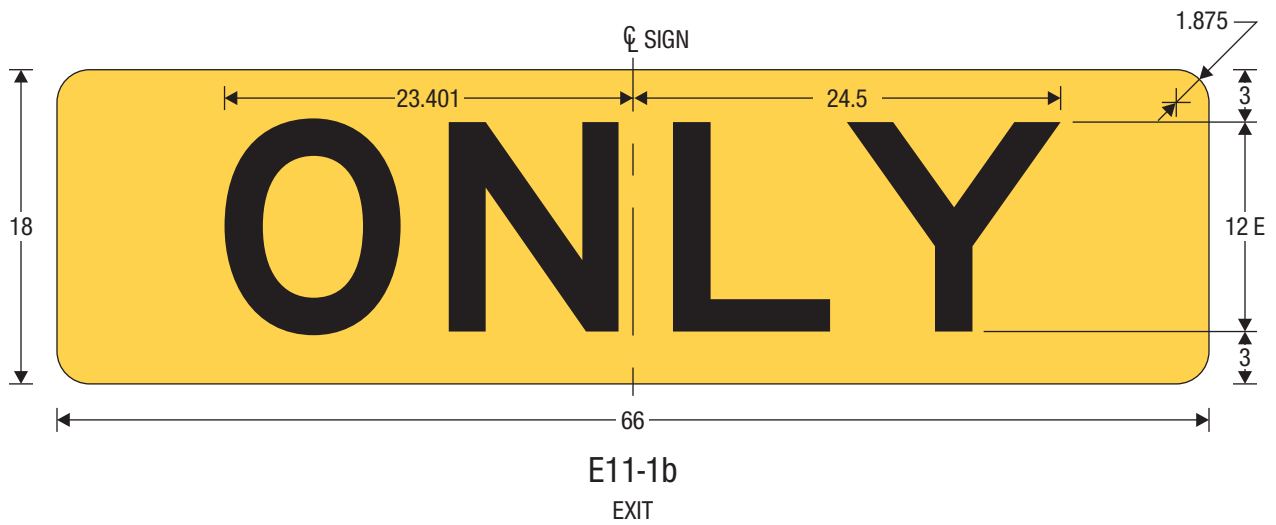
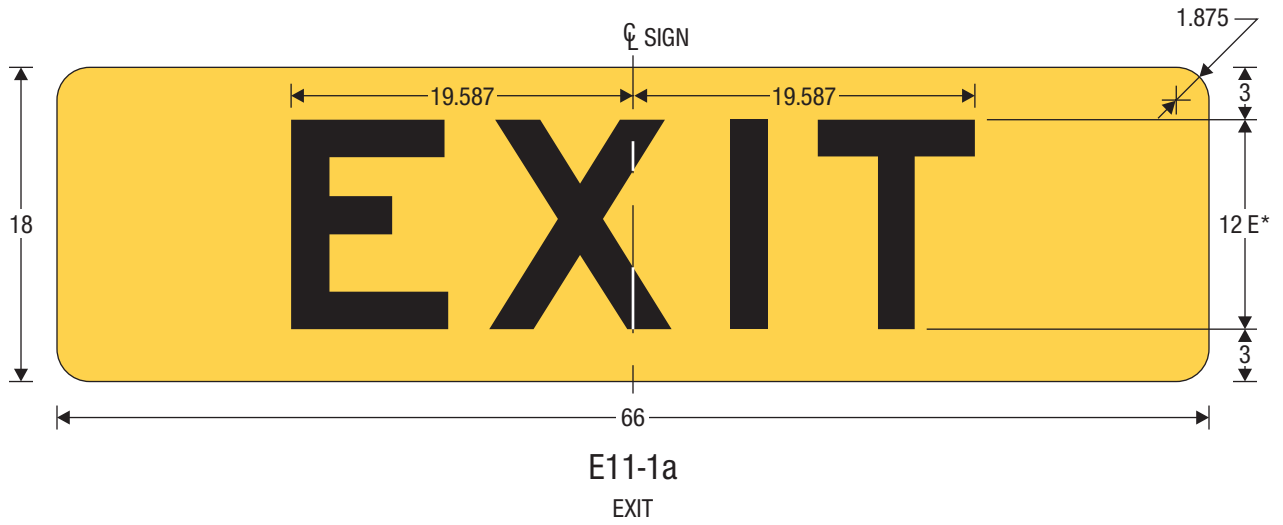

* Increase character spacing 40%.

COLORS: LEGEND — BLACK
BACKGROUND — YELLOW (RETROREFLECTIVE)
NO BORDER

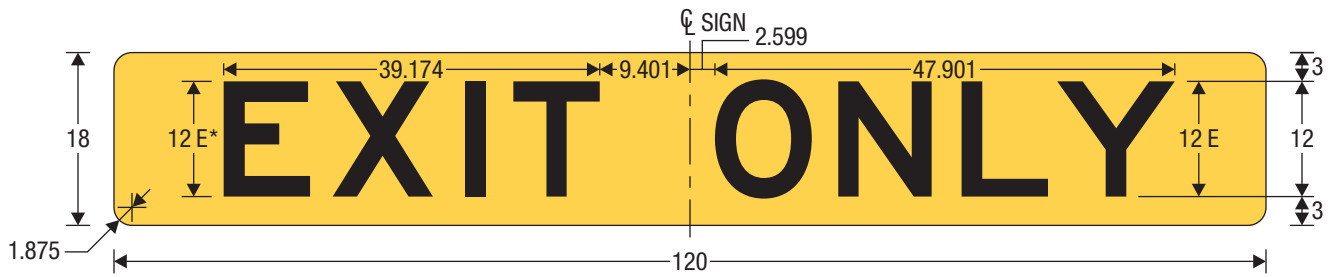

E11-1c
EXIT ONLY

* Increase character spacing 40%.

COLORS: LEGEND — BLACK
BACKGROUND — YELLOW (RETROREFLECTIVE)
NO BORDER

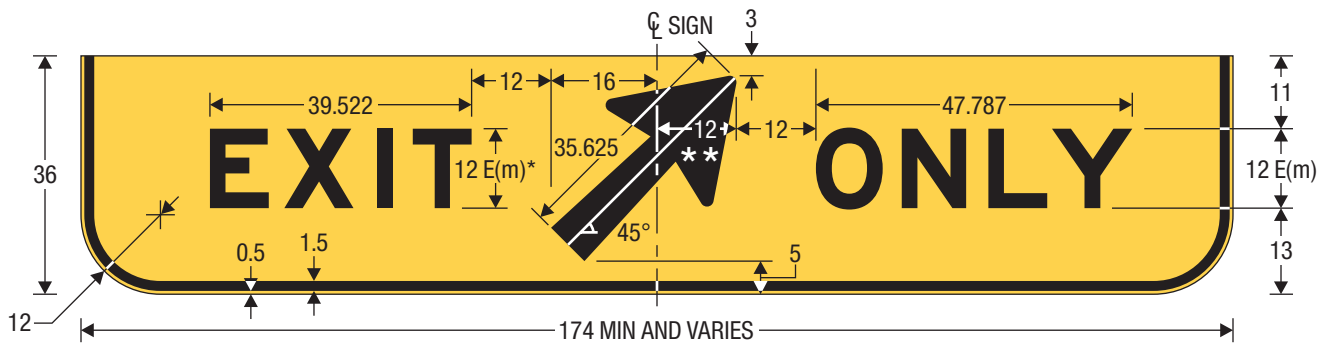

E11-1d
EXIT ONLY (EXIT DIRECTION)

- * Increase character spacing 40%.
- ** Type A arrow. See page 6-1 for design.

COLORS: LEGEND, BORDER — BLACK
BACKGROUND — YELLOW (RETROREFLECTIVE)

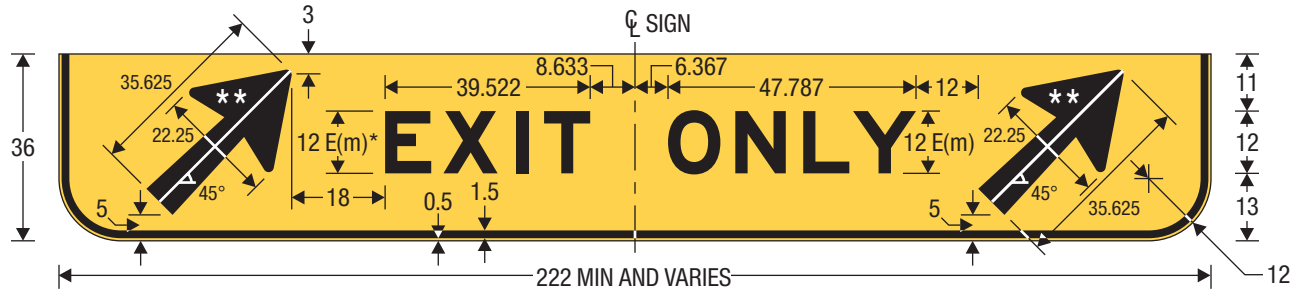

E11-1e
 EXIT ONLY (EXIT DIRECTION)

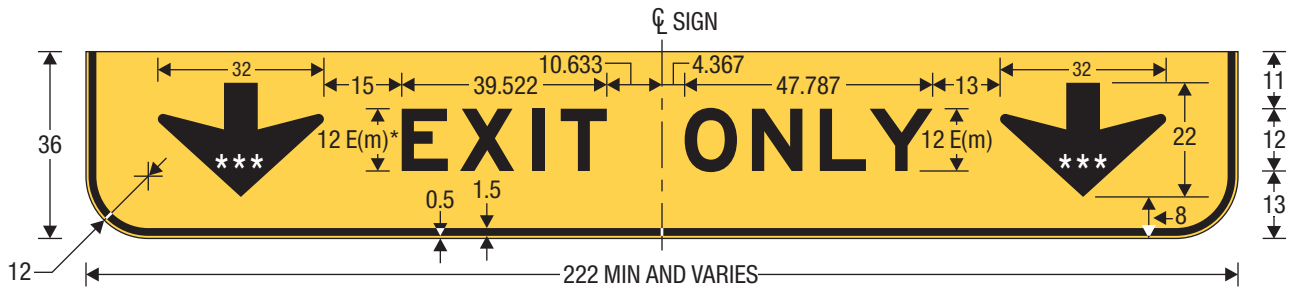

E11-1f
 EXIT ONLY (2 DOWN ARROWS)

- * Increase character spacing 40%.
- ** Type A arrow. See page 6-1 for design.
- *** See page 6-3 for arrow design.

COLORS: LEGEND, BORDER — BLACK
 BACKGROUND — YELLOW (RETROREFLECTIVE)

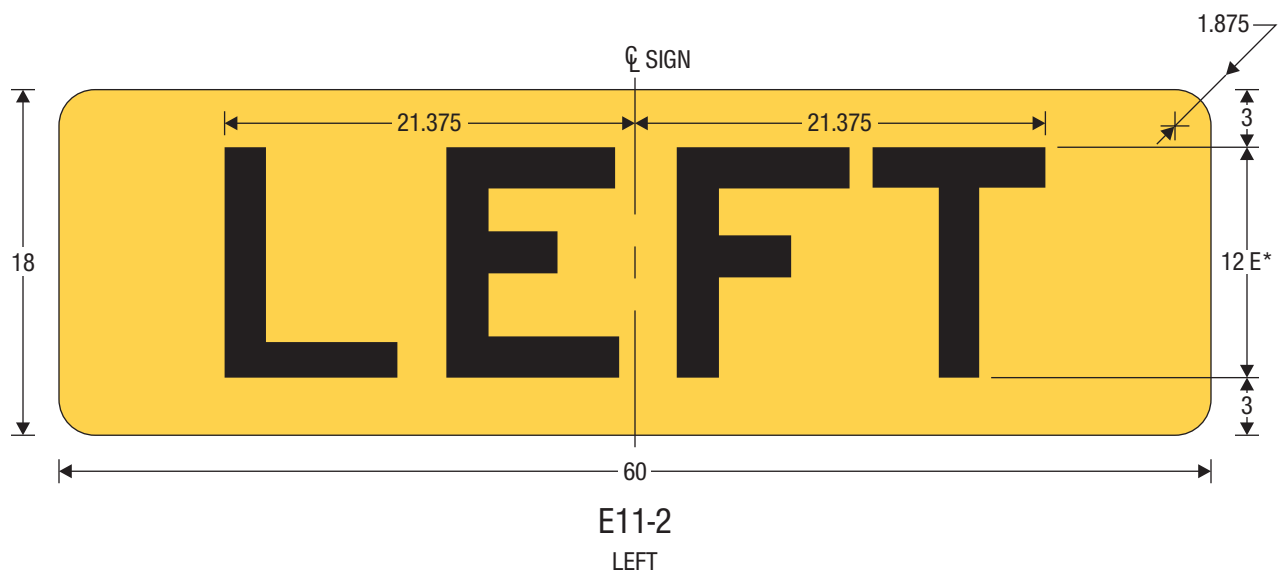

* Increase character spacing 25%.

COLORS: LEGEND — BLACK
BACKGROUND — YELLOW (RETROREFLECTIVE)
NO BORDER

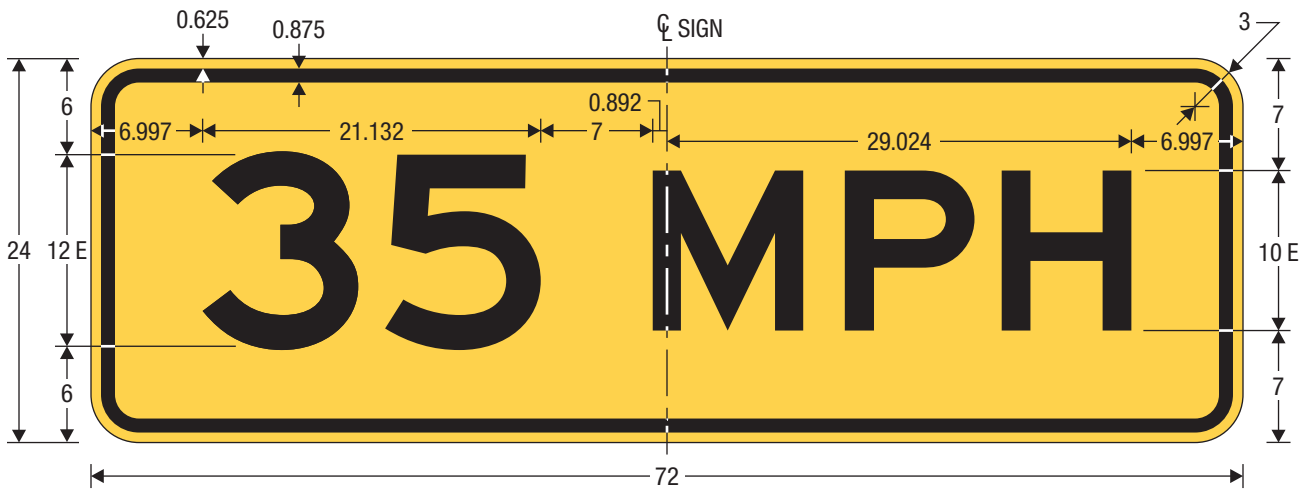

E13-1P
EXIT GORE ADVISORY SPEED (PLAQUE)

COLORS: LEGEND, BORDER — BLACK
BACKGROUND — YELLOW (RETROREFLECTIVE)

SIGN CROSS SECTION SHEETS

SIGN CROSS SECTION SHEETS

GROUND MOUNTED SIGN INSTALLATIONS

- Cross sections are required for all ground mounted sign installations that are to be installed on beam posts. See Figure 14 for an example of this cross section.
- Cross sections are not required for ground mounted sign installations that are to be installed on “U” channel or square tube posts unless it is an exit gore sign.
- A scale of 1”=5’ should be used for ground mounted sign cross sections.
- Show the design wind velocity as shown on drawing IHS-710-1 and the dimensions of all panels and the size of the required posts.

OVERHEAD SIGN INSTALLATIONS

- Cross sections are required for all overhead sign structures and existing overhead sign structures that are to be renovated or relocated. See Figure 15 for an example of this cross section.
- A scale of 1”=5’ should be used for overhead sign cross sections.
- On cross sections for existing overhead sign structures to be renovated, show the location and sizes (if possible) of existing sign panels and the new proposed location of these repositioned and/or any new required panels.
- Show the pavement and lane widths. Show the required guardrail as well as dimensions for the required structure and all panels. Show the minimum vertical clearance for the structure.
- Show the design wind velocity as shown on drawing IHS-710-1.
- Show the total required or design sign panel area.
- Reference the soil data sheets to the cross section sheets if they are to be included in the plans.
- There should be an overhead sign installation at every exit or interchange with an option lane.

POST INFORMATION FOR GROUND MOUNTED SIGN INSTALLATIONS

- All destination signs and exit gore signs should be mounted on “U” channel or square tube posts.
- Use standard drawings IHS-710-1, IHS-710-2 and IHS-710-3 for the design of beam posts required for ground mounted sign installations.
- For sign panels that are 18’ wide or greater, 3 post should be required. Otherwise review drawings IHS-710-2 and IHS-710-3 to determine the actual number of required posts.
- The post spacing for ground mounted signs requiring 2 post are as follows:
 - a. From the left side of the panel to the first post = 20% of the total width of the proposed panel.
 - b. The distance between the two posts = 60% of the total width of the proposed panel.
 - c. From the right side of the panel to the second post = 20% of the total width of the proposed panel.
- The post spacing for ground mounted signs requiring 3 post are as follows:
 - a. From the left side of the panel to the first post = 15% of the total width of the proposed panel.
 - b. The distance between the each of the three posts = 35% of the total width of the proposed panel.
 - c. From the right side of the panel to the third post = 15% of the total width of the proposed panel.
- If the dimension between the required posts as described in b in the above two bullets is 66” or greater, use drawing IHS-710-2 to determine the required size of the beam post. Show this as a Type 1 Base Connection.
- If the dimension between the required posts as described in b in the above two bullets is 66” or less, use drawing IHS-710-3 to determine the required size of the beam post. Show this as a Type 2 Base Connection.

SIGNING CROSS SECTION

REFERENCE PROJECT NO	FISCAL YEAR	SHEET NO
ACIM59761-ATRP(001)	2014	36

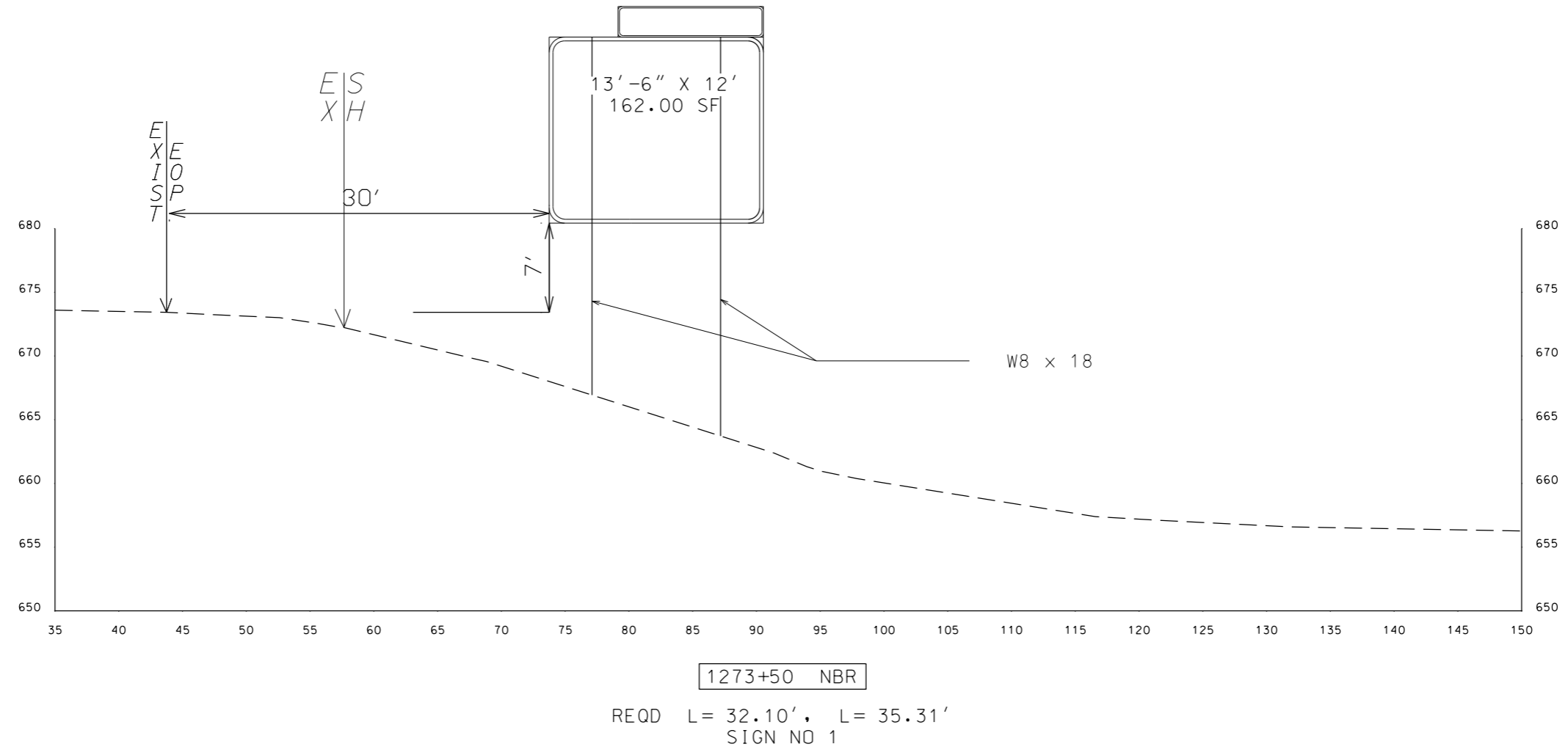

Sta. 1273+50 To Sta. 1273+50

FIGURE 14

Y:\projects\100048777\Project_Design\Plans_Assembly\48777_stripe_35_35F_ETC_SHEETS.dgn 4/10/2014 4:07:05 PM franks

RESPONSIBLE PE:	SUPERVISOR:	DESIGNER:	PLAN SUBMITTAL	ALABAMA DEPARTMENT OF TRANSPORTATION DESIGN BUREAU SECTION D3	HORIZ SCALE (FEET)	SHEET TITLE	ROUTE
DATE:	DATE:	DATE:	OE			SIGNING CROSS SECTION 78	I-65

SIGNING CROSS SECTIONS

REFERENCE PROJECT NO	FISCAL YEAR	SHEET NO
NHF-1085(327)	2012	30-1

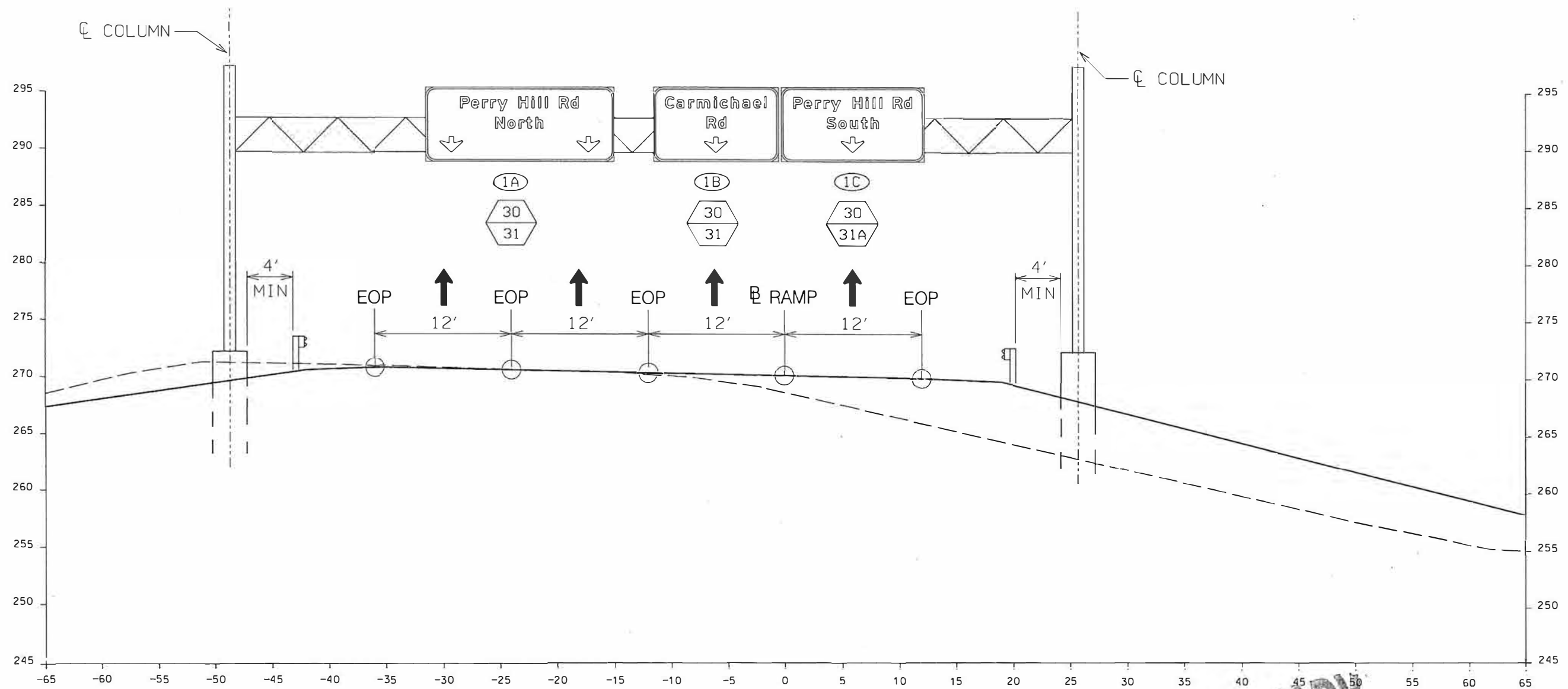

OHSB-1 RELOCATED EXIT RAMP A
STA 105+00

PRELIMINARY
NOT TO BE USED FOR
CONSTRUCTION

REQUIRED TOTAL PANEL AREA: 260.0 SQ FT
DESIGN WIND VELOCITY: 80 MPH

SIGNING LEGEND	
(1X)	SIGN NUMBER
50H	SIGN LAYOUT SHEET
74L	SIGN FACE DETAIL SHEET

FIGURE 15

RESPONSIBLE PE:	SUPERVISOR: <i>PLB</i>	DESIGNER: <i>RMS</i>	PLAN SUBMITTAL	ALABAMA DEPARTMENT OF TRANSPORTATION ROADWAY DESIGN SECTION D1	HORIZ SCALE (FEET)	SHEET TITLE	ROUTE
DATE:	DATE: <i>03/09/12</i>	DATE: <i>2/27/12</i>	CONSTRUCTION			SIGNING CROSS SECTIONS	I-85

**EXAMPLES,
PHOTOS,
ETC**

Typical Ground Mounted Signs Required For Rural Interchanges



To Be Placed 1 Mile In Advance Of Gore



To Be Placed 1/2 Mile In Advance Of Gore



To Be Placed At Gore

Typical Ground Mounted Signs Required For Rural Interchanges



Destination Sign To Be Placed In Advance Of Ramp Terminals

Exit Gore Sign To Be Placed In Gore Between Ramp And Mainline



Destination Sign To Be Placed On Cross Road With Directional Assembly



AN EXAMPLE OF A BUTTERFLY MOUNTED SIGN



AN EXAMPLE OF A CANTILEVER MOUNTED SIGN PLACED
IN ADVANCE OF AN OUTSIDE LANE DROP



AN EXAMPLE OF AN EXIT DIRECTION SIGN FOR A
DOUBLE EXIT RAMP



AN EXAMPLE OF EXIT DIRECTION SIGNS AT
AN EXIT RAMP SPLIT



AN EXAMPLE OF AN ARROW PER LANE SIGN



AN EXAMPLE OF A DIAGRAMMATIC SIGN

(NOT PREFERRED)



HERE IS AN EXAMPLE OF INCONSISTENT SIGN SIZES



NOTICE THE INCORRECT SIZE OF THE STATE ROUTE SHIELD
SHOWN ON THIS ADVANCE GUIDE SIGN



THIS SIGN IS NOT VERY VISIBLE AS A GROUND MOUNTED INSTALLATION. AN OVERHEAD INSTALLATION WITH A PROPER DESIGNED PANEL WOULD BE MORE APPROPRIATE FOR THIS OUTSIDE LANE DROP.