

Alabama Handbook for

Erosion Control, Sediment Control and Stormwater Management on Construction Sites and Urban Areas (The Blue Book)

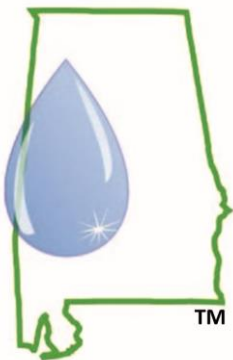

Volume 1

Developing Plans and Designing
Best Management Practices

2022

Alabama Soil and Water Conservation Committee
Montgomery, Alabama

Foreword

A concerted effort has been made to make the July 2022 Blue Book an accurate and comprehensive handbook useful to those involved in the technical aspects associated with land disturbances in Alabama.

The Blue Book is available primarily as an electronic version from the following web site:

<https://alabamasoilandwater.gov/alese/>

It may be viewed and printed without a charge.

Hardcopies of the Blue Book or a CD may be purchased from the Alabama Chapter of the Soil and Water Conservation Society through the Jefferson County Soil and Water Conservation Foundation. Order forms are available on the website listed for viewing the Blue Book.

Constructive comments on the contents of the 2022 Blue Book should be provided in writing to the Alabama Soil and Water Conservation Committee at the following address:

Alabama Soil and Water Conservation Committee
P. O. Box 304880
Montgomery, AL 36130-4800

All programs and services of the federal, state, and local agencies and organizations that cooperated in the preparation of the handbook are available on a nondiscriminatory basis without regard to race, color, national origin, religion, sex, age, marital status, handicap or disability.

Acknowledgements

This 2022 Blue Book update is a product of a partnership project between Alabama Soil and Water Conservation Committee, Alabama Chapter of the Soil and Water Conservation Society, Alabama Association of Conservation Districts, Alabama Department of Environmental Management, Alabama Department of Transportation, Associated General Contractors of Alabama, Home Builders Association of Alabama, the USDA - Natural Resources Conservation Service, Stormwater Research Facility at Auburn University, Auburn University, and Alabama Cooperative Extension System.

Steering Committee – 2022

Dr. William E. Puckett, Executive Director
Alabama Soil and Water Conservation Committee, Montgomery, Alabama

Jack Wadsworth, Chairman, Urban Conservation Committee
Alabama Association of Conservation Districts, Autauga County, Alabama

Louise Brown, Education Specialist
Home Builders Association of Alabama, Montgomery, Alabama

Eve Brantley, Director
Auburn University Water Resources Center, Auburn, Alabama

Barry Fagan, Vice President – Environment & Infrastructure
Volkert, Inc., Montgomery, Alabama

Wade Henry, Assistant State Design Engineer, Final Design Division,
Alabama Department of Transportation, Montgomery, Alabama

James Carlson, Chief, Stormwater Management Branch of the Water Division
Alabama Department of Environmental Management, Montgomery, Alabama

Jeff Rodgers, President of AGC Services, AGC Birmingham Chapter Headquarters
Alabama Associated General Contractors, Birmingham, Alabama

Shannon McGlynn, Senior Environmental Scientist, NPS Unit
Alabama Department of Environmental Management, Montgomery, Alabama

Jesse Joiner, President
Alabama Chapter of the Soil and Water Conservation Society

Vernon Abney, State Conservation Engineer
USDA-Natural Resources Conservation Service, Auburn, Alabama

Mike Perez, Assistant Professor, Auburn University, Department of Civil and Environmental Engineering, and Director, Stormwater Research Facility at Auburn University

Mike Shelton, Coastal Training Program Coordinator, Weeks Bay National Estuarine Reserve

Handbook Authors – 2002 through present

Jim Baier, Assistant Professor-Biosystems Engineering
Auburn University, Auburn, Alabama (no longer with Auburn University)

Eve Brantley, Director of the Auburn University Water Resources Center, Auburn, Alabama

Christopher Davis, State Soil Scientist
USDA – Natural Resources Conservation Service, Auburn, Alabama

H. Jeff Holloway, Resources Engineer
USDA-Natural Resources Conservation Service, Oxford, Alabama (now works in Georgia with FERC)

Richard Hulcher, Chief, Office of Field Services
Alabama Department of Environmental Management, Montgomery, Alabama

Charlene M. LeBlue, Associate Professor
School of Architecture, Auburn University, Auburn, Alabama

Tim Logiotatos, Environmental Engineer
City of Auburn, Auburn, Alabama (no longer works with City of Auburn)

Eddie R. Jolley, Conservation Agronomist
USDA-Natural Resources Conservation Service, Auburn, Alabama (retired from NRCS)

Jerry L. Johnson, State Staff Forester
USDA-Natural Resources Conservation Service, Auburn, Alabama (deceased)

Lawrence McGhee, State Soil Scientist
USDA-Natural Resources Conservation Service, Auburn, Alabama (retired from NRCS)

Earl L. Norton, E&SC Program Specialist
Alabama Chapter, Soil and Water Conservation Society, Auburn, Alabama

Perry L. Oakes, E&SC Program Coordinator
Alabama Chapter, Soil and Water Conservation Society, Auburn, Alabama

Teresa Paglione, Cultural Resources Specialist,
USDA-Natural Resources Conservation Service, Auburn, Alabama (retired from NRCS)

Kenneth M. Rogers, Conservation Agronomist
USDA-Natural Resources Conservation Service, Auburn, Alabama (retired from NRCS)

B. Dewayne Smith, Associate
Malcolm Pirnie, Inc., Auburn, Alabama (no longer with Malcolm Pirnie)

E. Don Surrency, Plant Materials Specialist
USDA-Natural Resources Conservation Service, Athens, Georgia (retired from NRCS)

Jeffery Thurmond, Wildlife Biologist
USDA-Natural Resources Conservation Service, Auburn, Alabama

Technical Advisors – 2014 through present

Tim Albritton, State Staff Forester
USDA-Natural Resources Conservation Service, Auburn, Alabama

Wesley Donald, PhD, Research Fellow IV,
Department of Civil and Environmental Engineering, Auburn University, Alabama

Barry Fagan, Vice President – Environment & Infrastructure
Volkert, Inc., Montgomery, Alabama

Charles H. Gilliam, Professor
Department of Horticulture, Auburn University, Auburn, Alabama (retired from Auburn)

Wade Henry, Assistant State Design Engineer, Preliminary Engineering Division,
Alabama Department of Transportation, Montgomery, Alabama

Wesley C. Zech, PhD, Professor
Department of Civil Engineering, Auburn University, Alabama (now at UAB)

Mike Perez, PhD, Assistant Professor
Department of Civil and Environmental Engineering, Auburn University, and Director
Stormwater Research Facility at Auburn University

AUTOCAD drawings provided by:

Jeff Dowdy, Civil Engineering Technician
Natural Resources Conservation Service, Auburn, Alabama (retired)

This Page Intentionally Left Blank

Table of Contents

Foreword	i
Acknowledgements	iii
Table of Contents	vii
Introduction and Summary of Changes	ix
Chapter 1: Erosion, Sedimentation and Stormwater Processes	1
Chapter 2: General Planning Concepts for Erosion Control, Sediment Control, and Stormwater Management	7
Chapter 3: Plan Preparation	45
Chapter 4: Best Management Practices Design	63
Site Preparation	
Construction Exit Pad (CEP)	65
Land Grading (LG)	69
Topsoiling (TSG)	73
Surface Stabilization	
Chemical Stabilization (CHS)	79
Dune Sand Fence (DSF)	81
Dune Vegetation Planting (DVP)	85
Dune Walkover (DW)	93
Dust Control (DC)	97
Erosion Control Blanket (ECB)	101
Groundskeeping (GK)	109
Mulching (MU)	115
Permanent Seeding (PS)	121
Preservation of Vegetation (PV)	131
Retaining Wall (RW)	141
Shrub, Vine and Groundcover Planting (SVG)	143
Sodding (SOD)	153
Temporary Seeding (TS)	159
Tree Planting on Disturbed Areas (TP)	165
Runoff Conveyance	
Check Dam (CD)	171
Diversion (DV)	179
Drop Structure (DS)	185
Grass Swale (GS)	189
Lined Swale (LS)	195
Outlet Protection (OP)	201

Riprap-lined Swale (RS).....	213
Subsurface Drain (SD).....	219
Temporary Slope Drain (TSD).....	225
Sediment Control	
Brush/Fabric Barrier (BFB).....	231
Filter Strip (FS).....	235
Floating Turbidity Barrier (FB).....	241
Flocculant.....	249
Inlet Protection (IP).....	255
Rock Filter Dam (RD).....	263
Sediment Barrier (SB).....	267
Sediment Basin (SBN).....	275
Stormwater Management	
Bioretention Area (BA).....	293
Porous Pavement (PP).....	303
Stormwater Detention Basin (SDB).....	307
Stream Protection	
Buffer Zone (BZ).....	315
Channel Stabilization (CS).....	319
Stream Diversion Channel (SDC).....	325
Streambank Protection (SP).....	331
Temporary Stream Crossing (TSC).....	343

Appendix (filed in either Volume I or Volume II) Note: The Appendix should be inserted by the user in the Handbook Volume that will make it most useful to the user.

Soils in Alabama	1
Instructions for Use of Web Soil Survey for Generating Engineering, Physical & Chemical Properties of Soil	11
AASHTO M 288	22
Glossary	23
References	40
CAD Drawings	44
Local Information	46

Introduction

The *Alabama Handbook for Erosion Control, Sediment Control and Stormwater Management on Construction Sites and Urban Areas* (The Blue Book) provides guidance for preventing or minimizing the related problems of erosion, sediment, and stormwater on construction sites and eroding urban areas in the State of Alabama. It provides a basis for developing sound plans to implement appropriate control measures, commonly referred to as Best Management Practices (BMPs). It can help users meet environmental and regulatory objectives.

The Blue Book recognizes that erosion and runoff are influenced by the combination of climate, topography, soils, vegetative cover, and the extent of land-disturbing activities. Because topography, soils, environmental conditions, and to a lesser extent local climate vary widely over the state, the application of the procedures and criteria in The Blue Book should be tailored to local site-specific conditions and user objectives.

Erosion at construction sites and the resulting sediment-laden, turbid stormwater runoff impact individuals, our communities, and the environment. Damages occur on-site and off-site if land, water, and related resources are degraded. Similar impacts may occur as a result of erosion in urban areas on non-construction sites.

The Alabama Soil and Water Conservation Committee, acting under authorities set forth in section 9-8-22 of the Code of Alabama 1975, printed the first edition of the Handbook in 1993. Its purpose was to aid land users, including developers, contractors, consultants, city, county and state planners and planning boards, other governmental officials, and homeowners in adequately addressing the soil erosion, sediment, and stormwater issues associated with land disturbing activities related to non-agricultural development. The First Revision of the Handbook was completed in 2002. It added Chapter 9, providing thirteen additional practices that were not outlined in the original Handbook.

The June 2003 Handbook update included all parts of the previous handbook but divided it into two volumes to make the contents more user-friendly. Additional practices were added to make the Handbook more comprehensive. Revision No. 1 dated January 2006 was made to add the Bioretention and Stream Diversion practices, to revise the procedure for determining the size of riprap for the Channel Stabilization practice and to correct several grammatical errors.

Revision No. 2 of March 2009 made significant changes including adding the concept of Low Impact Development and revising practices in the Sediment Control section.

Revision No. 3 of September 2014 made improvements by incorporating industry suggestions and further integrating the concepts of Low Impact Development to mesh with the new LID Handbook in Alabama. Some of the more significant changes include replacing exotic invasive species with native species in the Shrub, Vine and Groundcover Planting practice, modifying the specifications of the Class A Silt Fence in the Sediment Barrier practice, adding the practice Flocculant as a Sediment Control measure, and providing CAD drawings for several of the practices that were supported earlier with only figures.

Revision No. 4 of July 2018, corrected some misspellings, made changes to several practices based on recent research of The Auburn University Erosion and Sediment Control Test Facility, consolidated the Inlet Protection practices, revised the Erosion Control Blanket practice to be more in-line with industry guidelines, and incorporated more specific geotextile property requirements.

Since 2018, the Handbook has been commonly referred to as the Blue Book. This terminology is incorporated into the 2022 revision. This major revision No. 5 of July 2022 corrected some misspellings and made changes to several practices based on recent research of The Auburn University Stormwater Research Facility. Major changes occurred to the Sediment Barrier practice. A Summary of Changes since the 2018 Blue Book are included at the end of the introduction.

It is a goal of the Alabama Soil and Water Conservation Committee that we keep the Blue Book current with changing technology. Although we cannot use the Blue Book to identify and recommend specific products, we recognize that product development will continue and that over time we gain a better understanding of the effectiveness of practices and systems. We desire that the Blue Book framework accommodate, usually in a generic context, those products that are needed in Alabama and our understanding of how they should be used to efficiently protect our land and water resources.

As we look to the future, we urge those that make decisions affecting our land and water resources to voluntarily embrace sound technology, practice strong stewardship of our land and water resources, and encourage their colleagues to promote voluntary conservation efforts. Yes, regulations are necessary for several reasons, but a conservation ethic that recognizes that our natural resources should be protected during and after development puts the tasks of erosion control, sediment control and stormwater management in an important and positive context. Using this approach maximizes benefits to the citizens of Alabama and protects the State's precious environment.



Dr. William E. Puckett, Executive Director
Alabama Soil and Water Conservation Committee

Summary of Changes

Purpose: To outline significant changes since the 2018 Volume 1 Blue Book was published. (Minor edits and formatting changes are not listed).

Major Changes:

1. Chapter 4, Check Dam, page 174: Changed the recommendation of sod staple spacing for a Wattle Check Dam from 10-inch centers to approximately 6-inch centers on each side of the wattle.
2. Chapter 4, Drop Structure, page 186: In the General Section, indicated that a sand drainage diaphragm with a filter compatible outlet “is the best alternative” to an anti-seep collar.
3. Chapter 4, Drop Structure, page 187: Added Drainage Diaphragm to Figure DS-1.
4. Chapter 4, Drop Structure, page 188: Added Drainage Diaphragm to Figure DS-2.
5. Chapter 4, Lined Swale, page 195: Included tied concrete block mats as a material for lining.
6. Chapter 4, Subsurface Drain, throughout practice: Added coarse sand as part of the filtering medium to keep soil particles from migrating into the drainage system.
7. Chapter 4, Subsurface Drain, page 222: Added coarse sand to Figure SD-1.
8. Chapter 4, Subsurface Drain, page 223: Added coarse sand to Figure SD-2.
9. Chapter 4, Flocculant, pages 250-251: Moved the description of a sediment retention barrier to this practice and renamed it a “turbidity reduction barrier” and added that the netting for a turbidity reduction barrier should be a high-flow non-binding fabric.
10. Chapter 4, Inlet Protection, page 261: Changed the recommendation of sod staple spacing for a Wattle Inlet Protection from 10-inch centers to approximately 6-inch centers on each side of the wattle.
11. Chapter 4, Sediment Barrier, page 267: In the Practice Description, introduced the Design Storage Volume that should be more than the runoff volume.
12. Chapter 4, Sediment Barrier, pages 267-269: In the Planning Considerations, added recommendations for proper location and configuration, overtopping and dewatering device, when wire basket or reinforced fence should be used, and the preferred method of installation being the off-set installation.
13. Chapter 4, Sediment Barrier, deleted reference to a sediment retention barrier in this practice (see Flocculant).
14. Chapter 4, Sediment Barrier, page 269: Added that the $\frac{1}{4}$ or $\frac{1}{2}$ acre limitation per 100 feet of silt fence is a “general rule of thumb”. The silt fence should be designed to impound the design storm event. Guidance is provided on selection of the design storm event.
15. Chapter 4, Sediment Barrier: the old Table SB-2 Slope Limitations for Silt Fence has been deleted.
16. Chapter 4, Sediment Barrier, page 270: Added that equivalent backing or reinforcement is allowed for wire reinforcement if it is sewn in or physically attached to the silt fence fabric.
17. Chapter 4, Sediment Basin, page 279: Added a Minimum Standing Pool Depth to the Design Criteria
18. Chapter 4, Sediment Basin, page 287: Added Standing Pool to Figure SBN-6.
19. Chapter 4, Sediment Basin, page 288: Added Standing Pool in Step 3.
20. Chapter 4, deleted the practice Sediment Trap.
21. Chapter 4, Stormwater Detention Basin, page 311: Noted that a filter diaphragm should be preferred over an anti-seep collar and listed a reference for design.
22. Chapter 4, Stormwater Detention Basin, pages 312 - 314: Added Drainage Diaphragm to Figures SDB-1, 2, and 3.
23. Chapter 4, Streambank Protection, pages 333 and 336: Included tied concrete block mats as a measure for protection.

New Content:

1. Chapter 4, Erosion Control Blanket, page 101: In Planning Considerations added “When possible consider the use of wildlife friendly netting”.
2. Chapter 4, Groundskeeping, page 114: In the bullet related to paint, the term “painting equipment cleaning liquid” was added.
3. Chapter 4, Mulching, page 116 and 119: Added the sentence to consider the use of wildlife friendly netting.
4. Chapter 4, Sodding, page 156: Added the sentence to consider the use of wildlife friendly netting.
5. Chapter 4, Brush/Fabric Barrier, page 233: Added Figure BFB-1.
6. Chapter 4, Sediment Barrier, page 270: Added the section on Overflow Outlet and Dewatering.
7. Chapter 4, Sediment Barrier, page 272: Added Figure SB-5 for Type A Overlap.
8. Chapter 4, Sediment Basin, page 281: Added the standing pool elevation as the lower limit to the volume requirement.

Major Clarifications:

1. Chapter 4, Dune Vegetation Planting, page 86: Corrected the section name in Chapter 2 for the selection of plants.
2. Chapter 4, Erosion Control Blanket, page 103: Corrected the URL to ECTC documents.
3. Chapter 4, Groundskeeping, page 111: Added that Fueling and Servicing activities should be as far away as possible from Waters of the State and conveyances.
4. Chapter 4, Groundskeeping, page 111: Added that Mud Tracking cleanup should only be done using “dry” methods.
5. Chapter 4, Groundskeeping, pages 111-112: Clarified concrete truck washout containment.
6. Chapter 4, Groundskeeping, page 112: Added that waste containers should be as far away as possible from Waters of the State and conveyances.
7. Chapter 4, Permanent Seeding, page 124: Added footnote 1 to Table PS-1, “DO NOT USE Seeding Rates as part of a mixture unless shown as a mixture in this table”.
8. Chapter 4, Temporary Seeding, page 162: Added footnote 1 to Table TS-1, “DO NOT USE Seeding Rates as part of a mixture”.
9. Chapter 4, Check Dam, page 176: Modified Figure CD-8 to show geotextile underlayment.
10. Chapter 4, Check Dam, page 177: Modified Figure CD-9 to show geotextile underlayment.
11. Chapter 4, Lined Swale, pages 196-197: Clarified the Design Criteria for a concrete lined swale.
12. Chapter 4, Filter Strip, page 238: Added footnote 1 to Table FS-1, “DO NOT USE Seeding Rates as part of a mixture unless shown as a mixture in this table”.
13. Chapter 4, Flocculant, page 251: Clarified the first sentence in Design Criteria.
14. Chapter 4, Sediment Barrier, page 270: Deleted the statement that Type A silt fence has 3 times the flow rate as Type B silt fence.
15. Chapter 4, Sediment Basin, page 282: Added a filter diaphragm reference in the Basin Dewatering Section.
16. Chapter 4, Bioretention Area, page 293 and 301: Corrected the URL to the LID Handbook for Alabama.

Chapter 1

Erosion, Sedimentation and Stormwater Processes

This chapter is included to provide basic information related to the processes referred to as erosion, sedimentation, and stormwater management. If in-depth information is needed on these subjects, other references should be used.

Erosion and Sedimentation Processes

Erosion

Erosion is the process by which the land surface is worn away by the action of water, wind, ice or gravity. Water-related erosion is the primary problem in the developing areas of Alabama and is the primary type of erosion that this handbook addresses.

The Appalachian Plateau, Limestone Valleys and Uplands, and Piedmont Plateau of Northern Alabama are all products of geologic uplift and extended erosion caused by natural forces. The Coastal Plain and the Blackland Prairie of Alabama represent the sedimentation and deposition product from millions of years of geologic erosion from the upland sources. With the exception of shorelines and stream channels where erosion may be rapid and catastrophic, geologic erosion occurs at very slow rates. This natural erosion process, which has taken place over millions of years, has probably occurred at rates comparable to erosion on our current forests.

In contrast to geologic erosion, the erosion accelerated by the disturbances of humans, through agriculture and non-agricultural uses of the land, has caused several inches of erosion over the last 100 to 150 years, a comparatively short period. Thus, "accelerated erosion" can be very significant and potentially create related adverse impacts. Accelerated erosion occurs in non-agricultural areas where developing sites are either poorly planned or the plans that appear adequate are not installed and maintained properly.

To understand erosion caused by water, it is helpful to think of the erosive action of water as the effects of the energy developed by rain as it falls or as the energy derived from water's motion as it runs across the land surface. Both falling rain and flowing water, typically referred to as stormwater, perform work in detaching and moving soil particles, but their actions are different. The force of falling rain is applied vertically. The force of flowing water is applied mostly horizontally. The energy of raindrops falling on bare soils detaches soil particles. Water flowing over exposed soil picks up detached soil particles. As the velocity of flowing water increases, additional soil particles are detached and transported. Flowing water concentrates because of surface irregularities. If not prevented, these flows will create small channels, or rills, and eventually larger channels, or gullies of varying widths and depths. If the volume and velocity of storm runoff leaving a disturbed site increases because of the activities on the site, it is likely to cause additional erosion of streambanks and possibly floodplains beyond the rate of geologic erosion.

Although not as prominent in the Southeast as erosion caused by water, wind erosion can cause on-site health and safety problems and is a source of fugitive dust.

Sedimentation and Turbidity

Sedimentation is the process that describes soil particles settling out of suspension as the velocity of water decreases. The larger and heavier particles (gravel and sand) settle out more rapidly than silt and clay particles. The silt and clay particles are easily transported and settle out very slowly. It is difficult, and perhaps impossible in some instances, to eliminate the transport of the clay and silt particles even with the most effective erosion control programs.

Turbidity occurs in conjunction with sedimentation. Turbidity, a cloudy, muddy condition in the water, occurs when eroded soil is suspended in the water (i.e. before it settles out). Turbid water can stress or kill fish by clogging their gills and making it hard for them to see food sources.

Factors Influencing Erosion

The erosion process is influenced primarily by climate, topography, soils, and vegetative cover. The following description of the factors is an overview adequate for this handbook, however it is recognized that this is a very complex subject and that there are many details not included.

Climate

Climate includes rainfall, temperature and wind. The frequency, intensity and duration of rainfall are the principal aspects of rainfall influencing the volume of runoff, erosion and sediment (potential) from a given area. As the volume and intensity of rainfall increase, the ability of water to detach and transport soil particles increases. When storms are frequent, intense, and of long duration, the

potential for erosion of bare soils is high. Temperature has a major influence on soil erosion. Frozen soils are relatively erosion resistant. However, bare soils with high moisture content are subject to uplift or "spew" by freezing action and are usually very easily eroded upon thawing. Wind contributes to the drying of soil and increases the need for irrigation for new plantings and for applying wind erosion control practices during periods of bare soils.

Topography

Topography includes the shape and slope characteristics of an area or watershed and influences the amount and duration of runoff. The longer the slope length and the steeper the slope gradient, the greater the potential for runoff, erosion and sediment delivery.

Soils

Soil factors include soil texture, soil structure, organic matter content and permeability. In addition, in many situations soil compaction is significant. These aspects greatly determine the erodibility of soil.

Soils containing high percentages of sand and silt are the most susceptible to detachment because they lack inherent cohesiveness characteristics. However, the high infiltration rates of sands either prevent or delay runoff except where overland flow is concentrated. Clearly, well-graded and well-drained sands are usually the least erodible soils in the context of sheet and rill erosion.

Clay and organic matter act as a binder to soil particles thus reducing erodibility. As the clay and organic matter content of soils increase, the erodibility decreases. But, while clays have a tendency to resist erosion, they are easily transported by water once detached.

Soils high in organic matter resist raindrop impact and the organic matter also increases the binding characteristics of the soil.

Sandy and silty soils on slopes are highly susceptible to gully erosion where flows concentrate because they lack inherent cohesiveness.

Small clay particles, referred to as colloids, resist the action of gravity and remain in suspension for long periods of time. Colloids are a potential major contributor to turbidity in receiving waters.

Vegetative Cover

Vegetative cover is an extremely important factor in reducing erosion at a site. Vegetative cover will:

- a. Absorb or dissipate energy of raindrops.
- b. Bind soil particles and prevent or reduce soil detachment by raindrops or overland flow.

- c. Slow velocity of runoff water.
- d. Increase the ability of a soil to absorb water.
- e. Remove subsurface water between rainfall events through the process of evapotranspiration.
- f. Reduce off-site fugitive dust.

By limiting the amount of vegetation disturbed and the exposure of soils to erosive elements, soil erosion can be greatly reduced.

Stormwater

Water flowing over the land during and immediately following a rainstorm is called stormwater runoff. The runoff passing a particular point is equal to the total amount of rainfall upstream of that point less the amounts of infiltration, transpiration, evaporation, surface storage and other losses. The amount of these losses is a function of climate, soils, geology, topography, vegetative cover and, impervious surfaces.

In an undeveloped area, stormwater runoff is managed by nature through the hydrologic cycle. The cycle begins with rainfall. Rain either stands where it falls and evaporates or it is absorbed into the ground near the surface, to feed trees and vegetation, ultimately to be returned to the atmosphere by transpiration; or it percolates deeply into the ground replenishing the groundwater supply. The remainder of the rainfall collects into rivulets. This collected runoff increases in quantity as it moves down the watershed, through drainageways, streams, reservoirs and to its ultimate destination, the river and then the sea. Evaporation from the sea surface begins the cycle again.

This simple explanation of the hydrologic cycle belies its complexity. Nature's inability to accommodate severe rainfalls without significant damage, even in undeveloped areas, is very apparent. Nature's stormwater management systems are not static but are constantly changing. Streams meander, banks erode, vegetation changes with the seasons, and lakes fill with sediment and eventually disappear. The stripping of ground and tree cover by fire can change an entire system forcing new natural accommodations throughout the system.

The volume of stormwater runoff is governed primarily by infiltration characteristics and is related to the land use and its impervious surfaces, soil type, topography and vegetative cover. Thus, runoff is directly related to the percentage of the area covered by roofs, streets and other impervious surfaces. Water intercepted by vegetation and evaporated or transpired is lost from runoff. A small portion of the water that infiltrates into the soil and groundwater is delivered to the stream as delayed flow and does not contribute directly to peak stormwater runoff. Impervious surfaces normally contribute almost all of the total rain immediately to stormwater runoff.

There are 4 distinct yet interrelated effects of land use changes on the hydrology of an area:

1) changes in peak flow; 2) changes in total runoff; 3) changes in water quality; and 4) changes in the hydrologic amenities (Leopold, 1968). The hydrologic amenities are what might be called the appearance or the impression which the river, its channel and its valleys, leaves with the observer.

Of all land use changes affecting the hydrology of an area, urbanization is the most forceful. As an area becomes urbanized, the peak rate of runoff and volume of runoff increase. These effects are caused by: 1) a reduction in the opportunity for infiltration, evaporation, transpiration and depression storage; 2) an increase in the amount of imperviousness; 3) modification of the surface drainage pattern, including the associated development of stormwater management facilities.

Summary of Hazards Associated with Land Development

On-site

Land development clearly increases potential erosion and sediment hazards on-site by removing vegetative cover, developing cuts and fills that are more susceptible to erosion than the previously undisturbed soils and changing water conveyance routes. More subtle changes related to erosion and sediment include soil compaction (both planned and unplanned), longer slopes and more and faster stormwater runoff.

Off-site

Land development, in most instances, has the following potential effects off-site both during and following the development phase and clearly reflect the impacts of changed use of the land on stormwater:

- Higher peak flows of storm runoff if not modified by planned measures.
- Increased volumes of storm runoff.
- Increased loads of sediment and other pollutants associated with the site unless prevented or minimized by planned measures.

Other potential off-site effects include increased flooding, accelerated erosion of stream systems, increased sediment deposition in lakes, streams, and floodplains, and adversely impacting the aquatic communities associated with the lakes, streams and floodplains.

Overall

Each progression toward more intensive land use tends to disrupt the ongoing natural processes which protect and preserve water quantity and water quality.

Therefore, to ensure future protection of water resources, it is imperative that land uses be managed in a responsible way.

As we reflect on the processes and the potential impact, we should recognize the importance of sound site planning, timely and proper installation of the measures planned and the need for long-term maintenance of measures that sustain site stabilization. If the best available technology is used for planning, design, installation and maintenance of erosion and sediment control and stormwater management the impacts of land development will be minimized. Other chapters of the Blue Book present relevant planning considerations, design criteria and installation and maintenance information.

Chapter 2

General Planning Concepts for Erosion Control, Sediment Control and Stormwater Management

This chapter provides important concepts and other selected information that is important for qualified design professionals to know about various aspects of erosion control, sediment control, and stormwater management. It is believed that the contents will, at a minimum, cause qualified design professionals to recognize when other professionals may need to be involved. A qualified design professional should recognize that planning involves several disciplines and that each discipline has a body of in-depth knowledge that is important and needed on complex sites. Although often discussed separately, erosion control, sediment control, and stormwater management are interrelated, and the planning and design process must include an interdisciplinary approach towards practices and measures that consider all three together.

The basic details of planning, including step-by-step procedures, are located in Chapter 3.

Potential Erosion and Sediment Problems Associated with Land Development

The principal effect land development activities have on the erosion process consists of exposing disturbed soils to raindrops and to stormwater runoff. Shaping of land for construction or development affects physical properties of the soil, onsite drainage, stormwater runoff patterns, and eventually, off-site stream characteristics and functions. Adverse effects of erosion and sedimentation include impacts to soil, water quantity, water quality, and the aquatic ecosystem. Potential hazards associated with development include the following items.

1. An increase in developed areas exposed to stormwater runoff and soil erosion.
2. Increased volumes of stormwater runoff, accelerated soil erosion and sediment yield and higher peak flows caused by:
 - a. Removal of existing protective vegetative cover.
 - b. Exposure of underlying soil more erodible than original soil surface.

- c. Reduced capacity of exposed soils to absorb rainfall due to compaction caused by heavy equipment or crustation caused by rainfall energy.
 - d. Enlarged drainage areas caused by grading operations, diversions and street construction.
 - e. Prolonged exposure of unprotected disturbed areas due to scheduling problems and/or delayed construction.
 - f. Shortened times of concentration of surface runoff caused by altering slope steepness, slope length, and surface roughness and through installation of “improved” storm drainage facilities.
 - g. Increased impervious surfaces associated with the construction of streets, buildings, sidewalks, paved driveways, and parking lot.
3. Creation of aspects facing south and west that may hinder plant growth due to adverse temperature and moisture conditions.
 4. Exposure of subsurface materials which are rocky, acid, droughty or otherwise, unfavorable to the establishment and maintenance of vegetation.

Erosion and Sediment Control

A wide array of practices and measures are used for erosion and sediment control. Most of the practices and measures have application over the State and only a few, such as those practices used for dune stabilization, have use in a small geographical area.

There are numerous simple concepts that can provide an effective framework for minimizing erosion on a construction site and reducing delivery of sediment off of the site.

- Minimize the area disturbed by leaving existing vegetation that does not have to be removed.
- Minimize the period of bare ground by shortening construction periods and staging a project when possible.
- Sequence installation in a manner that supports shortened construction periods and permits the scheduling of temporary and permanent seeding when the practices can be most effective.
- Use sediment and turbidity control measures that minimize sediment and turbid water from leaving the disturbed site.

- Plan appropriate erosion control for all kinds of erosion that may occur depending upon specific site conditions.
- Prioritize stabilization of cut and fill slopes.
- Prioritize stabilization of sites that are transected by streams or are in close proximity to streams and/or reservoirs.
- Cover exposed soil with vegetation at every opportunity.
- Prevent sediment from leaving a construction site at entrance/exits during muddy periods.
- Regularly inspect and maintain practices to ensure their effectiveness.

Potential Stormwater Problems Associated with Land Development

All forms of land use affect water quality. In an undeveloped area, many ongoing physical, chemical, and biological processes interact to recycle most of the materials found in the runoff. As the human land use intensifies, these processes are disrupted. Man's activities add materials to the land surface (pesticides, fertilizers, animal wastes, oil, grease, heavy metals, etc.). These materials are then washed off by the rainfall and runoff; thereby, increasing the pollutant load carried to receiving waters by stormwater runoff.

Of primary importance to water quality is the "first flush". This term describes the washing action that stormwater has on accumulated pollutants in the watershed. In the early stages of runoff, the land surfaces, especially impervious surfaces such as streets and parking areas, are flushed clean by the stormwater. This flushing creates a shock loading of pollutants. Extensive studies in Florida have determined that the first flush equates to the first 1" of runoff which carries 90% of the pollution load from a storm (USGS, 1984). More recently, research has identified that the first ½", of runoff provides the first flush in some instances while other research has determined that runoff in excess of 1", including cut/fill areas associated with construction, may be more realistic. It is proper to say at this time that the amount of runoff that creates the "first flush" depends on several factors, including the activity, inherent site conditions, and pollutants. Treatment of the first flush, whatever the runoff amount, will help ensure that the adverse water quality effects of stormwater are minimized.

Finally, the value of the hydrologic environment as an amenity is primarily affected by three factors: ability of the stream to effectively transport water and sediment, the accumulation of trash, and the disruption of the stream community. Urban stream channels are impacted by increased stormwater volume and energy. These channels tend to have unstable and unvegetated banks, scoured or unconsolidated beds, and unusual accumulations of sediment and debris. These effects impair the effectiveness of stream functions and can lead to landscape changes, threatened or impaired infrastructure (roads, bridges, utilities, etc.), and increased flooding

throughout a community, Not only can urbanization effects on streams impact the landscape, but together with the accumulation of trash within the channel and across the floodplain (cans, lumber scraps, lawn clippings, concrete, wire, etc.), these all severely impact the stream and receiving waters. These factors disrupt the natural balance in the streams' biota resulting from the addition of nutrients, organics, and sediment. These disruptions increase algal growth and turbidity, lower the oxygen content of the water, and thereby change the biological character of the stream and receiving waters.

In summary, each progression toward more intensive land use tends to disrupt the ongoing natural processes which protect and preserve water quality. Therefore, to ensure future sustainability of water resources, it is imperative that land uses be managed in a responsible way.

What is Stormwater Management?

Historically, urbanization has resulted in the development of stormwater management systems to reduce flooding and provide safe throughfares and living conditions for a community. Such stormwater management systems are designed with a narrow focus for safety and convenience without recognition of other impacts. Therefore, no matter how intense a rainfall event or its duration, the conventional stormwater system is designed to remove stormwater runoff in the shortest possible time. In other words, conventional stormwater management is concerned with only the quantitative effects of runoff.

As the understanding of stormwater processes has grown and stormwater management technologies have improved, modern stormwater management can be far more comprehensive. An effective program involves the implementation of actions to control water within its hydrologic cycle with the objectives of providing: (1) flood control; (2) nonpoint source pollution control; and (3) off-site erosion control, all while balancing the need to provide safe living conditions within a community. Stormwater management applies to rural and urban areas alike; however, the techniques presented in this manual are most relevant to urban or urbanizing situations.

To accomplish the three objectives of stormwater management, it is necessary to ensure that the volume, rate, timing and pollutant load of runoff after development are similar to that which occurred prior to development. The approach suggested in this manual is to minimize the adverse impacts of stormwater through a coordinated system of source controls. Source controls emphasize the prevention and reduction of nonpoint pollution and excess stormwater flow before it ever reaches a collection system or receiving waters. Typical control strategies and management criteria to accomplish the objectives of stormwater management are discussed below.

Flood Control

This has been the most common goal of local stormwater management programs. The property damage, safety hazards, and inconvenience which can result from increased stream flooding in urbanizing watersheds usually get wide public

attention and urgent demands for government action. Two levels of drainage systems must be considered in developing a management strategy for flood control: the primary drainage system and the major drainage system.

The primary drainage system consists of the street gutters and ditches, storm sewers, culverts, and open channels which are designed to prevent inconvenience and minor property damages from relatively frequent storm events. Of course, the most effective strategy for flood control at this level is to plan and design the primary drainage system adequately in advance, keeping in mind the future development potential of the drainage area. Unfortunately, many existing drainage systems were designed on a piecemeal, “as needed” basis with little regard for future development. The capacity of such systems often becomes severely overwhelmed as development progresses throughout a watershed area, resulting in frequent minor flooding, impacts to infrastructures, and property damages.

One strategy for dealing with this problem is to replace or modify elements of the primary drainage system to provide the required capacity. This option is often expensive and does not control the source of the problem. However, this may be the only feasible method of correcting existing problems. To prevent future problems, an alternative strategy may be employed. Persons wishing to undertake new development may be required to control runoff from their sites in a manner which will not adversely affect the downstream drainage system. This control is usually accomplished through stormwater detention criteria, low impact development practices, and green infrastructure.

Typical detention criteria will specify that stormwater runoff from a new development must be controlled so that the post-development peak runoff rate does not exceed the pre-development peak rate for some specific frequency design storm or range of design storm events. In many localities, a 10-year design storm is specified to preserve the effectiveness of downstream drainage structures which were originally designed to pass a 10-year pre-development storm. Other localities require that larger storms (i.e., 50-100 year events) must be detained and released at a controlled rate to reduce the downstream impacts of major storms.

It should be kept in mind that the larger the storm event which is required to be controlled and the slower the allowable release rate, the greater the storage volume which will be required in the detention facility.

The major drainage system comes into play when the capacity of the primary drainage system is exceeded.

This major system consists of the flood plains and surface flow routes which water will follow during major storms. The most effective strategy for dealing with flooding at this level is to ensure that stormwater has a route to follow which will not cause major property damage or loss of life. To implement this strategy, flood plain ordinances, zoning regulations, or other land use controls should be used to restrict flood plain development. In areas where development has already encroached on the flood plain, landowners should be encouraged to purchase flood insurance, if appropriate.

Nonpoint Source Pollution Control (NPS Control)

Pollutants which are washed from the land surface by stormwater runoff and carried into the streams, rivers, and lakes are recognized as major contributors to water quality degradation in urban and urbanizing watersheds. The goal of controlling this problem is not new and nonpoint source pollution control receives high priority in many watersheds which feed public water supplies or recreation reservoirs; however, this goal should be addressed in all local stormwater management programs.

In urban areas, most of the stormwater practices which are used to control urbanized runoff may also be adapted for use as best management practices for nonpoint source pollution control. The design criteria of these practices for this purpose, however, are often different. The primary design strategy for pollution removal is to maximize the detention time of captured runoff and to infiltrate as much of the urban runoff as practical. It is believed that basin drawdown times between 30-40 hours will result in significant pollutant removal. The required storage volume of detention facilities can be tied to a first flush capture (i.e., the initial 0.1" to 1" of runoff).

Off-Site Erosion Control

This goal must be addressed in all local stormwater management programs. The strategies for dealing with this problem are similar to those for flood control. The major difference is in the frequency of the storm which must be controlled.

Studies have shown that most natural stream channels are formed with a bankfull capacity to pass runoff from a storm with a 1.5 to 2-year recurrence interval. As upstream development occurs, the volume and velocity of flow from these relatively frequent storms increase. Even smaller storms with less than 1-year recurrence intervals begin to cause streams to become overwhelmed and/or flood.

Stream channels are often subject to a 3 to 5-fold increase in the frequency of bankfull flows in a typical urbanizing watershed. This increase in volume and velocity of flow paired with the increased flooding frequency places a stress on the channel to adjust its shape and alignment to accommodate the increased flow.

Unfortunately, this adjustment takes place in a very short period (relative to natural processes) and the transition can be extensive and catastrophic. Meandering stream channels which were once parabolic in shape and covered with vegetation typically become straight, wide rectangular channels with barren vertical banks. This process of channel erosion often causes significant property damage, and the resulting sediment which is generated is transported downstream, further contributing to channel degradation.

An old strategy for managing this problem is to increase the carrying capacity and stability of affected streams through channel modifications (i.e., straightening, widening, lining with non-erodible material, etc.). Modifications to natural, continuous flowing streams, however, can be the subject of intense local controversy and requires special permits or permissions from regulating entities such as Army Corps of Engineers, Environmental Protection Agency (EPA), Federal Emergency Management Agency (FEMA), and others. Innovations based

on natural stream hydrology concepts are often more economically sound because they restore or maintain stream functions in a manner that is more sustainable than previously employed practices. Maintenance of such innovative practices are usually more cost- and time-effective. Natural Stream Restoration technologies are gaining favor and should be considered because of their beneficial effects to a community as well as on the aquatic environment.

Wherever modifications to natural flowing streams are being considered, extreme care must be taken to weigh the benefits of such modifications against the cost and the concerns of the local citizens. Where channel modifications are necessary, an attempt must be made to incorporate measures which will minimize adverse impacts to fish, wildlife, and the aesthetic quality of the stream.

On-site stormwater detention criteria for new development projects can also be an effective strategy for preventing future increases in stream impacts. However, such criteria should be tied to more frequent storm events than typical flood control criteria. Maintaining the pre-development peak runoff rate from a 10-year storm, for example, will probably not effectively reduce downstream erosion since the majority of storm events will pass right through the detention system unimpeded.

For example, the minimum state or local stormwater management criteria could be tied to a 2-year storm event. Receiving channels would then be capable of passing a 2-year storm without flooding or erosion after development of the site or stormwater would be detained on the site so that the pre-development peak flow rate from a 2-year storm is not exceeded after development. While flows from larger, less frequent storm events may cause erosion problems downstream, it is felt that because such events will occur less often, streams will have more time to recover and re-stabilize themselves.

Local stormwater detention criteria can be made more restrictive by requiring that storms larger than a 2-year event be detained. However, the allowable release rate should be tied to the actual carrying capacity of the receiving stream or the 2-year pre-development peak runoff rate.

Multiple-Purpose Criteria for a Detention Basin

Stormwater management criteria for flood control, erosion control, and pollution control are not necessarily mutually exclusive. In many cases, stormwater can be managed to accomplish all three goals simultaneously. For example, a stormwater detention basin can be designed as a multipurpose structure by incorporating different release rates at different stages (storage elevations).

The first stage is designed to capture an initial volume of runoff (i.e., the first flush) and release it very slowly through a subsurface drainage system. The second stage begins with an orifice cut in the riser pipe which has the capacity to pass stormwater runoff at a 2-year pre-development rate when water elevation reaches the top of the riser. The purpose of this stage would be to control downstream channel erosion from frequent storms. The top of the riser pipe could serve as the outlet for the third stage and may be designed to pass a 10-year storm at a pre-development rate for moderate flood protection downstream. The emergency spillway should be designed to pass at least the 100-year storm. While such a multi-

purpose design may not be feasible for all detention systems, there are often innovative approaches which can be taken to satisfy two or more local stormwater management goals.

Flexibility

Flexibility is extremely important in stormwater management programs. Each development project has a unique set of conditions and circumstances and a different potential for affecting the downstream drainage system.

Criteria which may be perfectly applicable to one project may be totally unsuitable for another. For example, requiring stormwater detention for flood control may be highly applicable to projects constructed in the upper reaches of a watershed, but may be unnecessary or even undesirable for new projects constructed near the outlet of the watershed.

A qualified design professional should be given an opportunity to design a drainage system which contributes to the achievement of established local stormwater management goals in the most cost-effective manner. To accomplish this, each project must be considered on an individual basis.

Principles of Stormwater Management

It is much more efficient and cost-effective to prevent problems than to attempt to correct problems after the fact. Sound land use planning decisions based on the site planning principles are essential as the first, and perhaps the most important, step in managing stormwater related problems. All new development plans (e.g., subdivisions, shopping centers, industrial parks, office centers, etc.) and redevelopment plans should include a comprehensive stormwater management system.

Every piece of land is part of a larger watershed. A stormwater management system for each development project should be based on and compliment a watershed-wide management plan.

Optimum design of the stormwater management system should mimic (and use) the features and functions of the natural drainage system which is largely capital, energy and maintenance cost free. Every site contains natural features which contribute to the management of stormwater under the existing conditions. Depending upon the site, existing features such as natural drainageways, depressions, wetlands, floodplains, highly permeable soils, and vegetation provide natural infiltration, help control the velocity of runoff, extend the time of concentration, filter sediments and other pollutants, and recycle nutrients. Each development plan should carefully map and identify the existing natural system. “Natural” engineering techniques should be used to preserve and enhance the natural features and processes of a site and to maximize the economic and environmental benefits. Engineering design can and should be used to improve the effectiveness of natural systems, rather than negate, replace, or ignore them.

The volume, rate, timing and pollutant load of stormwater after development should closely approximate the conditions which occurred before development. To accomplish these objectives two overall concepts must be considered: (1) the perviousness of the site should be maintained to the greatest extent possible; and (2) the rate of runoff should be slowed. Preference should be given to stormwater management systems which use measures that maintain vegetative and permeable land cover and include on-site storage mechanisms. These systems will promote infiltration, filtering, and slowing of the runoff.

The on-site storage of stormwater should be maximized. Provision for storage can reduce peak runoff rates; aid in groundwater recharge; provide settling of pollutants; lower the probability of downstream flooding, stream erosion and sedimentation; and provide water for other beneficial uses. Stormwater runoff should never be discharged directly into surface or ground waters. Runoff should be routed over a longer distance, through grassed waterways, wetlands, vegetated buffers and other works designed to increase overland flow. These systems provide time for increased infiltration and evaporation, allow suspended solids to settle, and remove pollutants before they are introduced to waters of the State.

Stormwater management systems, especially those emphasizing vegetative practices, should be planned, constructed, and stabilized in advance of the facilities that will discharge into them. This principle is frequently ignored thereby causing unnecessary off-site impacts, extra maintenance, re-working of grades, re-vegetation of slopes and grassed waterways, and extra expense to the developer. However, it is important to note that vegetation considerations should be made. Temporary vegetative cover may be implemented during times of disturbance while permanent landscape vegetative cover is only established after final site stabilization occurs. The stormwater management system, including erosion and sedimentation controls, should be constructed, and stabilized at the start of site disturbance and construction activities.

The stormwater management system must be designed beginning with the outlet or point of outflow from the project. The downstream conveyance system should be evaluated to ensure that it contains sufficient capacity to accept the design discharge without adverse downstream impacts such as flooding, streambank erosion and sedimentation. It may be necessary to stabilize the downstream conveyance system, especially near the stormwater system outlet. A common problem is a restricted outlet which causes stormwater to back up and exceed the storage capacity of the collection and treatment system resulting in temporary upstream flooding. This may lead to hydraulic failure of the stormwater management system causing re-suspension of the pollutants and/or expensive repairs to damaged structures or property. In such circumstances it is advisable to use more than one outlet or to increase the on-site storage volume.

Stormwater is a component of the total water resources which should not be casually discarded but used to replenish those resources. Stormwater represents a potential resource out of place, with its location determining whether it is a liability or an asset. Given the water quantity and quality problems and challenges facing Alabama, it is imperative that stormwater is considered to be an asset. Treated stormwater has a great potential for providing many beneficial uses such as irrigation (farm, lawn, parks, golf courses, etc.), recreational lakes, groundwater

recharge, industrial cooling and process water, and other non-potable domestic uses.

Whenever practical, multiple use temporary storage basins should be an integral component of the stormwater management system. All too often, storage facilities planned as part of the system are conventional, unimaginative ponds which are aesthetically unpleasing. Recreational areas (e.g., ball fields, tennis courts, volleyball courts, etc.), greenbelt areas, neighborhood parks, and even parking facilities provide excellent settings for the temporary storage of stormwater. Such areas are not usually in use during periods of precipitation and the ponding of stormwater for short durations does not seriously impede their primary functions. Storage areas should be designed with sinuous shorelines. Shorelines which are sinuous rather than straight increase the length of the shoreline. The increased shoreline also provides more space for the growth of shoreline vegetation, thus providing for greater pollutant filtering and for increased and diversified aquatic habitat.

Vegetated buffer strips should be retained in their natural state or created along the banks of all water bodies. Vegetated buffers prevent erosion, trap sediment, filter runoff, provide public access, enhance the site amenities, and function as a floodplain during periods of increased flow. They also provide a pervious strip along a shoreline which can accept sheet flow from developed areas and help minimize the adverse impacts of untreated stormwater.

The stormwater management system must receive regular maintenance. Failure to provide proper maintenance reduces the pollutant removal efficiency of the system and reduces the system's hydraulic capacity. Lack of maintenance, especially to vegetative systems which may require revegetating, can increase the pollutant load of stormwater discharges. The key to effective maintenance is the clear assignment of responsibilities to an established agency (local government) or organization (homeowners association) and a regular schedule of inspections to determine maintenance needs. In addition, stormwater system designers should find ways to make their systems as simple, natural and maintenance free as possible.

Green Infrastructure / Low Impact Development

Green Infrastructure (GI) and Low Impact Development (LID) are often used interchangeably. Green Infrastructure is defined as the range of measures that use plant or soil systems, permeable pavement or other permeable surfaces or substrates, stormwater harvest and reuse, or landscaping features to store, infiltrate, or evapotranspire stormwater and reduce flows to stormwater systems and surface waters. Green infrastructure is a cost-effective, resilient approach to managing wet weather impacts that provides many community benefits. While single-purpose gray stormwater infrastructure—conventional piped drainage and water treatment systems—is designed to move urban stormwater away from the built environment, green infrastructure reduces and treats stormwater at its source while delivering environmental, social, and economic benefits. Likewise, Low Impact Development or LID is “an interdisciplinary systematic approach to stormwater management that, when planned, designed, constructed, and maintained appropriately, can result

in improved stormwater quality, improved health of local water bodies, reduced flooding, increased groundwater recharge, attractive landscapes, wildlife habitat benefits, and improved quality of life” (LID Handbook for the State of Alabama). It is the practice of taking steps during design development to minimize changes to the hydrologic cycle (runoff and infiltration after a storm). LID strategies integrate green space, native landscaping, natural hydrologic functions, and various other techniques to generate less runoff from developed land (NRDC, Stormwater Strategies Report, 2001). These types of practices encourage infiltration and reduce the volume of stormwater discharged from the site. Many innovative site designs and stormwater management practices are grouped together under the heading of GI or LID, but true GI/LID strategies have certain key distinctions. These key distinctions of GI/LID include:

- Stormwater management at a local scale to minimize impact of development on the local watershed.
- Ecosystem-based. Design what you are building as a functional part of the ecosystem (not apart from it).
- Relies on advanced technologies more than conservation and growth management (Smart Growth plans).

GI/LID promotes hydrologic function at the lot level. It addresses stormwater through small, cost-effective landscape features referred to as integrated management practices (IMP) and stormwater control measures (SCM).

The Low Impact Development Handbook for the State of Alabama (LIDAL) is available online

(adem.alabama.gov/programs/water/waterforms/LIDHandbook.pdf).

Chapters on community planning and codes and ordinances are available through this resource.

Integrated Management Practices

The term IMP is used to denote controls that are integrated throughout the project and provide landscape amenity. Stormwater control measure or SCM is generally preferred instead of BMP due to its specificity to the field of stormwater and improved definition / description. The terms BMP and IMP are frequently used interchangeably. When Integrated Management Practices are linked together, they form *BMP trains* that address water quantity and water quality in succession. Such a train could be created by linking a rain barrel (overflow) to a rain garden, and the overflow drain of the rain garden to a constructed wetland.

History of LID

Many communities are turning to GI/LID to assist with stormwater management. Conventional solutions to handling stormwater runoff are not always compatible with community interests, or local, state, and federal water quality regulations. Prince George’s County, Maryland is known as the originator of the LID movement, and has pioneered many stormwater management practices and protective policies since the early 1980’s. The state of Wisconsin has also promoted LID since the late 1980’s, but dates to the early 1900’s in the origin of

sustainable products such as Milorganite, a fertilizer used in the golf course industry made from the byproduct of the Milwaukee sanitary sewer system.

What are the Key elements of GI/LID?

The key elements of GI/LID include:

- Conservation
- Small scale controls
- Customized site design
- Pollution prevention and education
- Directing runoff to natural areas

The preservation of native trees, understory vegetation and natural drainage processes are important in GI/LID development. They are enhanced by the small-scale controls on the lot level that mimic natural hydrology and processes. The customized design of these controls protects these processes and reduces pollutant loads and sends stormwater to areas of infiltration to facilitate ground water recharge. The network of small-scale GI/LID practices throughout the watershed have a major cumulative effect.

Planners/designers should consider using GI/LID because it enhances the local environment, protects public health, improves community livability and saves developers and local governments' money. There is often a 25% - 30% reduction in costs associated with site development, stormwater fees, and maintenance for residential developments that use GI/LID techniques (Low Impact Development Center). These savings are recognized through reductions in clearing, grading, pipes, ponds, inlets curbs, and paving.

GI/LID practices are applied to open space, roof tops, streetscapes, parking lots, sidewalks, and medians. The preservation of existing open space or the creation of new open space allows for large conservation areas where stormwater can soak into the ground and promote groundwater recharge. Roof top gardens or green roofs provide excellent insulation in warm climates and reduce heat island effects in urban environments. GI/LID promotes narrow streets and driveways, which reduce impervious surfaces as well as flooding and pollution from stormwater. There is typically no curb and gutter in GI/LID developments, and houses are usually closer to the street. Shared driveways are quite common.

Typical LID design components

Typical GI/LID design components to be considered include vegetation, pervious surfaces and bioretention systems. Vegetation removes water through evapotranspiration and assists in pollutant removal through nutrient cycling. Permeable surfaces allow stormwater to infiltrate into underlying soils promoting groundwater recharge and pollutant processing while reducing the volume of rainwater runoff. Bioretention systems detain water long enough for infiltration and pollution removal to occur. Bioretention systems may be designed as buffer strips, rain gardens, stormwater wetlands and grass swales.

Bioretention areas

Bioretention areas, also known as bioretention filters or cells, capture and temporarily store water. Water is conveyed to the treatment area as sheet flow. They can be designed to capture the first inch of rain and allow it to soak into the soil, watering the plants in the rain garden. Bioretention is designed to detain water just long enough for infiltration and pollution removal to occur, but not cause mosquito problems.

Rain gardens are residential practices that typically use native plants. Native plants are used because they are more drought-tolerant and require less maintenance. Pollutant removal is facilitated by microbes that live in the soil and interact with the plant roots. Stormwater drains from the rain garden within 24 – 48 hours eliminating concerns about mosquito habitat. Pathogens are left high and dry as water is absorbed.

Landscaping is critical to performance and function of a bioretention cell or rain garden. A diversity of plant types should be planted to replicate a natural ecosystem. Trees should be spaced at least 10 feet apart, hardwood mulch should be used, and plants should be tolerant of periodic cycles of inundation and drought.

Bioretention cells and rain gardens come in many shapes and sizes and can be used in commercial and residential landscapes, parking lots and medians, highway drainage, and on golf courses. The design can be tweaked to fit many uses. Basically, they take advantage of an existing low spot and are excavated and filled with amended soil to aid in the drainage process. There is an overflow drain that may be a perforated pipe or an existing stormwater outlet that has been raised to aid the temporary ponding of water.

Rain Barrels & Cisterns

Rain Barrels are small roof recapture systems that store residential rooftop runoff for localized use. Water collected in a rain barrel would normally flow through a gutter system or flows off a roof on to the ground possibly causing erosion. A rain barrel can save approximately 1,300 gallons of water during peak summer months of normal rainfall (Center for Watershed Protection, 2007). For every inch of rain that falls on a catchment area of 1,000 square feet, you can expect to collect approximately 600 gallons of rainwater. All systems should use covered barrels or cisterns that keep the water from accumulating leaves and other contaminants. Perhaps the simplest use of rainwater is to put a barrel under one of the gutter downspouts and use the water on sensitive indoor plants. Storing rainwater for garden and outdoor work use helps recharge groundwater naturally by slowing down and reducing stormwater runoff.

Cisterns work on the same principal as rain barrels but typically have a large storage capacity. Modern cisterns are manufactured of plastic and may or may not be completely enclosed. Rather they typically have a lid made of the same material as the cistern, which is removable by the user. In the USA, cisterns are predominately used for irrigation; however, some areas promote reuse of gray water (water from hand washing, dish washing, etc.) for toilet flushing.

Filter strips, grass swales and stormwater wetlands

Filter strips can be designed as landscape features within parking lots or other areas to collect flow from large impervious surfaces. Grass swales use grass or other vegetation to reduce runoff velocity and allow filtration, while high volume flows are channeled away safely. They function as alternatives to curb and gutter systems. Stormwater wetlands treat stormwater runoff by slowing stormwater and trapping pollutants.

Permeable Pavement

Interlocking pavers or porous paving materials allow air and water to pass through the surface providing groundwater recharge. “If used properly, permeable pavements can facilitate biodegradation of the oils from cars and trucks, help rainwater infiltrate soil, decrease urban heating, replenish groundwater, allow tree roots to breathe, and reduce total runoff, including the magnitude and frequency of flash flooding.” In his book, *Porous Pavements* (2005), Ferguson identifies nine categories of permeable pavement: decks, open-celled paving grids, open-graded aggregate, open-jointed paving blocks, plastic geocells, porous asphalt, pervious concrete, porous turf, and soft paving. It is the most popular form of structural post-construction BMP in Alabama.

Mixing Structural and Nonstructural Post-Construction BMPs

Mixing structural and nonstructural post-construction BMPs allow for the flexibility to create the proper BMP efficiency and cost for pollutant removal. The resulting configuration resembles a BMP Train, that is, a string of mix and match BMPs that are custom selected to a site’s pollutant situation. There are now several BMP calculators (typically Excel format) that will calculate the train’s efficiency and cost.

The benefits of GI/LID provide high level of water quality treatment. GI/LID tends to control volume of the first flush (first ½ inch to 1 inch) runoff. It is cost effective for developers and local governments and is aesthetically pleasing. GI/LID increases quality of water in local streams, rivers, lakes or bays. It also controls impacts to our natural ecosystems through selective BMP implementation. Instead of large investments in complex and costly centralized conveyance and treatment infrastructure, GI/LID allows for the integration of treatment and management measures into urban site features. This involves strategic placement of distributed lot-level controls that can be customized to more closely mimic a watershed’s hydrology and water quality regime. The result is a hydrologically functional landscape that generates less surface runoff, less pollution, less erosion, and less overall damage to lakes, streams, and coastal waters.

References

Low Impact Development Handbook for the State of Alabama. Alabama Cooperative Extension System.

<http://adem.alabama.gov/programs/water/waterforms/LIDHandbook.pdf>

Ferguson, Bruce K. 2005. *Porous Pavements*. Boca Raton; CRC Press.

Low Impact Development. November 2007.

<http://www.aces.edu/waterquality/nemo/lid.htm>

Stormwater Strategies--Community Responses to Runoff Pollution. Natural Resource Defense Council 2001 Report. Chapter 12—Low Impact Development. November 2007.

What is Green Infrastructure, US EPA. Retrieved June 2014

http://water.epa.gov/infrastructure/greeninfrastructure/gi_what.cfm

Vegetation for Erosion and Sediment Control

Introduction

A dense, vigorous growing vegetative cover protects the soil surface from raindrop impact, a major force in causing erosion and sedimentation. Also, vegetation will shield the soil surface from the scouring effect of overland flow and decreases the erosive capacity of the flowing water by reducing its velocity.

The shielding effect of a plant canopy is augmented by roots and rhizomes that hold the soil, improve its physical condition, and increase the rate of infiltration, further decreasing runoff. Plants also reduce the moisture content of the soil through transpiration, thus increasing the soils capacity to absorb water.

Suitable vegetative cover offers excellent erosion protection and sediment control. Vegetative cover is essential to the design and stabilization of many structural erosion control practices. Vegetative cover is relatively inexpensive to achieve and maintain. Also, it is often the only practical, long-term solution to stabilization and erosion control on many disturbed sites.

Timely vegetative establishment or preservation reduces the cost of vegetation, minimizes maintenance, and repairs, and makes structural erosion control measures more effective and less costly to maintain. Landscaping is also less costly where soils have not been eroded. Natural areas (those left undisturbed) can provide low-maintenance landscaping, shade, and screening. Large trees increase property values if they are properly protected during construction.

Besides preventing erosion, healthy vegetative cover provides a stable land surface that absorbs rainfall, cuts down on heat reflectance and dust, and complements architecture. Property values can be increased dramatically by small investments in erosion control.

Plant selection should be considered early in the process of preparing the erosion and sediment control plan. A diversity of species can be grown in Alabama due to the variation in both soils and climate. However, for practical, economic stabilization and long-term protection of disturbed sites, plant selection should be made with care. Many plants that will grow in Alabama are inappropriate for soil stabilization because they do not protect the soil effectively, or they cannot be established quickly. Some plants may be very effective for soil stabilization but are not aesthetically acceptable on some sites.

Stabilization of most disturbed sites requires grasses and/or legumes that grow close together to provide a thick close-growing cover. This is true even where part or the entire site is planted to trees or shrubs. In landscape plantings, disturbed areas between trees and shrubs must also be protected either by mulching or by permanent grass, legumes, or mixtures.

Trees are excellent for long-term soil and water protection, but they will not stabilize concentrated flow areas.

Lists of appropriate native vegetation for specific GI/LID practices as well as example planting plans can be found in the Low Impact Development Handbook for the State of Alabama previously mentioned.

Site Planning for Tree Protection

Select trees to be saved before beginning construction and avoid equipment operations within the dripline of trees being retained. No tree should be destroyed or altered until the construction plans are final. Flood plains and wetlands should be left in their natural condition. Locate roadways to cause the least damage to valuable trees. Follow contours where feasible to minimize cuts and fills. Minimize trenching by locating several utilities in the same trench. Excavations for basements and utilities should be kept away from the dripline of trees.

Storage areas for construction materials and worker parking areas should be noted on the site plan and located where they will not cause soil compaction over roots.

When retaining existing trees in parking areas, leave enough ground ungraded around the tree to allow for its survival. Tree wells may be needed.

Locate erosion and sediment control measures within the limits of clearing and not in wooded areas to prevent deposition of sediment within the drip line of trees being preserved. Sediment basins should be constructed in the natural depressions, if possible, rather than in locations where extensive grading and tree removal will be required.

Selecting Trees to be Retained or Planted

Trees may be exposed to insufficient sunlight and water; high winds; heat radiation from highways and parking lots; pollutants from cars and industries; root amputation because of sewer, water, gas and electric lines; and pruning or “topping” because of power lines; and covering of roots by pavement and

compaction. These items make the selection and management of trees extremely important.

The proper development of a forested urban site requires a plan for tree retention or tree planting before construction begins. An overall requirement for selecting trees is that those trees selected should be appropriate for the proposed use of the development. The selection of tree species depends on the desired function of the tree, whether it be just erosion control or other functions such as shade, privacy screening, noise screening, appearance, enhancement of wildlife habitat or a combination of these. The following characteristics of a tree should be considered when choosing a tree to retain or plant.

Hardiness

Select trees that are recommended for the area. See practice Tree Planting on Disturbed Areas.

Mature Height and Spread

The eventual height of a tree must be considered in relation to location on the site to avoid future problems with buildings and utility lines.

Growth Rate

Some trees attain mature height at an early age, others take many years. Fast growing trees may be brittle and possibly short-lived while slow growing trees are usually less brittle and live longer.

Root System

Avoid trees which have fibrous roots which may cause damage to water lines, septic tanks or sidewalks and driveways.

Cleanliness

Maintenance problems can be avoided by not selecting trees that drop seedpods, cones, flowers, or twigs in large amounts.

Moisture and Fertility Requirements

If suitable soils with adequate fertility are not available, trees tolerant of poor growing conditions should be planted.

Ornamental Effects

If a tree is unusually attractive in appearance, some other shortcomings may be overlooked.

Evergreen vs. Deciduous

Evergreens retain their leaves throughout the year and are useful for privacy screens and noise barriers. Most deciduous trees drop their leaves in the fall and are preferable as shade trees. Some deciduous trees do not drop their leaves until spring.

Pest Resistance

Insects and disease problems exist among many trees. Each pest is related to the tree's species itself, its vigor, and the site on which it is planted. Where control techniques are available, the tree owner's commitment and ability to apply them to a pest problem will determine whether the tree should be planted.

Life Expectancy and Present Age

Tree species with expected long life spans should be favored. Long-lived species that are old may succumb to the stresses of construction, so younger trees of desirable species are preferred since they are more resilient and will last longer.

Health and Disease Susceptibility

Unhealthy trees and those with damaged areas should be considered for removal.

Structure

Check for structural defects that indicate weakness or reduce the aesthetic value of a tree: trees growing from old stumps, large trees with overhanging limbs that endanger property, trees with brittle wood, misshapen trunks or crowns, and small crowns at the top of tall trunks. Trees with strong tap or fibrous root systems are preferred to trees with weak rooting habits.

Aesthetics

Trees that are attractive and pleasing to the eye are desirable. Trees that have beauty during several seasons of the year are desirable and add value to the site.

Comfort

Trees provide cooling during the summer and buffer the cold winds of winter. Summer temperatures may be 10 degrees cooler under hardwoods than under conifers. Most deciduous trees drop their leaves in winter, allowing the sun to warm buildings and soil. Evergreens are more effective wind buffers.

Wildlife

Preference may be given to trees that provide food and cover for wildlife.

Relationship to Other Trees

Trees growing alone generally are more valuable than trees growing in groups but trees in groups are more effective in preventing erosion and reducing stormwater runoff.

Suitability for the Site

Consider the height and spread of trees and how they may interfere with proposed structures and overhead utilities. Roots may interfere with walls, walks, driveways, patios, parking lots, waterlines, and septic systems.

Desirable trees should be identified and located on a map as part of the planning process.

Exotic Invasive Species

Exotic invasive species should not be planted! We have learned over the years that although a specimen tree, such as a Bradford pear, may be beautiful at a particular site there will likely be adverse impacts in later years. In the case of Bradford pear, its seed are spread by animals and it is becoming an unwanted plant pest throughout the state. Although promoted earlier as sterile, Bradford pears can cross-pollinate with other pear trees. The seeds from this may result in callery pear, native to East Asia, an extremely invasive species with thorns 3 – 4 inches long. The callery pear is a very undesirable tree that has no place on our landscapes!

Damage to Trees from Construction

Construction activities expose existing trees to a variety of stresses resulting in injury ranging from superficial wounds to death. Understanding the types of damages that may occur to trees is important in planning for protection.

Surface Impacts

Tree trunks are often damaged during construction activities. Trees scarred by construction equipment are more susceptible to damage by insects and disease. Excessive pruning of trees to prevent contact with utility lines or buildings may destroy the visual appeal of the tree, may provide a source of entry for disease causing fungi, or it may kill the tree.

Wind damage is a greater potential problem especially when some of the trees have been removed from a group of trees because the survivors are exposed to greater wind velocities. Also, trees develop root anchorage where it is needed the most. Isolated trees develop anchorage rather equally all around with stronger root development on the side of the prevailing wind. The more a tree has been protected from the wind the less anchorage it usually has. The result of thinning of trees may be that some of the remaining trees are blown over by strong winds (windthrow). A factor related to thinning is that thinning in favor of a single tall tree increases the hazard of lightning strike.

Root Zone Impacts

Disturbing the relationship between soil and tree roots can damage or kill a tree. The roots of an existing tree are established in an area where a specific environment of soil, water, oxygen, and nutrients are present. The mass of the root system must be the correct size to balance the intake of water from the soil with the transpiration of water from the leaves.

Raising the grade as little as 6” can retard the normal exchange of air and gases. Roots may suffocate due to lack of oxygen or be damaged by toxic gases and chemicals released by soil bacteria. Raising the grade may also elevate the water table and change the potential of the soil to function as a growing medium suitable for the trees that were growing there before the filling occurred.

Lowering the grade is usually not as damaging as elevating the grade. Shallow cuts of 6” to 8” will remove most of the topsoil and some feeder roots and expose some to drying and freezing. Deep cuts may sever a large portion of the root system, depriving the tree of water and increasing the chance of windthrow. Lowering the grade may also lower the water table.

Trenching or excavating through a tree’s root system eliminates part of the root system and can be very detrimental. Trees which lose as much as 40 percent of their root system usually die within 2 to 5 years. Tunneling may be a better alternative with species that do not have tap roots.

Soil compaction caused by heavy equipment, materials storage, and paving within the drip line of trees restricts air and water from roots by reducing pore space of the soil and by reducing infiltration.

Site Considerations for Non-woody Vegetation

Species selection, establishment methods, and maintenance procedures should be based on site characteristics, including soils, slope, aspect, climate, and expected management.

Soils

Many soils characteristics, including acidity, moisture retention, drainage, texture, organic matter, fertility, and slope influence the selection of plants and their establishment requirements. For example, bahiagrass and centipede are suited to droughty soils since they are more drought tolerant than most other grasses. One characteristic that will not be found in tables is the occurrence of compaction created incidentally as a result of equipment traffic, especially when the soil is wet or moist. Compaction can have an extremely adverse impact on plant establishment and maintenance and should be addressed before establishment of vegetative cover. The Web Soil Survey provides some information about soil features related to plants (See Appendix Soils in Alabama for more Web Soil Survey information).

Slope

The steeper the slope, the more essential is a vigorous vegetative cover. Good establishment practices, including seedbed preparation, liming fertilizing, proper planting, mulching, and anchoring of mulch are critical. The degree of slope may limit the equipment that can be used in seedbed preparation, planting, and maintenance.

Woody plants, shrubs, vines, and trees generally provide better long-term erosion control on steep slopes. These may be more costly and slower to establish but can provide substantial savings in maintenance. Also, they can be more desirable in the overall landscape plan.

Aspect

Aspect affects soil temperature and available moisture. South and west facing slopes tend to be warmer and drier, and often require special treatment. Warm season species tend to do better on south and west facing slopes in Alabama because they are usually more drought and heat tolerant.

Climate

The regional climate must be considered in selecting well adapted plant species. Species adaptation and seeding dates in Alabama are based on three broad geographical areas: North, Central, and South. Climatic differences determine the appropriate plant selections based on such factors as cold-hardiness, heat tolerance, and tolerance to a cool growing season.

Management Requirements

When selecting plant species for erosion control and stabilization, the post-construction land use and the expected level of maintenance must be considered. In every case, future site management is an important factor in plant selection.

Select plant species that are wear resistant and have rapid wear recovery for sites that receive heavy use, such as a sports field. A wear resistant plant that also recovers rapidly from foot traffic is bermudagrass. Bermudagrass also has a fast establishment rate and is adapted to all geographical areas in Alabama.

Where a neat appearance is desired, use plants that respond to frequent mowing and other types of intensive maintenance. Likely choices for quality turf in north Alabama are bermudagrass or tall fescue, while in central or south Alabama bermudagrass, centipede, or zoysia are good choices.

At sites where low maintenance is desired, low fertility requirements and vegetation persistence are particularly important. *Sericea lespedeza* and tall fescue are good choices in north Alabama while bahiagrass and centipede do well in central and south Alabama.

Seasonal Considerations for Non-Woody Vegetation

Newly constructed sites should be seeded or sodded as soon as possible after grading. Grading operations should be planned around optimal seeding dates for the particular region, where feasible. The most effective times for planting perennial grasses and legumes generally extend from March through May and from late August through October. Outside these dates the probability of failure is higher. If the time of year is not suitable for seeding permanent cover (perennial species) a temporary cover should be planted. Temporary seedings of annual species (small grains, ryegrass, millets etc.) often succeed at times of the year that are unsuitable for seeding permanent (perennial) species. Planting dates may differ for temporary species depending on the geographical area of Alabama.

Growing seasons must be considered when selecting species. Grasses and legumes are usually classified as warm-season or cool-season in reference to their season of growth. Cool-season species produce most of their growth during the fall and spring and are relatively inactive or dormant during the hot summer months. Therefore, early fall is the most dependable time to plant them. Warm-season plants grow most actively during the spring and summer and go dormant after the first frost in the fall. Spring and early summer are the preferred planting times for warm-season species.

Selecting Grasses and/or Legumes

Mixtures vs. Single Species Plantings

A mixture may be more desirable than a single species. Mixtures can be selected to provide cover more quickly and can be more enduring than a single species. Mixtures need not be elaborate. The addition of a quick-growing perennial provides early protection and facilitates establishment of a slower growing long-lived perennial, i.e., common bermudagrass with centipede. It is important to evaluate the merits and weakness of each species in selecting the mixtures for the specific site to be treated. If a quick establishing species such as common bermudagrass is planned for the final cover then a mixture is probably not appropriate.

Companion or “Nurse” Crop

The addition of a companion or “nurse” crop (quick-growing annual or weak perennial added to permanent mixtures) is a good practice on difficult sites, late seeding, or in situations where the development of permanent cover is likely to be enhanced, i.e., crimson clover or rye (cereal). The companion crop germinates and grows rapidly, holding the soil until the perennial species becomes established. The seeding rate of the companion crop must be limited to avoid crowding and competing with the desired perennial species, especially under optimum growing conditions. It is important to not plant a nurse crop that will compete to the detriment of the desired species.

Plant Species Selection

Information on plant species adapted for soil stabilization use in Alabama is contained later in this chapter and in the tables associated with the practices that are

used for plantings. Using this information makes plant selection straight-forward for most situations. Specific seeding rates and planting dates are given in the tables of the practices.

Annuals

Annual plants grow rapidly, then mature and die in one growing season. They are useful for quick, temporary cover or as a companion crop for slower growing perennials.

Cool - Season Annuals

Small Grain

Rye (cereal) is usually superior to other small grains (wheat, oats, or barley) for temporary cover. It has more cold hardiness than other small grains and will germinate and grow at lower temperatures. It will provide more fall and early winter growth and matures earlier than other small grains. Rye germinates quickly and is tolerant of poor soils. Including rye in fall seeded perennial mixtures is particularly helpful on difficult soils and erodible slopes or when seeding is late. However, seeding rates of rye should be limited to the suggested rates because a thick stand will suppress the growth of perennial seedlings. No more than 60 lbs/acre should be planted when rye is used as a companion crop. Rye grows fairly tall in the spring which may be undesirable. If this is a problem some of the shorter growing varieties of wheat may be used.

Annual Ryegrass

Annual ryegrass is outstanding for temporary cover because it provides dense cover rapidly. **It is not recommended for use as a companion crop in perennial mixtures in Alabama because it is highly competitive and crowds out most other species, leaving no lasting cover.** Also, if allowed to mature the seed volunteers and can seriously interfere with subsequent efforts to establish permanent cover.

Warm – Season Annuals

Millets

Millets (Browntop, Foxtail) are warm season annuals, useful for temporary seeding or as a nurse crop. Browntop millet has early rapid growth and grows to 2 to 3 feet in height. Foxtail is a fine stemmed plant growing to a height of 4 to 5 feet. The leaves are broad and flat. Foxtail millets do best under fairly abundant moisture conditions.

Sudangrass and Sorghum-sudangrass Hybrids

Sudangrass and sorghum-sudangrass hybrids, like the millets, are warm season annuals which are useful for temporary vegetation. The small stemmed, shorter

growing varieties are more satisfactory for temporary vegetation than the tall coarse-stemmed varieties.

Annual Lespedeza

Annual lespedeza is a warm-season reseeding annual legume that grows to a height of 6-12". It is tolerant of low fertility and is adapted to the climate and most soils throughout Alabama. It is not adapted to alkaline soils of the Black Belt or deep sands. It is a good companion crop for spring planted sericea lespedeza, filling in weak or spotty stands the first season without suppressing the sericea. Annual lespedeza can heal thin areas in the perennial cover for several years after initial establishment. Two species of annual lespedeza are grown in Alabama. "Common" annual lespedeza volunteers in many parts of Alabama and is sold under the variety name Kobe. Korean lespedeza is a slightly larger, coarser and earlier-maturing plant sold under several variety names. Kobe is superior on sandy soils and preferable in south Alabama. Korean is better in north Alabama because the seeds mature earlier.

The preferred seeding dates for annual lespedeza are in the late winter to early spring. It can be included with a fall seeding; in which case some seeds remain dormant over the winter and germinate the following spring.

Cool-Season Perennials

Perennial plants, once established, will live for more than one year. They may die back during a dormant period but will grow back from their underground tubers or rhizomes in succeeding years. Stands of perennials will persist for a number of years under proper management and environmental conditions.

Cool-season perennials produce most of their growth during the spring and fall and are more cold-hardy than most warm-season species. Tall fescue is the only cool-season perennial grass recommended for vegetating disturbed soils in Alabama. A description of tall fescue follows.

Tall Fescue

Tall fescue, a cool-season grass, is the most widely used species in north Alabama for erosion control. It is well adapted to all of north Alabama and all but the droughty soils of central Alabama. Also, it can be grown on the Black Belt soils of Alabama. It thrives in full sun to partial shade and is fairly easy to establish. Liberal fertilization and proper liming are essential for prompt establishment, but once established it can tolerate minimal maintenance almost indefinitely. It will provide stabilization the year of establishment if planted early during the planting period. Because tall fescue has a bunch growth habit, it is slow to fill in areas with poor stands. Therefore, some replanting may be required on eroded areas or areas of spotty stands to complete stand establishment. Fescue does not tolerate frequent and close mowing during the summer, especially on sites that are droughty.

White Clover

White clover is sometimes planted with tall fescue. It is usually short-lived.

Crownvetch

Crownvetch is a deep-rooted, perennial legume adapted only to north exposures in the northern tier of counties in Alabama. It is useful on steep slopes and rocky areas that are likely to be left unmowed. Crownvetch requires a specific inoculant. Because site requirements are so unique, crownvetch is not included in this handbook as a species to plant (in Alabama).

Warm-Season Perennials

Warm-season perennials initiate growth later in the spring than cool-season species and experience their greatest growth during the hot summer months. Most species of warm-season perennials do better in the southern one-half of Alabama, but there are species or varieties that will grow in north Alabama. The following grasses have proven the most useful for soil stabilization.

Bahiagrass

Bahiagrass is a warm-season perennial grass particularly well adapted for growing on sandy soils in the southern half of Alabama. It will tolerate acid and low fertility soils, grow in full sun to light shade, and persist almost indefinitely with little or no maintenance after it is established. However, bahiagrass seedlings are small and lack the vigor some species of warm-season grasses possess; it usually takes 2 years to establish a good sod. Bahiagrass is established with seed.

Bahiagrass produces a fairly dense sod suitable for low maintenance areas. It has a high resistance to wear and recovers fairly fast from wear. It produces rhizomes and will fill in small bare spots, but not fast like bermudagrass. Bahiagrass produces seed heads about one to 2 feet in height throughout the growing season and, where this is not a problem, it is probably the best choice for stabilizing soil in the southern one half of the State. It grows slowly in the northern part of the state and is not recommended for erosion control plantings. Pensacola is the recommended variety of bahiagrass for soil stabilization in Alabama. It is more tolerant to upland sites and more cold tolerant than Argentine bahiagrass. Argentine bahiagrass is not recommended for erosion control in Alabama.

Common Bermudagrass

Common Bermudagrass is a long-lived perennial that spreads by stolons and rhizomes. It will grow in all areas of the State on suitable sites. It is best adapted to well-drained fertile soils and will survive extreme heat and drought. It does poorly on extremely droughty sandy soils and will not grow on poorly drained soils. It is not shade tolerant. It responds well to fertilizer and will establish a dense sod quickly from seed. Bermudagrass requires more maintenance than bahiagrass and, if a regular maintenance fertility program is not used, it will tend to slowly decline.

It has a high resistance to wear and recovers quickly from wear which makes it a good choice for heavy use areas that have high fertility.

There are two types of bermudagrass which are important in soil stabilization: common bermudagrass, which can be established with seed or sprigs, and turf-type bermudagrasses which must be established from vegetative material. Common has longer internodes and larger leaves than the turf-type hybrid bermudagrass. When using common bermudagrass for permanent vegetation, only seed that is pure common bermudagrass should be planted. Common bermudagrass seed are often contaminated with giant-type bermudagrass seed. Giant-type bermudagrass is very competitive and fast growing, but it is not cold hardy in Alabama. So, when common bermudagrass seed contains even a small percent of giant type bermudagrass seed, they will be “choked out” by the giant-type bermudagrass. Since the giant-type bermudagrass will be killed by a cold winter, a good bermudagrass sod the year of establishment can become a poor stand the following year.

The turf type hybrid bermudagrass varieties have fine leaves and short internodes which make them desirable for lawn, golf courses and other areas where a quality turf is desired. However, turf type hybrid bermudagrass is more costly to establish because it must be planted from sprigs, plugs, or solid sodded.

The agronomic varieties of hybrid bermudagrass, such as Coastal, do not lend themselves to soil stabilization of construction areas. The height may be undesirable in certain areas and they too must be established with vegetative material which usually makes them too costly to establish. Also, the stand declines without costly maintenance.

Sericea Lespedeza

Sericea lespedeza, or sericea as it is commonly known, is a deep-rooted, drought resistant perennial legume, adapted to all but the poorly drained and deep sandy soils of Alabama. It is long-lived, tolerant of low fertility soils, pest free, and will fix nitrogen. It can be a valuable component in most low maintenance mixtures. Sericea is slow to establish and will not contribute much to prevention of erosion the first year; however, once established it persists indefinitely on suitable sites. Where esthetic is important, sericea may be considered unsightly because the old top growth breaks down slowly and the previous years' growth is conspicuous in following years. It may invade adjoining sites that have full sunlight and is recognized by the forest industry as an invasive species.

Plantings that include sericea should usually include a companion crop such as annual lespedeza or common bermudagrass. Sericea should be planted as early as possible within the planting date to avoid as much weed competition as possible. Also, sericea may be planted in the late fall and winter months because many of the seed will lie dormant until the following spring.

Sericea does not tolerate frequent mowing and late mowing before frost because these mowing regimes deplete food reserves and adversely affect the stand the next year. Sericea has lost favor as a roadside plant since it is not tolerant to chemical

spray treatments often used on roadsides to control weeds and to retard growth of favored grasses.

Selecting Shrubs, Vines and Groundcovers to be Retained or Planted

As with trees, several plant characteristics and environmental requirements should be considered when selecting shrubs, vines and groundcovers. Closer adherence to plant requirements yield a greater chance of achieving a successful landscape.

Hardiness

Plants have varying capacities to tolerate cold or heat. Cold tolerance is of most concern. The state of Alabama spans two major plant hardiness zones, Zone 7 (from the central part of the state northward) and Zone 8 (the southern half of the state). The zones are determined by the range of average annual minimum temperatures. The average range of minimum temperatures for Zone 7 is 0 to 10 degrees F; for Zone 8 it is 10 to 20 degrees F (See Plant Adaptation Zones in practice Shrub, Vine and Groundcover Planting).

Landscape plants which are not capable of tolerating temperatures below 10 degrees should not be expected to escape injury during an average winter in Zone 7. However, they should be adequately adapted to Zone 8.

Plant hardiness can be greatly influenced by nearby bodies of water since water buffers change in temperature. Structures or other plants can moderate extreme temperatures and shelter landscape plants, enabling marginal species to better tolerate winter conditions.

Summer Heat Tolerance

A plant's capacity to survive the stress of high temperature is also a concern. Heat interacts with other environmental factors, especially soil moisture conditions and sunlight to influence the range of adaptability of a plant. Usually associated with high temperatures is rapid depletion of soil moisture, especially in late summer. Direct sunlight increases the severity of heat effects on plants. Since Alabama has periods of high temperatures and short winters, spruce, hemlock, and yew are generally poor performers.

Moisture Requirements and Soil Drainage

Landscape plants vary widely in the amount of moisture they need to thrive. If a drought tolerant plant receives a lot of rain, it can be more susceptible to invasion by normally weak pathogens, especially where the soil drains slowly. On the other hand, plants which require large amounts of water for best performance are easily drought stressed when water is withheld or if planted in very well-drained soils. Such conditions may actually attract insect pests to stressed plants.

Plants that normally require a lot of water can be irrigated so that the ornamental attributes of the plant are maintained. However, this is a use of water resources that can be avoided if consideration is given to appropriate plant selection.

Soil pH

Soil pH can have a profound influence on the performance of landscape plants. However, most landscape plants perform adequately within a soil pH range of 5.5 to 6.2. Plants listed in Tables SVG 1-5 should grow satisfactorily within this pH range.

Plant Pest Susceptibility

It is unwise to use pest-susceptible plants in areas where those particular pests thrive. For example, most species of euonymus are attacked by euonymus scale. Other landscape options for plant materials might be selected which do not have the same susceptibilities. Most plants listed in Tables SVG 1-5 have few major pest problems.

Nutritional Requirements

Newly set plants often require little additional fertilizer because of the presence of residual fertilizer in the root ball. At this stage, supplying water is far more important than adding fertilizer. Also, most well-established shrubs require less fertilizer to maintain an attractive plant than is usually required by poorly established shrubs.

Light Requirement

Plants which require full sun (at least 8 hours of direct sunlight per day) are weakened in low light situations. Plants that need some shade are often vigorous and unattractive in full sun.

Rate of Growth and Mature Size

Obviously, for rapid cover, faster-growing plants are desired. However, mature size and other plant characteristics should be considered. For example, where a screen is needed, a slower-growing evergreen shrub may be desired over a fast-growing deciduous plant. Take all plant characteristics into account when selecting plants for a site. If money is available, both needs can be met by planting fast growing, short-lived plants to provide a quick screen and at the same time planting slower growing plants and allowing them to mature. When the fast-growing plants become overgrown, they can be removed to allow the more desirable plants to take their place.

Treating Sites to Establish Grass, Legumes, Shrubs, Vines and Groundcover

Topsoiling

The surface layer of an undisturbed soil is often rich in organic matter and has physical, chemical, and biological properties that make it a desirable planting and growth medium. These qualities are particularly beneficial to plant establishment. Consequently, where practical, topsoil should be stripped prior to construction and

stockpiled for use in final vegetation of the site. Stockpiling topsoil may eliminate costly amendments and repair measures later. Topsoil may not be required for the establishment of less demanding, lower maintenance plants, but it is essential on sites having shallow soils or soils with other severe limitations. It is essential for establishing fine turf and ornamentals.

The need for topsoil should be evaluated, taking into account the amount and quantity of available topsoil and weighing this against the difficulty of preparing a good seedbed on the existing subsoil. Where a limited amount of topsoil is available, it should be reserved for use on the most critical areas. “Engineered” biotic products are available that can enhance stand establishment when topsoil is limited or unavailable.

Soil Amendments

Lime is almost always required on disturbed sites in Alabama to decrease soil acidity. Lime raises the pH, reduces exchangeable aluminum, and supplies calcium and magnesium for vigorous plant growth. Only the alkaline soils of the Black Belt and north Alabama do not require lime. A soil test should be used to determine the need for liming materials.

Plant nutrients, such as phosphorus and potassium, will usually be required even on the best soils. Plant nutrient application rates for a particular species of vegetative cover should be applied according to a soil test report.

Soil amendments should be applied uniformly and well mixed with the top 6” of soil during seedbed preparation.

Site Preparation

The soil on a disturbed site must be modified to provide an optimum environment for germination and growth. Addition of topsoil, soil amendments, and tillage are used to prepare a good seedbed. At planting, the soil must be loose enough for water infiltration and root penetration, but firm enough to retain moisture for seedling growth. Tillage generally involves disking, harrowing, chiseling, or some similar method of land preparation. Tillage should be done on the contour where feasible to reduce runoff and erosion. Lime and fertilizer should be incorporated during the tillage.

Planting Methods

Seeding is by far the fastest and most economical establishment method that can be used with most species. Seedbed preparation, liming, and fertilization are essentially the same regardless of the establishment method chosen.

Uniform seed distribution is essential. This is best obtained using a cyclone seeder, conventional grain drill, drill seeder, cultipacker seeder, or hydraulic seeder. The drills and cultipacker seeder are pulled by a tractor and require a fairly clean, smooth seedbed.

Seeding rates recommended in this handbook are for Pure Live Seed and take into account the “insurance” effect of extra seed. Rates exceeding those given are not recommended because over dense stands are more subject to drought, competitive interference and are unnecessarily costly.

Because uniform distribution is difficult to achieve with hand broadcasting, it should be considered only as a last resort. When hand broadcasting of seed is necessary, uneven distribution may be minimized by applying half the seed in one direction and the other half at right angles to the first. Small seed should be mixed with sand for better distraction.

A drill seeder (or no-till planter) can plant seed into an existing cover or mulch or be used to restore or repair a weak stand. It can be used on moderately uneven, rough surfaces. It is designed to penetrate the sod, or other residue such as dead temporary cover, open narrow slits, and deposit seed with a minimum of surface disturbance. Drill seeding minimizes the need for applying additional mulching materials.

Hydroseeding, a combined application of hydromulch and vegetative seed, may be the most effective seeding method on steep slopes where equipment cannot work safely. A rough surface is particularly important when preparing slopes for hydroseeding. In contrast to other seeding methods, a rugged or rough seedbed gives the best results when hydroseeding is used. Soil amendments such as lime and fertilizer may cause damage to seeds during the mixing process, reducing germination and establishment. Such amendments should be applied before a hydroseeding application.

Sprigging refers to planting stem fragments consisting of runners (stolons) or lateral, below-ground stems (rhizomes), which are sold by the bushel. Sprigs can be broadcast or planted in furrows using a transplanter. This method works well with bermudagrass. Also, sprigs may be broadcast and covered with soil by light disking, and cultipacking. Broadcasting is easier but requires more planting material. Common bermudagrass will cover over much more quickly than the turf type bermudagrass varieties.

Plugging differs from sprigging only in the use of plugs cut from established sod, in place of sprigs. It requires more planting stock, but usually produces a complete cover more quickly than sprigging. It is sometimes used to introduce a superior grass into an established turf.

In sodding, the soil surface is completely covered by laying cut sections of turf. Turf-type bermuda, centipede, and zoysia are usually the types of turf used for sodding. Plantings must be watered immediately after planting and kept well-watered until the rooting systems become incorporated with the underlying soil, usually 1-2 weeks.

Sodding, though quite expensive, is warranted where immediate establishment is required, as in stabilizing grass swales and steep slopes, or in the establishment of high quality turf. If properly done, it is the most dependable method and the most flexible in seasonal requirements. Sodding can be done almost any time of the year in Alabama. Moisture availability is essential to establishing a sod during the

growing season and, therefore, watering should be considered when developing the planting plan.

Inoculation of Legumes

Legumes have bacteria called rhizobia which invade the root hairs and form gall like “nodules”. The host plant supplies carbohydrates to the bacteria, which supply the plant with nitrogen compounds fixed from the atmosphere. A healthy stand of legumes, therefore, does not require nitrogen fertilizer. Rhizobium species are host specific in that a given species will inoculate some legumes but not others. Therefore, successful establishment of legumes requires the presence of specific strains of nodule forming, nitrogen fixing bacteria on their roots. In areas where a legume has been growing, sufficient bacteria may be present in the soil to inoculate seeded plants, but in other areas the natural Rhizobium population may be too low. If the specific Rhizobium is not already present, it must be supplied by mixing it with the seed at planting or using seed coated with the Rhizobium. Cultures for inoculating various legume seed are available through seed dealers.

Among the legumes listed for use in this handbook, crimson clover is the only one generally requiring inoculation. Lespedeza nodule bacteria are widely distributed in the soils of Alabama unless the site has had all surface soil removed.

Irrigation

Irrigation, though not usually required except for Sodding, can extend seeding dates into the summer and ensure seedling establishment. Damage can be caused by both under and over irrigating. If the amount of water applied penetrates only the first few inches of soil, plants may develop shallow root systems that are prone to desiccation during droughts. If supplementary water is used to get seedlings up, it must be continued until plants become completely established.

Mulching

Mulch is essential to the successful establishment of vegetation on most disturbed sites. Mulch protects sites from erosion until the vegetation is established. In addition, mulch aids seed germination and seedling growth by reducing evaporation, preventing soil crusting, and insulating the soil against rapid temperature changes.

Mulch may be used also to protect surfaces that cannot be seeded. Mulch prevents erosion in the same manner as vegetation, by protecting the surface from raindrop impact and by reducing the velocity of overland flow.

Small grain straw (wheat, oats, barley or rye) is the most widely used and one of the best mulch materials. However, there are other materials, including manufactured mulches that work well. Mulching materials covered in this handbook have their respective advantages and appropriate applications, and a material should not be selected on the basis of cost alone. The effectiveness of straw mulch is increased by crimping or tacking and crimping or tacking should usually be a requirement.

Maintenance

Satisfactory stabilization and erosion control requires a complete vegetative cover. Even small breaches in vegetative cover can expand rapidly and, if not repaired, can result in excessive soil loss, sediment delivery, and turbid runoff from an otherwise stable site. A single heavy rain will enlarge rills and bare spots and the longer repairs are delayed the costlier they become. Prompt action will keep soil loss, sediment damage, and repair costs down. New plantings should be inspected frequently, and maintenance performed as needed. If rills and eroded areas develop, they must be repaired, seeded, and mulched as soon as possible.

Maintenance requirements extend beyond the seeding phase. Damage to vegetation from disease, insects, traffic, etc., can occur at any time. Pest control (weed or insect) may be needed at any time. Weak or damaged spots must be fertilized, seeded and mulched as promptly as possible.

Frequency and amount of fertilizer to apply for maintenance can best be determined through periodic soil testing. Maintenance requirements should always be considered when selecting plant species for vegetation.

Measures for Stabilizing Coastal Dunes

Introduction

Dunes are reservoirs of sand that help keep a seashore intact. They act as flexible barriers to high tides and waves and dissipate energy that can cause shore recession (beach erosion). Coastal dune ridges block the movement of storm tides and waves into the low-lying areas behind a beach. If they do give way to storm winds and water, these shifting mounds of sand will soon reappear. Dunes are not effective, however, against persistent, continuous beach erosion caused by permanent changes in the shoreline.

Dunes are formed by waves and wind, and when unstable, they are extremely vulnerable to these same forces. They may be stabilized by grasses and woody plants that are well adapted to this environment.

Dunes stabilized with grasses provide for enrichment of dunes, a natural barrier, reducing the velocity of waves and absorbing their energy. These stabilizing plants are tolerant of salt, intense heat, soils lacking humus, and a limited water supply. As sand piles up around beach grass plants, new shoots emerge from the sand surface and trap more windblown sand. Structures such as crosswalks and sand fences also catch and hold sand and help to build or repair dunes.

Dune stabilization projects usually require a combination of vegetative and structural measures. They include planting adapted dune grasses, providing adequate moisture during the first growing season (often with an irrigation system), and constructing walkover structures to prevent pedestrian traffic from destroying dune vegetation. The use of sand fences and dune vegetative plantings are more effective than using either vegetation or structural measures alone.

Selecting Vegetative Measures

There are only a few plant species that are tolerant of the stresses of the beach environment. These plants must be able to survive being buried by blowing sand, sand blasting, salt spray, saltwater flooding, drought, heat, and low nutrient supply. Perennial grasses are effective under these conditions. From 1984 to 1989, the USDA, Natural Resources Conservation Service (formerly Soil Conservation Service) Jimmy Carter Plant Materials Center (PMC) evaluated sea oats, marshhay cordgrass, and bitter panicum for dune stabilization on Tybee, Jekyll, and St. Simons Islands Georgia, and at Gulf Shores Alabama. As a result, the Jimmy Carter PMC recommends the following plant materials for coastal dune stabilization: sea oats (*Uniola paniculata*); 'FLAGEO' marshhay cordgrass (*Spartina patens*); 'NORTHPA' bitter panicum (*Panicum amarum*); 'SOUTHPA' bitter panicum (*Panicum amarum*); 'ATLANTIC' coastal panicgrass (*Panicum amarum* var. *amarulum*).

Sea Oats

Sea oats is a warm-season dune grass ranging throughout the Gulf and south Atlantic coastal region from southeastern Virginia to Mexico. It is vigorous, drought tolerant, heat tolerant and relatively free of pests. This perennial is the most important and widespread grass on southern coastal dunes.

The leaves are narrow and pale green, and in northern locations, they die back close to the ground each winter. The seed head matures in the fall and has compressed spikelets at the end of stiff stems 3 feet long or more.

Sea oats can be established by digging and dividing native plants, or from small potted plants grown from seed that are commercially available. Under natural conditions, seed germination is not high and seedling survival is low. When replanting seedlings, set the stock at least 1 foot deep into the sand and pack it tightly.

'FLAGEO' Marshhay Cordgrass

'FLAGEO' marshhay cordgrass was cooperatively released in 1990 by the NRCS Jimmy Carter PMC, the Brooksville PMC (Florida) and Fort Valley State College in Fort Valley, Georgia. This perennial occurs on dunes throughout the south Atlantic and Gulf regions and in Puerto Rico and is especially salt tolerant.

The stems of marshhay cordgrass are slender and grow 2 to 3 feet tall and the leaves are rolled inward, resembling rushes. The seed head is composed of two or more compressed spikes attached at nearly a right angle to the culm. The plant spreads by means of a network of slender rhizomes.

Plantings of vegetative material in early spring can be successful. For large plantings, bare root planting stock is recommended. Stems rooted at the base, preferably with a section of rhizome attached, can be planted at a depth of 4" to 5".

'NORTHPA' and 'SOUTHPA' Bitter Panicum

'NORTHPA' and 'SOUTHPA' bitter panicum varieties were released by the Brooksville, PMC in 1992. Vegetative plant material is commercially available.

Bitter panicum is a perennial grass found throughout the south Atlantic and Gulf regions. It is most common in southern Florida and Texas.

The plant grows to an average height of 3 to 4 feet. The leaves are smooth and bluish green, and the seed head is narrow, compressed, and generally sparsely seeded. The plant spreads from an aggressive, scattered system of rhizomes, but the stands are rather open.

Bitter panicum produces few viable seed, and it is better adapted for transplanting than sea oats. It can be propagated from a stem with part of the rhizome attached or from an 8" to 12" length of rhizome without any above ground parts. Plant the rhizome 4" deep in early spring, spaced no more than 6 feet apart.

Another method of propagation is to snap off robust stems at ground level and plant them at an angle of about 45 degrees so that several nodes are buried.

'ATLANTIC' Coastal Panicgrass

'ATLANTIC' coastal panicgrass was released by the Cape May Plant Materials Center (New Jersey). Its origin is Princess Ann County, Virginia. Seed is commercially available.

'ATLANTIC' coastal panicgrass is a somewhat dense, upright perennial bunchgrass found on coastal dunes throughout the south Atlantic and Gulf regions. It is a dominant plant at many locations, especially in west Florida, Alabama, and Texas.

The stems are coarse, straight, stiff, and grow up to 4 feet tall. Partially compressed seed heads produce moderate amounts of viable seed each fall. The crowns enlarge slowly from short, almost vertical tillers.

It can be propagated by either seeding or planting divided plant parts. Plant the seed 1 to 3" deep in dune sand and mulch the area for best results. Seedling survival depends on adequate rainfall after germination. Clumps of coastal panicgrass can be dug, divided, and planted with good results during the summer rainy season.

Irrigation

Irrigation is required on all dune plantings to provide adequate moisture during the initial establishment period. The irrigation system will consist of mains and laterals, control zones, supports, control valves, fittings, and related hardware that is capable of applying ½" of water over the entire zone in an 8 hour period.

Structural Measures

The coastal dune stabilization plan should include structural measures such as dune walkovers and sand fences.

Dune Sand Fence

Dune sand fence is an artificial barrier of evenly spaced wooded slats or approved fabric erected perpendicular to the prevailing wind and supported by posts. It reduces wind velocity at the ground surface and traps blowing sand. Dune sand fences are used primarily to build frontal ocean dunes to control erosion and flooding from wave over wash.

Dune Walkover

Dune walkover structures control pedestrian traffic and keep traffic off of the sand, allowing the dune vegetation to establish and protect the dunes from erosion.

Dune Maintenance

Well stabilized dunes will not remain that way unless a reasonable maintenance program is followed. Major considerations include:

Control of Foot and Vehicular Traffic

The primary dune is intolerant of trampling. Traffic should be prevented to the extent possible. However, since dunes must be crossed to reach the beach, mechanical crossovers should be installed at selected sites. Elevated walkovers are satisfactory. These walkways should be curved to reduce wind erosion. The inland or secondary dune should also be protected from pedestrian and vehicular traffic.

Maintenance of Dune Line

A dune system is like a chain in that it is no stronger than its weakest point. Consequently, to receive maximum protection from dunes, a strong and uniform dune line must be maintained. Blow outs, wash pits, and other natural or human produced damage must be repaired quickly to prevent weakening of the entire protective dune system. Blow outs in a dune system can be repaired by placing sand fences between existing dunes and tying the ends of the fence into these dunes.

Maintain sand fences and erect additional sand fences as needed, until the eroding area has been permanently stabilized or until the dune has reached the desired height and is properly vegetated. Any loose or damaged boards on cross-over structures should be repaired or replaced.

Maintenance of Vegetation

Maintain plantings by applying fertilizer as needed to keep a healthy stand with the desired density. A minimum annual application of 50 lbs/acre of an inorganic

nitrogen fertilizer is usually needed for grass stands. Sparse areas should be replanted during the next planting season for the desired grass or legume.

Exotic Invasive Species

Introduction

Exotic invasive species are an increasing problem over the countryside. From well-known species such as kudzu and wisteria to lesser known plants such as cogongrass, it is important that exotic invasive species be understood, and appropriate measures be taken to prevent their introduction and spread on construction sites.

Some Invasive Species

Cogongrass came into Southern U.S. ports in the early 1900's as a packing material and slowly established along the Gulf coast (particularly in the Mobile area) for a number of years. More recently, it has spread along Interstates 10, 65, and other roads into many areas of Alabama by windblown seed and with mowing equipment moving from a contaminated site into another site. It is listed first because it is so invasive, so competitive to other plants, so hot when it burns, and so difficult to control. Every precaution should be taken to prevent its spread!

Chinese privet, while not commonly used in new landscape plantings, is a species that was once prized as a "hedge". Over the years, as a result of birds spreading the seed, privet has become established along the edge of many open sites and is invading open areas along streams and other sites that are undergoing plant succession. Privet is mentioned as an example of what can happen when an invasive species that is difficult to control is planted. A planner should recognize the importance of not using an invasive species even though the plant may be pretty or have other desirable characteristics.

There are too many invasive species to list them all, but a few others that definitely have the potential to be damaging to most landscapes and should not be planted include the following: autumn olive, Bradford pear, bush honeysuckle, giant reed, Japanese climbing fern, Japanese honeysuckle, and Pompa grass. The reference at the end of this section provides a comprehensive listing of species that may become a problem to forest sites and other sites that are not managed intensely.

There are a few invasive plants that will continue to be used in the erosion and sediment control industry that are potential problems in some situations but are used because there are no acceptable alternatives. These species include the following: bahiagrass, common bermudagrass, lovegrass, sericea lespedeza, and tall fescuegrass.

Addressing Invasives

There are two avenues for addressing invasive species. First, planners should be careful in specifying the species to plant. To this end, the tables for Shrub, Vine

and Groundcover Planting were revised in the 2014 revision of this Handbook to remove exotic invasive species. Second, species that can be spread by seed and vegetative parts, such as cogangrass, should be recognized and precautions should be taken by those that move equipment from one site to another, to prevent their equipment from moving seeds and plant parts to uncontaminated sites.

Excellent references are available to help in identifying invasive species and in planning ways to minimize their spread. One such reference is A Management Guide for Invasive Plants in Southern Forests, USDA Forest Service, Southern Research Station, General Technical Report SRS-131. For the most inclusive, up-to-date list of invasive plants of Alabama, refer to the Alabama Invasive Plant Council, www.se-eppc.org/alabama.

Chapter 3

Plan Preparation

What is a Plan for Erosion and Sediment Control and Stormwater Management

A plan for erosion and sediment control and stormwater management is the document which provides the practices and measures to prevent or reduce erosion on construction sites and minimize the impacts of sediment, turbidity and hydrologic changes off-site. It is the part of a Stormwater Pollution Prevention Plan (defined in glossary) or Construction Best Management Practices Plan (CBMPP) that identifies appropriate measures for erosion and sediment control for a specific construction site. Plan components are described in detail later in this chapter.

Practice designs are usually prepared after a plan is adopted and, therefore, designs are not considered a part of the plan. Design of practices may also require the plan to be modified based on design requirements. Practice design criteria in Chapter 4 and guidelines for Installation and Maintenance of Best Management Practices in Chapter 3 of Volume II provide a technical basis for developing sound specifications.

Who is Responsible for the Plan

The owner or lessee of the land planned for development or needing treatment from a previous disturbance has the responsibility for plan preparation and adequacy. Although the owner or lessee may designate a qualified design professional to prepare and implement the plan, the owner or lessee retains the ultimate responsibility.

If during construction it becomes obvious that additional practices or measures are needed or that the system that is planned is not appropriate, the shortcoming should be brought to the attention of the project manager for action by an appropriate design professional and concurrence by the owner or the owner's designee. In this scenario, additional planning must continue to ensure that the plan is up-to-date and adequate.

What Is an "Adequate" Plan

An adequate plan contains sufficient information to describe the system intended to control erosion on the construction site, minimize related off-site sediment delivery and turbidity and address potential problems associated with hydrologic changes off-site. The sequence of scheduling and installing BMPs are additional items of importance. If regulations exist, more details may be required to satisfy the

approving authority that the potential problems of erosion and sediment will be adequately addressed.

The length and complexity of the plan should be commensurate with the size and importance of the project, severity of site conditions, and the potential for off-site damage. Obviously, a plan for constructing a house on a single subdivision lot will not need to be as complex as a plan for a shopping center development. Plans for projects undertaken on relatively flat terrain will generally be less complicated than plans for projects constructed with steep slopes with higher erosion and sediment delivery potential. The greatest level of planning and detail should be evident on plans for projects which are adjacent to flowing streams, wetlands, dense population centers, high value properties, coastal resources and other critical habitats where damage may be particularly costly or detrimental to the environment.

The Step-by-Step Procedures for Plan Development outlined later in this chapter are recommended for the development of all plans. It is recognized that additional information may be needed to meet state and local requirements.

The checklist following the procedures can be used by qualified design professionals as a checklist for plan content and format.

General Considerations for Preparing Plans

Qualified design professionals should have a sound understanding of the state and local laws and regulations related to erosion and sediment control and stormwater management. In addition, they must be competent in the principles of erosion and sediment control and stormwater management.

Developers and qualified design professionals can minimize erosion, off-site sediment delivery, turbidity issues and other construction problems by selecting areas appropriate for the intended use because tracts of land vary in suitability for development. Knowing the soils, topography, natural landscape values, drainage patterns, receiving stream characteristics and classification, flooding potential, areas of contaminated soil, and other pertinent data are useful in identifying both beneficial features and potential problems and challenges of a site.

A plan should contain enough information to ensure that the party responsible for development of a site can install the measures in the correct sequence at the appropriate season of the year. Sufficient information should be included to provide for maintaining the practices and measures during construction and after installation has been completed. A schedule of regular inspections and repair of erosion and sediment control BMP's should be set forth to ensure that maintenance receives appropriate attention and is accomplished.

Will the development of the site result in increased peak rates of runoff? Will this result in flooding or channel degradation downstream? If so, considerations should be given to stormwater control structures on the site. Local ordinances related to stormwater management must be considered and met.

The length and complexity of a plan should be commensurate with the size and importance of the project, severity of site conditions, and the potential for off-site impacts. A plan may contain a description of the potential erosion and sediment-related problems. If a site is in the coastal zone, in a watershed with a formally designated impaired stream, or has contaminated soil or hazardous waste on the site, additional attention will be required during plan development – see Areas of Special Concern below.

For regulated sites in Alabama, the plan must satisfy the Alabama Department of Environmental Management requirement that the potential problems related to erosion, sediment and stormwater will be adequately addressed.

New or innovative conservation measures or modifications to standard measures in this handbook may be used if the proposed measure is expected by the qualified design professional to be as effective as the practice for which it is being substituted.

Where applicable, the plan for a site should be included in the general construction contract. To facilitate reviews and its use on the site, the plan should be prepared and assembled so that it may be reviewed as a separate document.

Areas of Special Concern

Contaminated Sites

For sites that are contaminated with hazardous constituents (based on background levels), care should be taken to ensure that the contamination is appropriately managed. When soil potentially containing hazardous constituents (based on background levels) is excavated at a site, it should be stored in covered roll-offs or some other conveyance until an adequate waste determination, as required by both State and federal law has been conducted. Soil that is contaminated above Alabama Department of Environmental Management established toxic concentrations or contaminated with listed hazardous wastes must be manifested and disposed at an approved hazardous waste treatment, storage, disposal (TSD) facility. Also, equipment used in the excavation process must be adequately decontaminated and all waste materials produced as a result of the decontamination procedures disposed in accordance applicable State and federal requirements.

Solid waste that has been disposed illegally (unpermitted solid waste dumps or burial sites) may be encountered during construction activities and a variety of solid waste is generated during construction activity. Persons should contact the Alabama Department of Environmental Management Land Division if there are questions on how to proceed if illegal solid waste dumps or buried solid waste are encountered, or regarding proper management of solid waste generated during construction. Brownfield sites (see Glossary for definition) may have issues that call for unique approaches for remediation and or construction. The Alabama Department of Environmental Management Land Division provides oversight of

assessment and remediation activities concerning these types of sites through its Brownfield Redevelopment and Voluntary Cleanup Program.

Cultural Resources

Cultural resources that may be altered, disturbed or destroyed by project implementation should be reported. Cultural resources consist of prehistoric and historic archaeological sites and historic structures (bridges, objects, buildings, etc., 50 years or older). If a cultural resource is known to exist or is discovered during project implementation, the Alabama Historic Commission should be contacted immediately for further guidance. The Alabama Historical Commission also maintains a listing of Historic Districts and Historic Structures and is responsible for maintaining the Archaeological Site Files, a database that contains the locations and significance of previously recorded archaeological sites. Under normal circumstances, after a cultural resource has been recorded, the project will be allowed to proceed as planned.

Sensitive Waters

Waters that have been designated by the Alabama Department of Environmental Management for special emphasis (i.e. Tier 1) or protection (i.e. Outstanding Alabama Water) may require additional erosion and sediment control measures to provide a higher level of water quality protection than would otherwise be required. Also, additional requirements may be imposed by state regulations for review of plans before permits are issued.

Sites in Coastal Zone

Construction plans prepared for sites in the designated coastal areas of Alabama must comply with the guidelines contained in the Coastal Nonpoint Pollution Control Program (CNPCP). While the practices that are needed are similar to those needed throughout the state, except for the dune related practices, there are additional requirements related to permitting within this Coastal Management Area that influence the requirements for plan content. It is recommended that construction practices (including Detention, Retention and Bioretention) within the Coastal Area be designed to yield greater than 35% reduction in nutrients and a minimum of 80% reduction in total suspended solids (TSS). Another example of such a requirement is the construction of a Dune Sand Fence (DSF) which meets the guidance from the CNPCP office and the US Fish and Wildlife Service to benefit endangered and threatened sea turtles.

Stream Alterations

Streams, both perennial and intermittent, are considered “waters” of the United States and are regulated as “wetlands” under the Clean Water Act, Section 404 by the Army Corps of Engineers. Relocating streams or other modifications must be approved by the Corps of Engineers. In-depth guidance for obtaining approval for alterations of streams is beyond the scope of this handbook. Detailed information

should be obtained from the Army Corps of Engineers serving the area. Stream alterations also require a 401 Clean Water Certification from the Corps of Engineers. Alterations also require approval by the Alabama Department of Environmental Management under applicable rules of the department. Associated with streams are the nearby adjacent areas and local regulations involving buffer zones may prohibit or otherwise restrict disturbances and construction in these areas.

Wetlands

Construction plans must respect the wetland regulations of the Clean Water Act, Section 404, and all applicable Alabama Department of Environmental Management rules. While the details of the regulations are beyond the scope of this handbook, it must be noted that wetlands cannot be altered by dredging and filling except in small increments approved by the Army Corps of Engineers and, in addition, construction plans shall be prepared to prevent negatively impacting wetlands off-site.

Threatened and Endangered Species

Threatened and endangered species habitat that may be altered, disturbed or destroyed should be reported. If a Threatened and Endangered Species is found within the proposed work area, the U. S. Fish and Wildlife Service should be contacted for consultation before additional work proceeds.

Components of a Plan

This subtopic describes the typical components that should be included in a plan. Local or state regulations may require additional items or more detailed information than listed.

There are typically two components of a plan: a Site Plan Map showing locations of the planned practices and a Written Narrative. Supporting materials are essential to develop the plan and they should be a part of the associated file material available with the plan. In addition, additional components such as a site location map are needed or required to satisfy regulatory requirements.

Site Plan Map (Sometimes Referred to as Treatment Map)

This map may include a site development drawing and a site erosion and sediment control drawing depicting types and, to the extent possible, locations of planned practices. Map scales and drawings should be appropriate for clear interpretation. Site planners are urged to use the standard coding system for practices contained at the end of this chapter. Use of the coding system will result in increased uniformity of plans and better readability for plan reviewers, job superintendents, and inspectors statewide.

Written Narrative

As needed, additional information that is not included on the site plan map should be included in a plan narrative that is written in a clear, concise manner. Typical items to include are the planned measures. Other items that may be needed include (a) a construction schedule that provides information both on sequence and time of year for installing the various practices and measures, (b) information on maintaining the practices and measures during construction and after installation have been completed and (c) a schedule for regular inspections and repair of erosion and sediment control and stormwater measures during construction. In some instances, existing conditions at the site and adjacent areas and rationale for those decisions involved in choosing erosion and sediment control measures may be included to help clarify the plan.

Adequate information provided by the narrative is important for the plan reviewer, the construction superintendent and the inspector. These details help insure that erosion and sediment control and stormwater measures are understood and properly installed. In addition, other information may be required in the plan by the Alabama Department of Environmental Management and local governments. Much of the additional information is covered by the following section Supporting Materials and Supporting Data.

Supporting Materials (Referred to later in Chapter as Supporting Data)

These items include inventory information collected and used during the planning process (contour maps, soils maps, charts, or other materials as applicable used in evaluating the site and formulating the plan). Supporting materials are important to all those involved in plan formulation and plan reviews and should be available to those with a specific need for them.

Step-By-Step Procedures for Plan Development

The context of the procedures presented in this subtopic is that a professional skilled in erosion and sediment control and stormwater management will assist another professional that is developing the overall site plan.

Step 1- Data Collection

Data collection includes inventorying the existing site conditions to gather information which will help in developing the most effective erosion and sediment control plan. The information should be shown to the extent practical on a map and explained in well-organized notes. This information eventually becomes a part of Supporting Data and is used to analyze and evaluate the site and practice options.

Topography

A large-scale topographic map of the site should be prepared. The suggested contour interval is usually 1 to 2 feet depending upon the slope of the terrain. However, the interval may be increased on steep slopes.

Drainage Patterns

All existing drainage swales and patterns on the site should be located and clearly marked on the topographic map.

Soils

Major soil series on the site should be noted and shown on the topographic map if the information is available. Soils information for previously undisturbed sites can be obtained from the Web Soil Survey (see Appendix [Soils in Alabama](#)). On-site soils evaluations and borings can be provided by soil consultants. For ease of interpretation, soils information should be plotted directly onto the map or an overlay of the same scale.

Groundcover

The existing vegetation on the site should be determined. Such features as trees and other woody vegetation, grassy areas, and unique vegetation should be shown on the map or described in the notes describing the site. In addition, existing bare or exposed soil areas should be indicated. This information may be important in determining clearing limits and establishing stages of construction.

Adjacent Areas

Areas adjacent to the site should be inventoried and important features that may be impacted by the proposed plan should be marked on the topographic map or identified in the notes. Applicable features include streams, springs, sinkholes, roads, wells, houses, other buildings, utilities and other land areas.

Floodplain Boundaries

Floodplains should be determined. Sources of information include soil surveys available from the Natural Resources Conservation Service, topographic maps, flood insurance maps, and flood plain maps that are available from many municipalities.

Receiving Waters

The use classification and special designation of streams and lakes that receive stormwater from the proposed site should be determined. This information is available from the Alabama Department of Environmental Management.

Wetlands

Wetlands and other areas that are possibly wetlands should be identified. Wetlands may be quite apparent or there may be areas that are questionable. Maps developed as part of the National Wetlands Inventory, USGS topographic maps and soil surveys should be collected to evaluate an area for wetlands. Boundaries of wetlands must be delineated if wetlands exist on areas to be disturbed by construction.

Contaminated Sites

Trash, abandoned appliances, potential contaminated soil and hazardous waste or any other material that should not be on the site should be identified. Brownfields fit into this category.

Cultural Resources

If federal funds (grants or other directed federal funds) or federal property is involved, a cultural resources review or survey is required before any ground-disturbing activities may begin (Section 106, National Historic Preservation Act). On public and private lands, the Alabama Historical Commission is the primary state agency responsible for archaeological resources protection and maintains the State Archaeological Site Files. According to the Code of Alabama (Alabama Code), the State reserves the right to explore, excavate and survey prehistoric and historic sites. In addition to cultural resource regulations, there are laws protecting cemeteries and human remains (marked and un-marked); permits are required to excavate graves.

Threatened and Endangered Species

Threatened and endangered species that may exist in the area and their associated habitat should be considered. Lists containing both the species and their habitat characteristics are available from the local office of the Natural Resources Conservation Service.

Step 2- Data Analysis

When all of the data in Step 1 are considered, a picture of a site's potentials and limitations should emerge. The qualified design professional should be able to determine those areas which have potentially critical erosion hazards and the potential for construction disturbances to cause adverse offsite impacts. The following are some important points to consider in site analysis:

Topography

Topographic considerations are slope steepness and slope length and the longer and steeper the slope, the greater the erosion potential from surface runoff. Slope modifications with large cuts and fills may exacerbate the potential for erosion.

Drainage Patterns

Swales, depressions, and natural watercourses, should be evaluated in order to plan where water will concentrate and the measures that will be needed to maintain a stable condition for concentrated flow. Where it is possible, natural drainageways should be used to convey runoff over and off the site to avoid the expense and problems of constructing an artificial drainage system. Man-made ditches and waterways become part of the erosion and turbidity problem if they are not properly stabilized. Potential for flooding and possible sites for stormwater detention basins, sediment basins and low impact features such as rain gardens should be determined.

Soils

Soil properties such as depth to bedrock, depth to seasonal high water table, permeability, shrink-swell potential and texture should exert a strong influence on development decisions. Also, the flood hazard related to the soils can be determined based on the relationship between soils and flooding. The Web Soil Survey (see Appendix Soils in Alabama) is a source of information on the soil series of Alabama.

Groundcover

Groundcover is the most important factor in preventing erosion. Any existing vegetation which can be saved will help prevent erosion. Trees and other vegetation protect the soil as well as beautify the site after construction. Therefore, it is important to recognize vegetation that can be retained during, and possibly after construction, to assist in stabilizing the site.

Adjacent Areas

The analysis of adjacent properties should focus on areas downslope, upslope and downstream from the construction project. The potential for sediment deposition on adjacent properties because of construction-related erosion should be analyzed so that appropriate erosion and sediment control measures can be planned. Obviously, the potential for impacting streams with turbidity must be considered. In some instances, water that enters the site from upslope should be diverted to minimize the potential for site related problems involving erosion, sediment, and turbidity.

Floodplains

Floodplains are generally restrictive in nature and the uses planned within them must be consistent with local regulations. The location of facilities within floodplains should usually be avoided to prevent restriction of flood flows and potential changes in peak flood stages downstream.

Receiving Waters

Watercourses which will receive direct runoff from the site should be of major concern: these streams should be analyzed to determine their use classification and

if they have a sensitive water designation. The potential impact from sediment and turbidity pollution on these watercourses should be considered as well as the potential for downstream channel erosion due to increased velocity of stormwater runoff from the site.

Wetlands

Wetlands or the absence of wetlands should be determined by a qualified professional. Wetland boundaries should be clearly marked by a wetland delineator to provide a distinct location and boundary to use during the planning, design and construction phases of a project.

Waste Materials

Sites with known or potential contamination by petroleum, chemical spills, etc. should have a thorough assessment conducted by a qualified professional and result in a comprehensive site assessment. Details of this activity are beyond the scope of this handbook. The Alabama Department of Environmental Management should be contacted for assessment procedures.

Cultural Resources

The presence of cultural resources within the area of potential effect (includes the immediate project area and any off-site areas, such as borrow pits, fill disposal or temporary storage areas, and equipment staging areas) should be considered. Care should be taken to avoid disturbing cultural resources; previously unknown or undocumented cultural resources should be reported to the Alabama Historical Commission.

Threatened and Endangered Species

Habitat for threatened and endangered species (TES) should be evaluated. If potential exists for occurrence of TES a determination of their occurrence should be made by a qualified professional.

Step 3-Facility Plan Development

This step applies to sites that are in the planning stage where planning of the facilities have not been firmly determined. After analyzing the data about the site and determining any site limitations, the erosion and sediment control professional can assist the professional developing the overall site plan formulate a site plan that is in harmony with the conditions unique to the site. An attempt should be made to locate the buildings, roads, and parking lots and develop landscaping plans to utilize the strengths and overcome the limitations of the site. *Ideally, there can be flexibility in the location of facilities and low-impact development concepts will be strongly considered.* The following are some points to consider in making these decisions:

- Fit development to terrain. The development of an area should be tailored, as much as possible, to existing site conditions. For example, confine construction activities to the least critical areas. This will avoid unnecessary land disturbance while minimizing the erosion hazards and development costs, including cost of erosion and sediment control.
- Cluster buildings together. This minimizes the amount of disturbed area, concentrates utility lines and connections while leaving more open natural space. The cluster concept not only lessens the erodible area, but it generally reduces runoff and development costs.
- Minimize impervious areas. Keep paved areas such as parking lots and roads to a minimum. This goes hand in hand with cluster developments in eliminating the need for duplicating parking areas, access roads, etc. The more land that is kept in vegetative cover, the more water will infiltrate thus minimizing runoff and erosion. Consider the use of special paving products which will allow water to infiltrate or cellular blocks which have soil and vegetation components.
- Utilize the natural drainage system. If the natural drainage system of a site can be preserved instead of being replaced with storm sewers or concrete channels, the potential for downstream damages due to increased runoff can be reduced.
- Determine if there are any “environmentally sensitive” areas (areas of special concern), to be protected during and after project implementation. In general, most erosion and control projects will have an overall beneficial effect to cultural resources since they would be protected from further environmental degradation.

Step 4-Planning for Erosion and Sediment Control and Stormwater Management

After the site facility plan layout has been developed, a plan is developed to minimize erosion on-site and delivery of sediment and turbid water off-site. Additional objectives may include those related to increased peaks and runoff associated with a development, flood control and off-site erosion control.

The following procedure is recommended for formulating the system of practices and measures for erosion and sediment control and stormwater management.

- Divide the site into drainage areas. Determine how runoff will travel over the site.
- Determine limits of clearing and grading. Decide exactly which areas must be disturbed in order to accommodate the proposed construction. Pay special attention to critical areas which can be avoided (areas with high potential for erosion and needing special treatment if disturbed). The important point in this activity is to minimize the areas to be disturbed.

- Select erosion and sediment control and stormwater management practices and measures using a systems concept. Practices and measures should be selected that are compatible and, as a system, can be expected to meet objectives for the development or activity.

Consider how erosion and sediment can be controlled in each small drainage area of the entire site. Remember, it is easier to control erosion than to contend with sediment after it has been carried downslope and downstream.

Plan to sequence construction so that no area remains exposed for unnecessarily long periods of time. On large projects, stage the construction, if possible, so that one area can be stabilized before another is disturbed. Sequencing and staging may influence the choice of practices.

The practices and measures in this Handbook are divided into 6 descriptive categories that relate to their functions: site preparation, surface stabilization, runoff conveyance, sediment control, stormwater management, and stream protection. Other categories that are sometimes used, such as vegetative, structural and management measures, are imbedded into the 6 categories.

Again, review each drainage area, determine the categories that apply and select practice(s) to comprise a technically sound and cost-effective system.

- **Site Preparation** (Construction Exit Pad, Land Grading, and Topsoiling)

Construction Exit Pad should be planned for early installation at each access point that vehicles will leave the disturbed area of a construction site and enter a public road. The stockpiling of topsoil should be done as an initial part of earthmoving. Most sites have enough topsoil available for stockpiling to provide adequate amounts for topsoiling the areas to be established to permanent vegetation. Land grading techniques can be done to compliment erosion control systems by timing of grading specific areas and surface roughening areas which may involve what is referred to in the Southeastern United States as “tracking”.

- **Surface Stabilization** (Chemical Stabilization, Dune Sand Fence, Dune Vegetation Planting, Dune Walkover, Dust Control, Erosion Control Blanket, Groundskeeping, Mulching, Preservation of Vegetation, Temporary Seeding, Permanent Seeding, Retaining Wall, Shrub, Vine and Groundcover, Sodding, and Tree Planting on Disturbed Areas)

Most qualified design professionals agree that vegetative measures should be maximized to provide as much erosion and sediment control as possible. Structural measures are generally more costly than vegetative controls but they are necessary on areas where vegetation and reinforcement with erosion control blankets or chemical measures will not provide adequate erosion control. Temporary practices from this category are needed on

most sites and final stabilization of all landscapes requires one or more practices from this category.

- **Runoff Conveyance** (Check Dam, Diversion, Drop Structure, Grass Swale, Lined Swale, Outlet Protection, Riprap-Lined Swale, Subsurface Drain, and Temporary Slope Drain)

Diversions are particularly important in (1) diverting clean water away from a disturbed site (2) in preventing flows from eroding cut and fill slopes and (3) in breaking (shortening) slope lengths. The other practices in this category are needed to safely move concentrated flows of stormwater in channels. Concentrated flows are the potential cause of gullies and the runoff conveyance practices are used to prevent gully erosion. Subsurface drains are used to facilitate another practice, such as Grass Swale, in becoming successfully established and maintained. One or more practices from this category are needed on sites with channel flow.

- **Sediment Control** (Brush/Fabric Barrier, Filter Strip, Floating Turbidity Barrier, Flocculant, Inlet Protection, Rock Filter Dam, Sediment Barrier, Sediment Basin, and Sediment Trap)

Sediment control practices function primarily on the basis that sediment laden water will deposit at least part of its load while the water is ponded on the construction site by the practice. Flocculant is recognized for its value in both capturing sediment and in turbidity control. All of the sediment control practices are considered temporary. The effectiveness of each practice is dependent upon the unique attribute of the practice, the texture of the sediment in suspension and suspension time.

- **Stormwater Management** (Bioretention Area, Porous Pavement, and Stormwater Detention Basin)

Stormwater management practices detain or retain stormwater on the construction site. These practices are designed to minimize stormwater runoff. Stormwater Management in Chapter 2 describes the planning considerations for stormwater management. Local regulations address the requirements for projects that are under their jurisdiction. Even where stormwater detention is not required by regulations, the qualified design professional should determine if detention is needed based on potential impacts. Low impact development measures that slow runoff and increase infiltration, such as bioretention areas and additional green space can contribute significantly to reducing peaks and volume of runoff. Additional low impact practices are found in the Low Impact Development Handbook for the State of Alabama. If significant storage is needed on-site a stormwater detention basin may be used and, for an additional temporary benefit, retrofitted as a sediment basin to address sediment and turbidity issues.

- **Stream Protection** (Buffer Zone, Channel Stabilization, Stream Diversion Channel, Streambank Protection, and Temporary Stream Crossing)

These stream protection practices are primarily intended to be used to preserve or repair streams. Designing new channels is beyond the scope of this handbook. One or more of these practices should be considered essential where a construction project includes a perennial or intermittent stream.

Step 5-Plan Assembly

The final step of plan development consists of compiling and consolidating the pertinent information into a site-specific plan for erosion control, sediment control and stormwater management. The major plan components are a narrative and a site plan map. Supporting data is assembled to substantiate planning options considered and developed and to aid in review of a plan. For a plan to be effective the works that are planned must reflect what is needed for the site, the planned works must be understood and accepted by the developer, and the document must be presented so clearly that the contents be contracted and constructed to meet developer and environmental objectives.

The following checklist may be used in assembling the narrative and site plan map to be sure all major items are included.

Checklist for Plans

Narrative

Explain the solutions for existing and predicted problems in the narrative (tables and charts may be used to display information in a format that is easier to understand).

Project Description

Briefly describe the nature and purpose of the land disturbing activity and the amount of disturbance involved.

Practices and Measures

Identify the practices and methods which will be used to control erosion on the site, prevent or minimize sediment from leaving the site, and address turbidity and hydrologic changes associated with the proposed project. Sequence and staging of construction activities to minimize disturbance and erosion should be addressed.

Inspections

Prescribe a schedule for inspections and repair of practices.

Maintenance

Include statement(s) explaining how the project will be maintained during construction until final stabilization. In some instances, maintenance that will be needed after construction should be included.

Site Plan Map

The site plan map is one or a series of maps or drawings pictorially explaining information contained in the narrative.

Site Plan Label

The label should include the name of owner, name of site or facility, county name, location (township, range and section) name of qualified design professional, and date plan made, and if applicable, date of latest revision.

Existing Contours

The existing contours of the site should be shown on a map (the scale used for this map should be of sufficient scale for meaningful evaluations). The scale of the site plan may range from 1" = 100 feet to 1" = 20 feet.

Existing Vegetation

The existing tree lines, grassy areas, or unique vegetation should be shown on a map.

North Arrow

The direction of north in relation to the site should be shown. The top of all maps should be north, if practical.

Existing Drainage Patterns

The dividing lines and the direction of flow for the different drainage areas should be shown on a map.

Final Contours

Planned contours should be shown on a map.

Development Features

The outline of buildings, roads, drainage appurtenances, utilities, landscaping features, parking areas, improvements, impervious areas, topographic features, and similar man-made installations should be shown to scale and relative location.

Limits of Clearing and Grading

Areas which are to be cleared and graded should be outlined on a map.

Wetlands

The location of wetlands is important and should be shown accurately and preferably on the site map

Cultural Resources

The locations of cultural resources should be shown accurately on the plan map and construction plans. Their location is essential if these areas are to be avoided or protected during project construction.

Location of Practices and Legend

The locations of the erosion and sediment control and stormwater management practices planned for the site should be shown on a map. A combination of symbols and acronyms are used to identify the practices. A list of the acronyms is included at the end of this chapter under “Legend of Measures for Erosion and Sediment Control and Stormwater Management.”

Site Location or Vicinity Map (if required by regulatory agency)

Provide a small map locating the site in relation to the surrounding area. A portion of a 7.5 minute series U.S.G.S. topographic map that covers the project area usually meets this requirement.

Supporting Data (relevant materials collected and generated during all stages of planning).

Existing Site Conditions

This material describes the existing topography, vegetation, and drainage.

Adjacent Areas

This material describes the adjacent and neighboring areas such as streams, lakes, residential areas, roads, etc., which might be affected by the land disturbance.

Soils

Include a brief description of the soil series on the site giving relevant information such as erodibility, permeability, depth, texture, and any other limitations. The boundaries of the different soils should be shown on a map.

Critical Areas

Identify and describe areas on the site which will need special treatment to prevent serious erosion, i.e., cut and fill slopes.

Areas of Special Concern

Include relevant information affecting planning in the Coastal Zone Program area, contaminated soils, new or innovative practices, stream alterations, wetlands, impaired waters, and cultural resources. If federal lands or federal funds are involved, a letter from the lead federal agency stating that there would be no adverse effect to cultural resources and allowing the project to proceed as planned or amended will be required; a similar letter from the Alabama Historical Commission may be necessary if cultural resources are present on State and private lands.

Calculations and Design Data Needed During Planning

Include estimates used to evaluate practices that are chosen based on peak flows, acres of runoff, erosion rates, erosion control options, etc.

Legend of Measures for Erosion and Sediment Control and Stormwater Management

Site Preparation

- (CEP) Construction Exit Pad
- (LG) Land Grading
- (TSG) Topsoiling

Surface Stabilization

- (CHS) Chemical Stabilization
- (DSF) Dune Sand Fence
- (DVP) Dune Vegetation Planting
- (DW) Dune Walkover
- (DC) Dust Control
- (ECB) Erosion Control Blanket
- (GK) Groundskeeping
- (MU) Mulching
- (PS) Permanent Seeding
- (PV) Preservation of Vegetation
- (RW) Retaining Wall
- (SVG) Shrub, Vine and Groundcover Planting
- (SOD) Sodding
- (TS) Temporary Seeding
- (TP) Tree Planting on Disturbed Areas

Runoff Conveyance

- (CD) Check Dam
- (DV) Diversion
- (DS) Drop Structure
- (GS) Grass Swale
- (LS) Lined Swale
- (OP) Outlet Protection
- (RS) Riprap-lined Swale
- (SD) Subsurface Drain
- (TDS) Temporary Slope Drain

Sediment Control

- (BFB) Brush/Fabric Barrier
- (FS) Filter Strip
- (FB) Floating Turbidity Barrier
- (FL) Flocculant
- (IP) Inlet Protection
- (RD) Rock Filter Dam
- (SB) Sediment Barrier
- (SBN) Sediment Basin

Stormwater Management

- (BA) Bioretention Area
- (PP) Porous Pavement
- (SDB) Stormwater Detention Basin

Stream Protection

- (BZ) Buffer Zone
- (CS) Channel Stabilization
- (SDC) Stream Diversion Channel
- (SP) Streambank Protection
- (TSC) Temporary Stream Crossing

Chapter 4

Best Management Practices Design

Site Preparation

Construction Exit Pad (CEP).....	65
Land Grading (LG).....	69
Topsoiling (TSG).....	73

Surface Stabilization

Chemical Stabilization (CHS).....	79
Dune Sand Fence (DSF).....	81
Dune Vegetation Planting (DVP).....	85
Dune Walkover (DW).....	93
Dust Control (DC).....	97
Erosion Control Blanket (ECB).....	101
Groundskeeping (GK).....	109
Mulching (MU).....	115
Permanent Seeding (PS).....	121
Preservation of Vegetation (PV).....	131
Retaining Wall (RW).....	141
Shrub, Vine and Groundcover Planting (SVG).....	143
Sodding (SOD).....	153
Temporary Seeding (TS).....	159
Tree Planting on Disturbed Areas (TP).....	165

Runoff Conveyance

Check Dam (CD).....	171
Diversion (DV).....	179
Drop Structure (DS).....	185
Grass Swale (GS).....	189
Lined Swale (LS).....	195
Outlet Protection (OP).....	201
Riprap-lined Swale (RS).....	213
Subsurface Drain (SD).....	219
Temporary Slope Drain (TSD).....	225

Sediment Control

Brush/Fabric Barrier (BFB).....	231
Filter Strip (FS).....	235
Floating Turbidity Barrier (FB).....	241

Flocculant (FL)	249
Inlet Protection (IP)	255
Rock Filter Dam (RD).....	263
Sediment Barrier (SB).....	267
Sediment Basin (SBN)	275
Stormwater Management	
Bioretention Area (BA	293
Porous Pavement (PP)	303
Stormwater Detention Basin (SDB).....	307
Stream Protection	
Buffer Zone (BZ)	315
Channel Stabilization (CS)	319
Stream Diversion Channel (SDC)	325
Streambank Protection (SP).....	331
Temporary Stream Crossing (TSC).....	343

Construction Exit Pad (CEP)



Practice Description

A construction exit pad is a stone base pad or manufactured product designed to provide a buffer area where mud and caked soil can be removed from the tires of construction vehicles to avoid transporting it onto public roads. This practice applies anywhere traffic will be leaving a construction site and move directly onto a public road or street.

Planning Considerations

Roads and streets adjacent to construction sites should be kept clean for the general safety and welfare of the public. A construction exit pad (Figure CEP-1) should be provided where mud can be removed from construction vehicle tires before they enter a public road.

Where possible the construction exit pad should be located and constructed at a site where surface runoff from the pad will not transport sediment from the pad off the site. If the pad slope toward the road exceeds 2%, a diversion ridge 6" to 8" high with 3:1 side slopes should be constructed across the foundation approximately 15 feet from the entrance. This diversion ridge should divert surface runoff from the pad away from the road and into a sediment trap or basin.

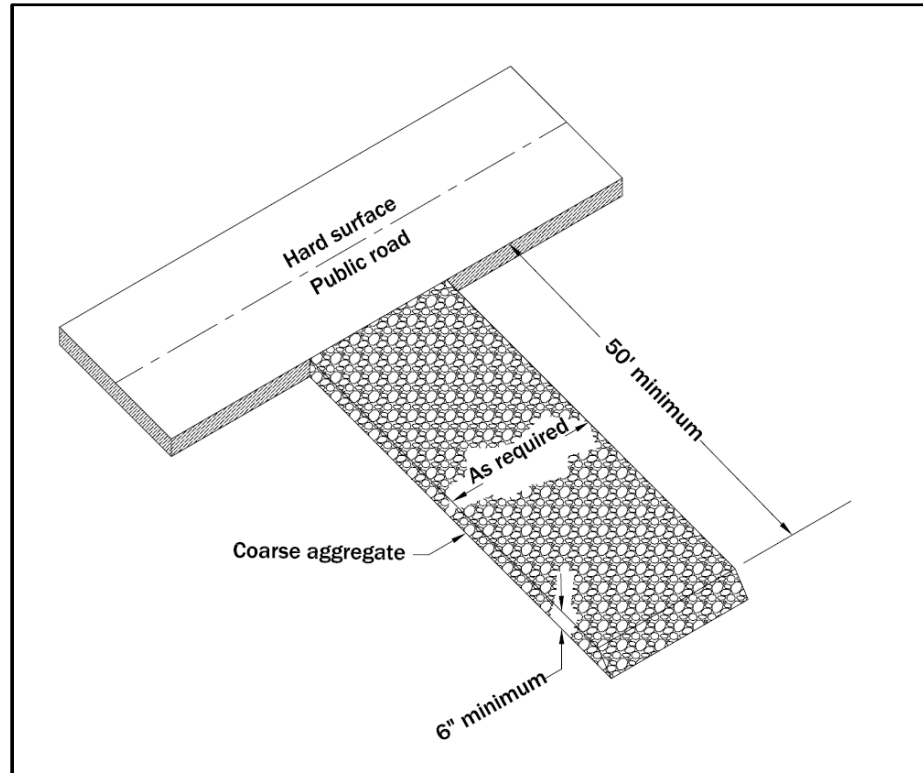

Figure CEP-1 Gravel Construction Exit

If the action of the vehicle traveling over the gravel pad does not sufficiently remove the mud or if the site is in a particularly sensitive area, a washing facility should be included with the pad (Figure CEP-2). When a washing facility is required all wash water shall be diverted to a sediment trap or basin.

If the construction exit pad is located in an area with soils that will not support traffic when wet, an under liner of geotextile will be required to provide stability to the pad.

Construction of stabilized roads throughout the development site should be considered to lessen the amount of mud transported by vehicular traffic. The construction exit pad should be located to provide for maximum use by construction vehicles.

Consideration should be given to limiting construction vehicles to only one ingress and egress point. Measures may be necessary to make existing traffic use the construction exit pad.

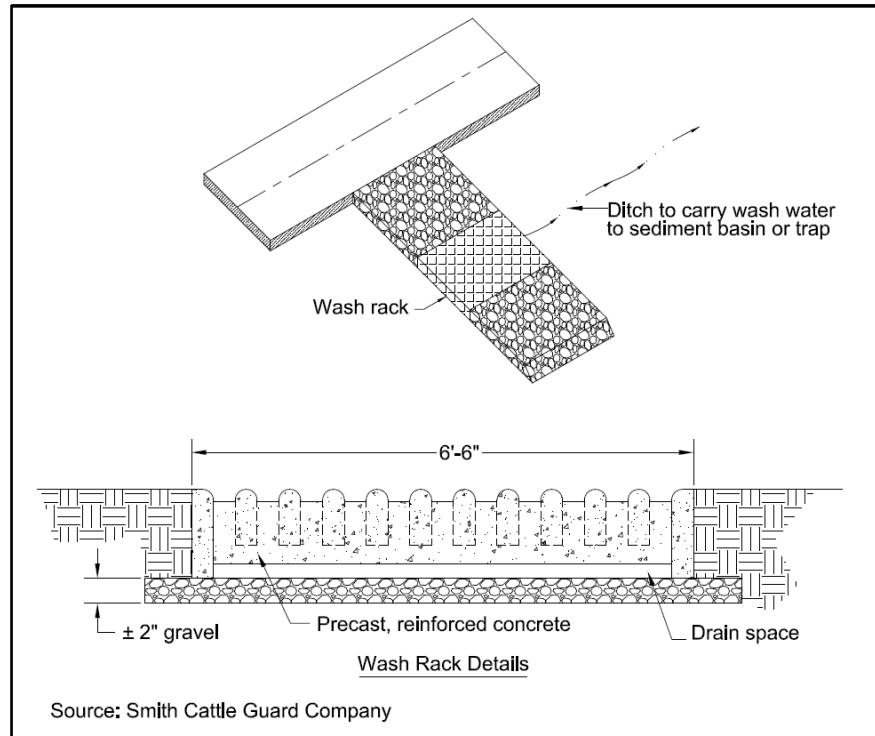

Figure CEP-2 Construction Exit with Wash Rack

Design Criteria

Aggregate size

Aggregate should be Alabama Department of Transportation coarse aggregate gradation No.1.

Pad Thickness

The exit pad shall have a minimum aggregate thickness of 6”.

Geotextiles

A non-woven geotextile shall be placed underneath the aggregate. The geotextile shall be of the strength and durability required for the project to ensure the aggregate and soil base are stable. Generally, the non-woven geotextile should meet the requirements for a Class 2 geotextile used for separation that is found in the current version of AASHTO M288.

Pad Length

The exit pad should provide for entering and parking the longest anticipated construction vehicles. A pad is typically 50 feet long, but the required length may be longer or shorter.

Pad Width

The exit pad width is typically 20 feet but may be narrower or wider to equal the full width of the vehicular egress.

Washing

A washing facility shall be provided if necessary to prevent mud and caked soil from being transported to public streets and highways. It shall be constructed of concrete, stone, and/or other durable materials. Provisions shall be provided for the mud and other material to be carried away from the washing facility to a sediment trap or basin to allow for settlement of the sediment from the runoff before it is released from the site.

Land Grading (LG)



Practice Description

Land grading is reshaping of the ground surface to provide suitable topography for buildings, facilities, and other land uses, to control surface runoff, and to minimize soil erosion and sedimentation both during and after construction. This practice applies to sites where the existing topography must be modified to prepare for another land use, or where adapting proposed development to the existing landscape can reduce the erosion potential of the site and the cost of installing erosion and sediment control measures. In some instances, other practices such as diversions or benches can be used to reduce the length of continuous slopes and reduce erosion potential.

Planning Considerations

A detailed plan should be developed by a qualified design professional for all land grading activities at the project site. The plan should show all areas to be disturbed, the areas of cut, areas of fill, and the finished elevation for all graded areas. Areas that will be mowed after the site is developed should have slopes planned that are not too steep for the type of mowing equipment that will be used for regular maintenance.

The grading plan should be designed to protect existing vegetation where possible, especially around natural drainageways. Grading activities should be scheduled to minimize the area disturbed at any one time during the construction process. The plan should include provisions for stabilizing disturbed areas immediately after final grading is completed. Provisions should also be made to protect existing

underground utilities. Finally, topsoil should be removed and stockpiled for use in revegetating the site.

The grading plan should also include necessary practices for controlling sediment and erosion at the site. These practices could include stable outlets and slope breaks such as diversions or benches.

Design Criteria

Site Preparation

A detailed survey of the construction site should be performed by a qualified surveyor prior to grading plan development. This survey should include existing topographic information at the site including existing elevations, existing drainage patterns, locations of existing overhead and underground utilities, and construction limit boundaries.

The grading plan should require that the existing topsoil at sites to be graded be removed as the first step in the grading process. The plan should include a location on the construction site where topsoil will be stockpiled. Stockpiled topsoil should be protected by temporary vegetation (see Temporary Vegetation practice) or other appropriate temporary cover, such as plastic, until it is used to cover disturbed areas in advance of permanent vegetation of the site.

The grading plan should include a schedule of disturbance activities that minimizes the area disturbed at any point in time using sequencing and staging concepts. In areas where clearing of existing vegetation is planned, the area should be cleared and grubbed by removing trees, vegetation, roots, and other debris such as trash. In areas to be filled all loose or weak soil and oversized rocks should be removed from the area. The foundation of the area to be filled should consist of soil or rock material of adequate strength to support the proposed fill material and the structures to be built at the site. The exact depth of material to be removed should be determined by a qualified geotechnical professional according to accepted engineering standards.

Grading

A plan for placement of fill should be developed by a qualified geotechnical professional. The plan should specify the source of fill materials, which should be obtained on site if possible. Materials used for fill, when placed according to the plans and specifications, should provide sufficient strength to support structures planned for construction at the location.

Loose fill material should be placed in layers not exceeding 9" in thickness. The materials should be compacted at a moisture content and to a dry density that will produce the design bearing strength required for structures planned at the site. A qualified geotechnical engineer should provide fill placement specifications using standard accepted engineering practices.

Long and/or steep slope lengths can result in increased rill and gully erosion potential. Erosion on these type slopes can be minimized by breaking the slope with diversions or benches (see Diversion practice). Diversion widths should be compatible with the expected maintenance equipment. Care is needed in locating outlets that will be stable and not cause gully erosion. The following table gives general guidance on the horizontal spacing of slope breaks:

Table LG-1 Guidelines for Spacing Slope Breaks ¹

Slope (H:V)	Horizontal Spacing (Ft)
1:1	20
2:1	40
3:1	60
4:1 and 5:1	80
6:1 to 9:1	120
10:1 or flatter	200

¹ Adjustments in spacing may be made to account for soil and site conditions and professional experience of the site designer.

In areas where seepage and ground water are present subsurface drains should be installed to improve slope stability or soil bearing capacity (see Subsurface Drain practice).

Steep slopes should be avoided if possible. Slopes that are to be vegetated should be 2 horizontal to 1 vertical or flatter. If the slope is to be maintained by tractor or other equipment the slope should be 3 horizontal to 1 vertical or flatter. Slopes should be designed to blend with surrounding topography as much as possible.

Erosion Control

The grading plan should include provisions for stabilization of graded areas immediately after final grading is completed. On areas that will have no additional disturbance, permanent vegetation should be applied immediately to the site (see Permanent Seeding practice) if grading is finished during the planting season. If grading is finished outside of the recommended planting dates a temporary cover should be installed using a Temporary Seeding or other appropriate cover and the Permanent Seeding planned for the next planting period. On areas where work is to be interrupted or delayed for 14 calendar days or longer, such as topsoil stockpiles, the area should be stabilized using mulch or temporary seeding (see Mulching or Temporary Seeding practice). Other stabilization measures such as hydraulic mulch or erosion control blankets should be used in extreme conditions, such as steep slopes and channels.

Where practical, runoff from undisturbed off-site areas should be diverted around the construction site to prevent erosion on the disturbed areas (see Diversion practice).

Sediment Control

Required sediment control practices should be installed before the land disturbance activities in the drainage area of the sediment control practices. Until disturbed areas can be stabilized, appropriate sediment control measures will be maintained to minimize sediment delivery off-site. Measures should include as a minimum:

- Sediment Barriers – Placed along toes of slopes (see Sediment Barrier practice).
- Sediment Basins – Divert sediment laden runoff to basins as needed to minimize off-site sedimentation and turbidity (see Sediment Basin practice).
- Inlet Protection – Where sediment-laden runoff is diverted to on-site stormwater drain inlets, the inlets should be protected with an appropriate sediment control practice.
- Stabilized Outlets – All runoff from the site should be conveyed in stabilized channels (see Grassed Swale, Lined Swale, Rip-rap Lined Swale, or other appropriate channel stabilization).

Topsoiling (TSG)



Practice Description

Topsoiling is the removal of a desirable soil surface, referred to as topsoil, at a site prior to construction and using it on areas to be vegetated. Topsoiling a site usually improves the quality of the plant growth medium at the site and increases the likelihood of successful plant establishment and performance. This practice applies to sites that are to be disturbed by excavation, compaction, or filling, and to other areas where the subsoil is unsuitable for plant growth.

Planning Considerations

Topsoil is the surface layer of the soil profile, generally characterized as darker than the subsoil due to enrichment with organic matter. It is the major zone of root development and biological activity. Microorganisms that enhance plant growth thrive in this layer. Topsoil can usually be differentiated from subsoil by texture as well as color. Clay content usually increases in the subsoil.

The depth of topsoil found on an undisturbed site may be quite variable over the proposed construction area because different soils have various depths of the surface layer. On severely eroded sites the original topsoil may be non-existent with the previous subsoil now occupying the surface.

Advantages of topsoil include its relatively high organic-matter content and friable consistency (soil aggregates can be crushed with only moderate pressure), and its

available water-holding capacity and nutrient content. Most often it is superior to subsoil in these characteristics. The texture and friability of topsoil are usually much more conducive to seedling emergence and root growth. In addition to being a better growth medium, topsoil is often less erodible than subsoil because it has less clay and more organic matter and the coarse texture of topsoil increases infiltration capacity and reduces runoff.

When properly limed, fertilized, and loosened, subsoils may provide a good growth medium especially if there is adequate rainfall or irrigation water to allow root development in otherwise high-density material. However, in most instances topsoiling should be used to provide the best opportunity for successful establishment and sustainability of the planned vegetative cover.

Topsoiling is strongly recommended where ornamental plants or high-maintenance turf will be grown. Topsoiling is a recommended procedure when establishing vegetation on shallow soils, soils containing potentially toxic materials, and soils of critically low pH (high acid) levels.

If topsoiling is to be done, the following items should be considered:

- An adequate volume of topsoil should exist on the site or be available locally. Topsoil will be spread at a lightly compacted depth of 4" or greater.
- Locate the topsoil stockpile so that it meets specifications and does not interfere with work on the site, block drainage or release appreciable amounts of sediment.
- Allow sufficient time in scheduling for topsoil to be spread and bonded prior to seeding, sodding, or planting.
- Take care not to apply topsoil to subsoil if the two soils have contrasting textures without disking or chiseling to create a favorable interface and bond. Sandy topsoil over clayey subsoil without disking or chiseling is a particularly poor combination, as water creeps along the junction between the soil layers and on steep slopes may cause the topsoil to slough.

Design Criteria

Materials

Field evaluation of the site should be made to determine if there is sufficient surface soil of good quality to justify stripping. Topsoil shall be friable and loamy (loam, sandy loam, silt loam, sandy clay loam, and clay loam). It shall be relatively free of debris, trash, stumps, rocks, roots, and noxious weeds, and shall give evidence of being able to support healthy vegetation. It shall contain no substance that is potentially toxic to plant growth.

Topsoil should meet the following criteria:

- pH range should be from 6.0-7.0. If pH is less than 6.0, lime should be added in accordance with soil test results or in accordance with the recommendations of the vegetative establishment practice being used.
- If additional off-site topsoil is needed, it should meet the standards stated above.
- The depth of material meeting the above qualifications should be at least 4". Soil factors such as rock fragments, slope, depth to water table, and layer thickness affect the ease of excavation and spreading of topsoil.

Generally, the upper part of the soil, which is richest in organic matter, is most desirable; however, material excavated from deeper layers may be worth storing if it meets the other criteria listed above.

Stripping

Strip only those areas that will be affected by construction or development. A normal stripping depth is 4-6" but deeper depths may be satisfactory if the soil is suitable and undercutting is allowable in locations such as buildings, water impoundment structures, roadways, etc. Appropriate sediment control measures such as sediment barriers, sediment basins, inlet protection, etc., should be in place before the topsoil is stripped. Stripping should not be done on areas intended to support conventional on-site effluent disposal lines (field lines).

Stockpiling

The stockpile location should be out of drainageways and traffic routes. Stockpiles should not be placed on steep slopes where undue erosion will take place. Measures should be taken to prevent erosion of the stockpiles. These would include:

- Mulching the stockpile when it is left inactive for over 13 days.
- Planting temporary vegetation when the stockpile is to be inactive over 30 days.
- Covering the stockpile with plastic whenever the piles are small and any soil loss would provide sediment to damage existing buildings or facilities or enter waters.
- Planting permanent vegetation when the stockpile use will be inactive over 12 months.
- In cases where the stockpile is small and will be removed in less than 14 days, it may be more practical to use a sediment barrier than an erosion control practice.

Site Preparation

Areas to be covered with topsoil shall be excavated, graded, filled, and shaped to the proper lines, grades and elevations before topsoil placement is started.

The subgrades should be checked for pH and limed if it is less than 6.0. Liming shall be done in accordance with soil tests and in relation to the seeding mixture to be planted. Incorporate lime to a depth of at least 2" by disking.

Applying Topsoil

The subsoil should be disked or chiseled to a depth of 2" or more to enhance bonding of the subsoil and topsoil immediately before placement of topsoil. Topsoil should be uniformly spread to a minimum compacted depth of 4". Required volumes of topsoil may be determined using Table TSG-1.

Table TSG-1 Volume of Soil Needed for Topsoiling

Depth to Spread (inches)	Cubic Yards Per 1,000 Sq. Ft.	Cubic Yards Per Acre
1	3.1	134
2	6.2	268
3	9.3	403
4	12.4	537
5	15.5	672
6	18.6	806

When applying topsoil, maintain needed erosion control practices such as diversions, grassed swales, lined swales, etc. Topsoil should not be spread when it or the subgrade is frozen or muddy.

Precautions should be taken to prevent layering of the topsoil over the subsoil by subsoiling or disking.

Settling of the topsoil is necessary to bond the soils together, but excessive compaction should be prevented. Light compaction is necessary to increase soil strength, reduce erosion, and enhance vegetation establishment.

Excessive compaction should be avoided as it increases runoff and inhibits seed germination and root development.

Surface irregularities that would impede surface drainage, increase erosion, or otherwise damage the site should be removed in final grading.

This Page Intentionally Left Blank

Chemical Stabilization (CHS)



Photo courtesy of Sunshine Supplies, Inc.

Practice Description

Chemical Stabilization erosion control involves the use of products, including soil binders that help to hold the soil in place, thereby reducing soil particle detachment and short-term erosion caused by water and wind. Water-soluble polyacrylamide (PAM) is often used for this purpose. Other products may also provide this benefit. The products are typically applied with temporary seeding and or mulching on areas where the timely establishment of temporary erosion control is so critical that seeding and mulching need additional reinforcement.

Planning Considerations

Chemical Stabilization products for surface stabilization are available in different formulations and should be used in combination with other Best Management Practices. The use of seed and mulch should be considered for providing erosion protection beyond the life of the chemical or soil binder. If the area where Chemical Stabilization products have been applied is disturbed, the application will need to be repeated.

Following are additional considerations to enhance the use of or avoid problems:

- Use recommended setbacks (Buffer Zone) when applying near natural water bodies.
- Application delays between product mixing and application as well as ultraviolet light exposure may decrease the performance of some products.

- Products are generally not effective in concentrated flow areas.
- Seeded areas will also need mulch.
- It is important to closely follow manufacturer's recommendations on application procedures.
- Do not use products in a way that will be toxic to aquatic organisms.
- Requests to use products not approved for Chemical Stabilization on permitted sites should be made to the state environmental agency.
- Erosion control effectiveness decreases with rainfall/runoff events.

Design Criteria

Application rates shall conform to manufacturer's guidelines for application.

The following specific criteria shall be followed:

- Chemical mixtures shall be environmentally benign, harmless to fish, wildlife, and plants, and shall be non-combustible.
- Users of chemical stabilization products shall follow all Material Safety Data Sheet requirements and manufacturer's recommendations. In the case of PAM, the use of a specific product should be based on the jar test with soil from the site and there should be appropriate measures at the site to ensure that PAM is not carried in stormwater emptying directly into natural waterbodies. This means that runoff should be flowing to settling sites such as sediment basins or sediment traps or be flowing over sites such as filter strips, straw or matting that serves as a collection site for the sediments.
- Additives such as fertilizers, solubility promoters or inhibitors, etc. to chemical stabilization products shall be non-toxic.
- The manufacturer or supplier shall provide written application methods. The application method shall ensure uniform coverage to the target and avoid drift to non-target areas including waters of the state. The manufacturer or supplier shall also provide written instructions to ensure proper safety, storage, and mixing of the product.

Dune Sand Fence (DSF)



Photo courtesy of Alabama Department of Environmental Management

Practice Description

A dune sand fence is a temporary barrier consisting of wooden slats installed across a dune landscape perpendicular to the prevailing wind. Dune sand fence reduces wind velocity at the ground surface and traps blowing sand. Sand fencing and appropriate planting materials can be used to build frontal ocean dunes to control beach erosion and flooding behind frontal dunes from wave over wash. Sand fence is applicable where sand can be trapped to enhance dune vegetation.

Planning Considerations

Coastal beaches are subject to regulations from a variety of Federal, State, and local agencies including the requirements of the state Coastal Nonpoint Pollution Control Program and Coastal Zone Management Programs. Permits or other approval procedures must be requested and granted by all appropriate jurisdictions before work is performed.

Coastal areas are affected by many dynamic systems. Detailed studies are often required to determine the possible effects that may result from dune modifications. Environmental assessments are generally required including public review and comment.

Plans should include details to install an additional set of fences over the existing fence until the barrier dune has reached a protective height. Dune sand fences must be constructed in such a manner that impacts to nesting endangered sea turtles are minimized.

Dune sand fences are components of dune erosion control systems and are most effective when used with other practices including Dune Walkover and Dune Vegetation Planting.

The specific location of a sand fence is based on professional knowledge and experience considering the factors that relate to natural dune establishment and sustainability.

Design Criteria

Scheduling

Attempt to install sand fencing during the recommended planting periods for the associated dune vegetation plantings that are planned.

Site Preparation

Determine if underground utilities exist on the site, mark their location, and locate fence lines and stakes to not damage the utilities.

Remove obstacles that will prevent installation of the sand fence before any work begins.

Installing the Dune Sand Fence

Erect the sand fences a minimum of 100 feet (horizontal distance) from the Mean High Tide (MHT) line with two parallel lines or rows of fence approximately 30 feet apart. The rows should be roughly parallel to the water line and be as close as possible to a right angle to the prevailing winds. See Figure DSF-1 for a plan view of a conceptual erosion and sediment control system.

As the fences fill with sand, an additional set of fences should be planned to be placed over those that are filled until the barrier dune has reached a protective height. To widen an old dune, fencing should be set seaward at 15 feet from its current base.

Materials

Use standard commercial 4-foot sand fences that consist of wooden slats wired together with spaces between the slats. The distance between slats is 1¼” or approximately equal to the slat width. The fence should be sound and free of decay, broken wire, and missing or broken slats.

The fence should be made from Grade A or better spruce with slats 1¼” wide and about 1¼” of space between laths or pickets. The 4-foot high fence should be woven between 5 two-wire cables of copper bearing, galvanized wire. The laths or pickets should be hot dipped in a red oxide weather resistant stain.

Wooden posts for fence support may be of pressure treated yellow pine or untreated black locust, red cedar, white cedar or other wood of equal life and strength. Use standard fence posts at least 7 feet long with a diameter of 3” to 4”.

Posts should be set at least 3 feet deep no further than 10 feet apart and not concreted in place. Four wire ties should be used to fasten the fence to the wood posts. Weave the fence between posts so that every other post will have fencing on the ocean side of posts. Tie wires should be no smaller than 12-gauge galvanized wire.

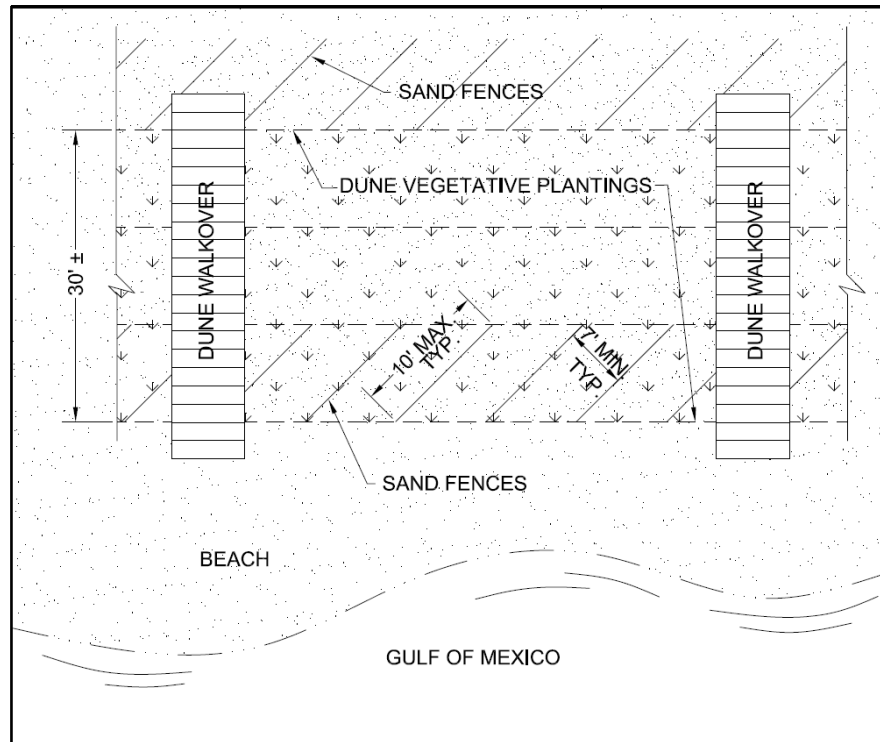

Figure DSF-1 Typical Dune Erosion Control System with Sand Fence

Construction Verification

Conduct inspections to determine that materials and installation meet plan specifications.

This Page Intentionally Left Blank

Dune Vegetation Planting (DVP)



Photo courtesy of Alabama Department of Environmental Management

Practice Description

Dune vegetation planting is the establishment of perennial vegetation on dunes from seed or vegetative material. Perennial dune vegetation provides economical long-term erosion control and helps prevent sediment from leaving the site. This practice is used where vegetation is desired and appropriate to permanently stabilize the dune. Additional measures, such as crosswalks and barriers, are often needed to develop successful establishment of the vegetation.

Planning Considerations

Coastal beaches are subject to regulations from a variety of Federal, State, and local agencies. Permits must be requested and granted by all appropriate jurisdictions before work is performed.

Protection of dunes from human and vehicular traffic is essential if vegetation is to succeed.

There are only a few plant species that are tolerant of the stresses of the beach environment. Plants must be able to survive burial by blowing sand, sand blasting, salt spray, saltwater flooding, drought, heat, and low nutrient supply.

Mulch usually used with other seedings (straw, hay, netting, peg and twine, and asphalt) is not recommended due to the difficulty in applying and anchoring the mulch and its untidy appearance.

Supplemental water (irrigation) is usually required during the first growing season to obtain good plant survival.

Design Criteria

Plant Materials

Use commercially available plant materials/varieties that are adapted in Alabama for coastal dune stabilization. See the section Measures for Stabilizing Coastal Dunes in Chapter 2, Table DVP-1 and the planting guides at the end of this practice for information to use in selecting plants.

Planting stock is available from commercial nurseries. Plants from 2-4" pots are generally adequate for most stabilization and building work. Smaller plants may be used on sites under ideal planting conditions or irrigation. Plants from pots larger than 4" are desirable only where aesthetics or traffic control is important, or erosion is extreme. Bare root stock dug from vigorous stands and planted when fresh gives survival and growth rates equal to potted materials. Unrooted stolons of bitter panicum may be cut after seed is mature and planted at 3 vertical cuttings per planting space or uncut stems in 3" to 4" deep furrows 12-18" apart. 'Atlantic' coastal panicgrass may be direct seeded at 15 pounds per acre, drilled or sowed in 2" deep furrows.

Table DVP-1 Commonly Used Plants for Dune Stabilization

Species	Plant Spacing	Preferred Planting Period*	Method
Sea Oats (<i>Uniola paniculata</i>)	12 – 36"	March 1-June 1	Potted plants
Atlantic Coastal Panicgrass (<i>Panicum amarum var-amarulum</i>)	12 – 36"	March 1- June 1	Seed or sprigs
Flageo Marshhay Cordgrass (<i>Spartina patens</i>)	12 – 24"	March 1- June 1	Sprigs
Sharpe Marshhay Cordgrass (<i>Spartina patens</i>)	12 – 24"	March 1- June 1	Sprigs
North PA Bitter Panicum (<i>Panicum amarum</i>)	24 – 36"	March 1- June 1	Potted plants or bare root plugs
South PA Bitter Panicum (<i>Panicum amarum</i>)	24 – 36"	March 1- June 1	Potted plants or bare root plugs

* See planting guide for each species for more details on planting dates.

Site Preparation

Tillage or liming is not required for planting on beach sand. Install the dune walkover, sand fences and the irrigation system prior to planting.

Planting Date

Plant vegetative material from fall until early spring. See plant guides for more detailed information on each species. Plantings should be made from late winter to early spring.

Planting Depth

Plants for the dunes should be planted at least 6-8" or deep enough to have adequate soil moisture at the time of planting.

Use freshly dug bare root tillers, rooted stem cuttings or nursery grown potted vegetative material.

Use a tree dibble, or spade to plant the vegetative material.

Spacing

Plantings must consist of at least 10 feet (strips) of dune building vegetation. Wider areas may be considered based on the severity of the site. Herbaceous plant spacing ranges from 1-3 feet but is typically 18" for 1-4" potted stock or bare root plugs of the same diameter.

1st Year Fertilization

Initial fertilization is best done at planting with slow release complete fertilizer, such as 10-10-10, at a rate of 1 ounce per plant placed under the plant. Initial fertilization may also be provided with 200-300 pounds of mineral 10-10-10 per acre broadcast 6 weeks after planting.

2nd Year Fertilization

Maintenance fertilization should be provided with 400 pounds of 10-10-10 per acre per year split in two applications during the growing season before September 1. Fertilization is recommended until the plants spread to provide complete cover and after storms damage stands.

Irrigation

Supplemental water (irrigation) is usually needed on dune plantings to provide adequate moisture during the initial establishment period.



PLANTING GUIDE

'Atlantic' Coastal panicgrass (*Panicum amarum* var. *amarulum*)

Description: A tall, robust, warm-season, perennial grass. Growth habit is upright and the plant looks like a bunch grass, although it produces short rhizomes that may result in lateral spread of 4 to 8 inches annually. Plants are 3 to 7 feet in height with multi-stemmed bluish-green leaves $\frac{3}{4}$ to 1 inch wide by 12 to 20 inches long. Seed heads 4 to 8 feet in height are produced in late July through August or September and produce viable seed with strong seedling vigor.

- Native Habitat and Range: Coastal dunes throughout the North Atlantic and Gulf regions.
- Conservation Use: The principal use is in coastal dune erosion control. It is suitable for revegetating disturbed areas such as borrow and gravel pits and other areas with droughty and infertile conditions.
- Plant Materials: Seed and freshly dug root tillers (sprigs) are normally commercially available.
- Time of Planting: Plantings should be made from late winter until early spring and sprigs should be planted from November until March.
- Site Preparation and Seeding: Prepare a seedbed with tillage or drill seed and plant seed 2 inches deep. Surface seeding on sand dunes will likely not produce a successful stand. Use 10-15 pounds of seed per acre if planting and 20 pounds per acre if broadcasting.
- Planting Sprigs: Tillers (sprigs) should be planted in rows 6 to 8 feet apart and spaced about 18 inches apart in the rows. Tillers should be planted deep enough to be in moist soil (normally 4 to 10 inches) with the crown covered with $\frac{1}{2}$ to 1 inch of soil packed firmly around each tiller. This type of planting requires about 5,000 tillers per acre. Closer spacing of rows will significantly increase the time of coverage.
- Fertilizer: Fertilize at the time of planting with 200 to 300 pounds of 10-10-10 per acre or equivalent a few weeks after planting. Top dress with similar applications in late June and late summer until the stand is established.
- Protect from damage by foot and vehicular traffic and remove debris.

PLANTING GUIDE

'NORTHPA' and 'SOUTHPA' Bitter panicum (*Panicum amarum*)

Description: Perennial, warm season grass growing to a height of 7 feet with a growth habit ranging from erect to prostrate. The leaves are 1/4- to 1/2-inch wide, 7 to 20 inches long, smooth without hair, and bluish in color. This robust grass spreads slowly from short, strong rhizomes, forming open clumps. Small quantities of poor quality seed are produced on compact panicles 6 to 12 inches long and 2 to 4 inches wide.

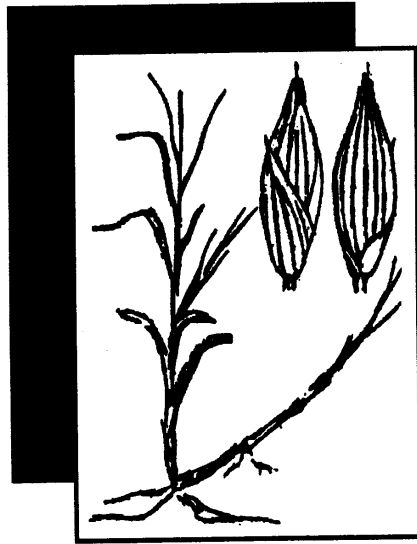

Bitter panicum

- **Native Habitat and Range:** Coastal dunes and sandy shores from New Jersey to Florida and Texas.

- **Conservation Use:** The principal use is in coastal dune erosion control and it may have a role in stabilizing other dry, sterile areas such as roadsides and minespoils.

- **Site Preparation:** Generally none required.

- **Plant Material:** Potted and bare root plants are available commercially. Freshly dug bare root tillers, rooted stem cuttings, and unrooted stem cuttings can also be obtained from vigorous stands.

- **Time of Planting:** Late fall with stem cuttings; late winter or early spring with potted plants; late spring with young tillers (when it coincides with the rainy season).

- **Spacing:** Plant potted and bare root material in a grid pattern 2 feet apart in 2 to 3 foot staggered rows. Plant stem cuttings three to a hole 2 feet apart in 2 to 3 foot staggered rows.

- **Depth:** Place plants 4 to 10 inches, or deeper, in moist soil. Plant stem cuttings at a 45-degree angle, deep enough to bury several nodes and leaving the top 6 to 10 inches of stem exposed.

- **Fertilizer:** Place one ounce of slow release fertilizer such as **Osmocote* in each hole as material is planted, or apply 200 to 300 pounds of 10-10-10 per acre 3 to 4 weeks after planting. Apply this same rate annually in June and repeat in August, until the stand fills in the spacing.

- **Maintenance:** Restrict traffic and livestock. Overgrazing and high palatability were responsible for the decrease of this plant in the 19th century.

PLANTING GUIDE

'FLAGEO' Marshhay cordgrass (*Spartina patens*)

Description: Perennial, warm season grass with erect stems, mostly less than 40 inches tall. It spreads by long slender rhizomes. Leaves are less than 1/8-inch wide and are sometimes flat, but usually roll inward from the edges with the upper surface inside. There are 2 to 7 spikes on the seedhead. These 3/4- to 2-inch spikes are born against or away from the stem.

- Native Habitat and Range: Salt marshes and sandy meadows from Quebec, Canada to Florida and Texas, and saline marshes inland from New York to Michigan.

- Conservation Use: Saltmeadow cordgrass is used for coastal erosion control in backdune areas, along tidal river banks, and on salt marshes above the high tide line. Inland uses include stabilizing waterways, gullies, roadsides, and minespoil and saline oil seep areas. The 'salt hay' is used as a mulch and fed to cattle.

- Site Preparation: None required, but removal of trash on tidal areas will prevent burial of plants.

- Plant Material: Potted plants or bare root stock are available commercially and from vigorous stands. Use transplants that have 5 to 10 stems each.

- Time of Planting: Late winter and early spring, and at the beginning of the rainy season in Florida.

- Spacing: Place plants 12 to 24 inches apart, depending on severity of site.

- Depth: Plant 4 to 8 inches, or deeper, in moist soil.

- Fertilizer: On critical area plantings, place one ounce of slow release fertilizer such as *Osmocote per plant at planting, or apply 200 to 300 pounds of 10-10-10 per acre several weeks after planting. Apply 200 to 300 pounds of 10-10-10 per acre annually in June until the stand fills in the spacing. Do not fertilize rangeland plantings.

- Maintenance: Minimize foot traffic and remove debris from planting.



Marshhay cordgrass

PLANTING GUIDE

Sea oats (*Uniola paniculata*)

Description: Perennial, erect, strong, rhizomatous, colonizing grasses native to the coastal sands and dunes of Florida and the southeastern United States. This grass forms in dense, rather stiff bunches 40 to 60 inches tall and 30 to 120 inches in diameter. Leaves are less than 1/2-inch in width, 16 to 28 inches long, and are usually flat. Leaves are rolled or involute on drying. Panicles of the seedhead are 8 to 12 inches long with numerous spikelets less than 1-inch long, each having 8 to 15 florets. Very little to no seed is produced by most seedheads and is readily eaten by birds. Only rarely is reproduction by natural germination of seed observed. Lateral spread and colony increase is accomplished by moderate to strong rhizome development.



Sea oats

- **Native Habitat and Range:** Sand dunes from southern Virginia to Florida and Texas.

- **Conservation Use:** Critical area stabilization of saline coastal sands and sand dunes.

- **Site Preparation:** Generally none required.

- **Plant Material:** Potted plants and bare root stock are available commercially and from vigorous stands. Use transplants with a minimum 30-inch stem height.

- **Time of Planting:** Late winter to early spring, and at the beginning of the rainy season in Florida.

- **Spacing:** Place plants 12 to 36 inches apart, depending on the pot size and severity of the site. Use 18-inch spacing for an average site using 2- to 4-inch pots.

- **Depth:** Place plants 8 to 12 inches, or deeper, in moist soil.

- **Fertilizer:** Place one ounce of slow release fertilizer such as *Osmocote in each hole as material is planted, or apply 200 to 300 pounds of 10-10-10 per acre 3 to 4 weeks after planting. To maintain and/or develop the stand, apply 200 to 300 pounds of 10-10-10 (or equivalent) per acre annually June 1 to June 15 and repeated August 1 to August 15.

- **Maintenance:** Minimize foot traffic and remove debris from planting.

This Page Intentionally Left Blank

Dune Walkover (DW)



Photo courtesy of Alabama Department of Environmental Management

Practice Description

A dune walkover is a measure consisting of elevated walks that are constructed across the dune system. It provides pedestrian access to the beach area and protects the dunes from erosion. It is applicable on sparsely vegetated dunes where pedestrian access adversely impacts the vegetation and on dunes with adequate vegetation where pedestrian access is planned and vegetation is needed to protect the dunes from erosion.

Planning Considerations

Coastal beaches are subject to regulations from a variety of Federal, State, and local agencies. Permits must be requested and granted by all appropriate jurisdictions before work is performed.

Coastal areas are affected by many dynamic systems. Detailed studies are often required to determine the possible effects that may result from dune modifications. Environmental assessments are generally required including public review and comment.

Dune walkovers are components of dune erosion control systems and are most effective when used with other practices including Dune Vegetation Planting and Dune Sand Fence.

Design Criteria

Scheduling

Attempt to construct dune walkovers during the recommended planting periods for the associated dune vegetation plantings that are planned.

Site Preparation

Ensure that all necessary materials are on the site before any work begins.

Construction

Develop construction plans based on sound building concepts that meet the requirements of the Coastal Nonpoint Pollution Control Program. Plans for Dune walkovers should consider the following guidance.

- Locate cross-over structures at sites that consider both people and site protection concerns.
- All load-bearing connections to the post should be made by bolts or lag screws.
- Utilize appropriate standard drawings developed specifically for the coastal zone if they are available.

Materials

All lumber materials should be pressure treated no. 2 yellow pine in accordance with American Wood Preservers Association Standard C-2. Treatment should be to 0.40 lbs. CCA per cubic foot, or greater or other copper-based preservatives with treatment rates recommended for ground contact applications.

All nuts, bolts, washers, nails, and other hardware should be hot dipped galvanized metal or other corrosion resistant fasteners.

Erosion Control

Plan to minimize the size of all disturbed areas and vegetate as soon as each phase of construction is complete.

Develop a planting plan that utilizes adapted species. See Figure DW-1 and Dune Vegetation Planting practice for details to incorporate into the planting plan.

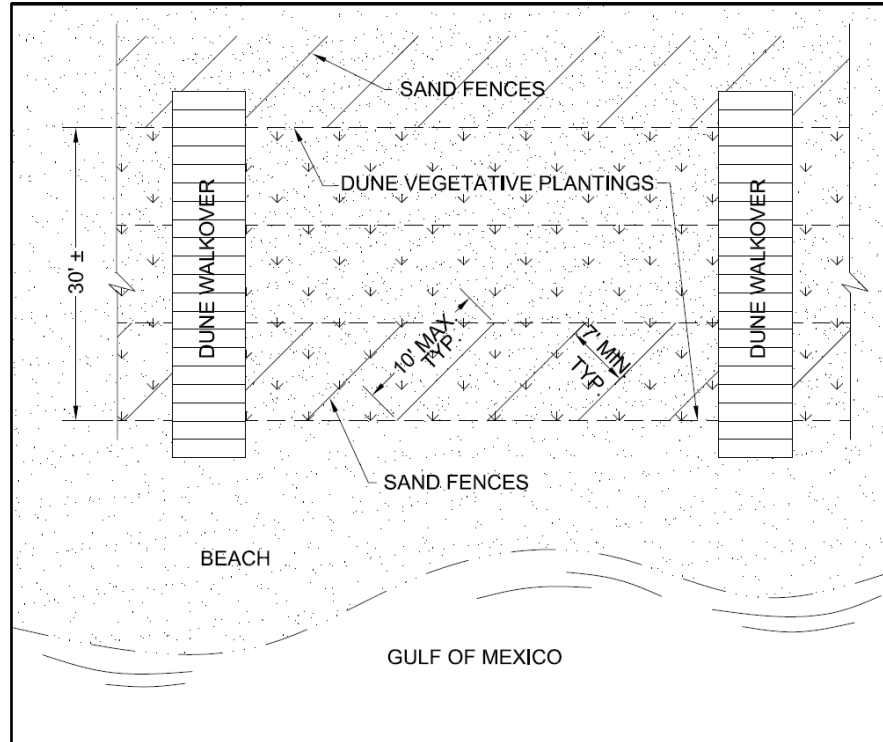

Figure DW-1 Typical Dune Walkover System

Safety

Specify that equipment used in construction should be free of leaks of fuel and hydraulic fluids.

Plan for fencing and warning signs if trespassing is likely during construction.

Construction Verification

Plan for construction inspections to determine that materials and construction meet plan specifications.

This Page Intentionally Left Blank

Dust Control (DC)



Practice Description

Dust control includes a wide range of techniques that prevent or reduce movement of wind-borne soil particles (dust) during land disturbing activities. This practice applies to construction routes and other disturbed areas where on-site and off-site damage or hazards may occur if dust is not controlled.

Planning Considerations

Construction activities that disturb soil can be a significant source of air pollution. Large quantities of dust can be generated, especially in “heavy” construction activities such as land grading for road construction and commercial, industrial or subdivision development.

The scheduling of construction operations so that the least amount of area is disturbed at one time is important in planning for dust control.

The greatest dust problems occur during dry periods. Therefore, to the extent practicable do not expose large areas of bare soil during drought conditions.

Where wind erosion is a potential cause of dust problems, preserving vegetation should be considered as a passive measure. Leave undisturbed buffer areas between graded areas wherever possible.

Installing temporary or permanent surface stabilization measures immediately after completing land grading will minimize dust problems.

Design Criteria

Permanent Methods

Vegetative Cover

Establish vegetative cover according to the Permanent Seeding or Temporary Seeding practice on areas not subject to traffic.

Topsoiling

This entails covering the surface with less erosive soil material. See Topsoiling practice for guidance.

Stone

Stone used to stabilize construction roads can also be effective for dust control. Stone should be spread a minimum of 6" thick over construction roads in the disturbed area. For heavily traveled roads or roads subjected to heavy loads the stone thickness should be 8" to 10". A non-woven geotextile meeting the minimum requirements of AASHTO M288 for a Class 2 separation geotextile should be used under the stone.

Temporary Methods

Mulches

Mulch offers a fast, effective means of controlling dust when properly applied. See Mulching practice for guidelines for planning and installing the practice.

Temporary Vegetative Cover

For disturbed areas where no activity is anticipated for 14 days or longer, temporary seeding can effectively control dust. Establish vegetative cover according to Temporary Seeding practice guidelines.

Calcium Chloride

Calcium chloride may be applied by mechanical spreader as loose, dry granules or flakes at a rate that keeps the surface moist but not so high as to cause water pollution or plant damage. Sites may need to be retreated because the product degrades over time.

Spray-on Adhesives

Spray-on adhesives may be used on mineral soils for dust control. Traffic must be kept off treated areas to prevent the product from becoming ineffective. Examples of spray-on adhesives for use in dust control are listed in Table DC-1.

Table DC-1 Spray-on Adhesives for Dust Control on Mineral Soil

Material	Water Dilution (adhesive:water)	Type of Nozzle	Apply Gal/Ac
Anionic Asphalt Emulsion	7:1	Coarse Spray	1,200
Latex Emulsion	12.5:1	Fine Spray	235
Resin in Water	4:1	Fine Spray	300

Chemical Stabilization (CHS)

Chemical products are available for use on mineral soils for dust control. Traffic must be often kept off treated areas to prevent the product from becoming ineffective. The manufacturer or supplier shall provide written application methods. The application method shall ensure uniform coverage to the target and avoid drift to non-target areas including waters of the State. The manufacturer or supplier shall also provide written instructions to ensure proper safety, storage, and mixing of the product. Refer to the Planning Considerations for the Chemical Stabilization practice for planning consideration before deciding to use these type products.

Sprinkling or Irrigation

Sprinkling is especially effective for dust control on haul roads and other traffic routes. Sprinkle the site until the surface is wet. Repeat as needed. Also, bare areas may be kept wet with irrigation to control dust as an emergency treatment.

Tillage

Tillage is used to roughen the site and bring clods and moist soil to the surface. This is a very temporary emergency measure that can be used on large open disturbed areas as soon as soil blowing starts. Begin tilling on the windward edge of the site. The depth of tillage is determined by the depth to moist soil and the amount of moist soil desired at the surface. In sandy soils, the depth to moist soil may make tillage impractical.

Barriers

A board fence, wind fence, sediment fence, hay bales, or similar barriers can control air currents and blowing soil. Place barriers perpendicular to prevailing air currents at intervals about 15 times the barrier height.

This Page Intentionally Left Blank

Erosion Control Blanket (ECB)



Photo courtesy of Sunshine Supplies, Inc.

Practice Description

Erosion Control Blanket is a practice using a rolled erosion control product (RECP) composed of processed natural or polymer fibers (straw, jute, wood paper or cotton, plastic, nylon) mechanically, structurally, or chemically bound together to form a continuous matrix used to provide erosion control and most often facilitates vegetation establishment. This practice is best utilized on slopes and channels where the erosion hazard is high, and plant growth is likely to be too slow to provide adequate protective cover. Erosion control blankets are typically used as an alternative to mulching but can also be used to provide structural erosion protection.

Planning Considerations

Care must be taken to choose the type of blanket that is most appropriate for the specific project needs. Some important factors in the choice of a blanket are soil conditions, steepness of slope, length of slope, type and duration of protection required to establish desired vegetation, and probable shear stress. Eighteen types of erosion control blankets are included in this practice and the type names and related information are from the materials developed by the Erosion Control Technology Council (ECTC). Manufacturer's instructions and recommendations, as well as a site visit by the qualified design professional and site plan reviewer are highly recommended to determine a product's appropriateness. When possible, consider the use of wildlife friendly netting.

Note: The Alabama Department of Transportation (ALDOT) identifies Rolled and Hydraulic Erosion Control Products based on performance. Description of ALDOT types can be found in Section 659 of their Standard Specifications for Highway Construction. ALDOT recognizes some Hydraulic Erosion Control Products equal in performance to Rolled Products.

Temporary Erosion Control Blankets

Benefits of using temporary erosion control blankets include the following:

- Protection of the seed and soil from raindrop impact and subsequent displacement.
- Thermal consistency and moisture retention for the seedbed area.
- Stronger and faster germination of grasses and legumes.
- Spreading stormwater runoff to prevent rill erosion of slopes.
- Prevention of sloughing of topsoil added to steeper slopes.

Because temporary blankets will deteriorate in a short period of time, they provide no enduring reduction in erosion potential.

Permanent Erosion Control Blankets

Permanent erosion control blankets are also known as permanent soil reinforcing mats or turf reinforcement mats (TRMs). Roots penetrate and become entangled in the matrix, forming a continuous anchorage for surface growth, and promoting enhanced energy dissipation.

Benefits of using permanent erosion control blankets, in addition to the benefits gained from using a temporary blanket include the following:

- Sediment from stormwater flows is deposited in the matrix providing a fine soil growth medium for the development of roots.
- In stormwater channels, blankets and the vegetative root system form an erosion resistant cover which resists hydraulic uplift and shear forces of channel flows.

Design Criteria

General

All blankets shall be nontoxic to vegetation and to the germination of seed and shall not be injurious to the unprotected skin of humans. Erosion control products shall be of sufficient strength to hold the prepared ground and, if applicable, cover material (mulch, sod, etc.) in place until an acceptable growth of natural or planted material is established. Erosion control products shall be identified by a type designation (Type 1.A, 2.B, 3.A, etc.) where the type is based on the functional

longevity and physical properties of the product. Type 1 products have a 3-month functional longevity, Type 2 a 12-month, Type 3 a 24-month, Type 4 a 36-month, and Type 5 are Turf Reinforcement Mats for long-term erosion protection.

Tables ECB-1 and ECB-2 give typical applications of the different types of erosion control blankets. ECTC’s recommended installation guide and standard specifications can be found on their website and at the following link:

<https://www.ectc.org/toolbox>

Table ECB-1 Temporary Erosion Control Blanket Types and Applications

Functional Longevity	Type	Application
3-Month	1.A	A Netting / Open Weave Textile for use on a maximum slope steepness of 5:1 and provides a shear stress of at least 1.0 lbs/ft ² .
3-Month	1.B	A Netless Rolled Erosion Control Blanket for use on a maximum slope steepness of 3:1 and provides a shear stress of at least 1.0 lbs/ft ² .
3-Month	1.C	A Single-Net Erosion Control Blanket for use on a maximum slope steepness of 3:1 and provides a shear stress of at least 1.5 lbs/ft ² .
3-Month	1.D	A Double-Net Erosion Control Blanket for use on a maximum slope steepness of 2:1 and provides a shear stress of at least 1.75 lbs/ft ² .
12-Month	2.A	A Netting / Open Weave Textile for use on a maximum slope steepness of 5:1 and provides a shear stress of at least 1.0 lbs/ft ² .
12-Month	2.B	A Netless Rolled Erosion Control Blanket for use on a maximum slope steepness of 3:1 and provides a shear stress of at least 1.0 lbs/ft ² .
12-Month	2.C	A Single-Net Erosion Control Blanket for use on a maximum slope steepness of 3:1 and provides a shear stress of at least 1.5 lbs/ft ² .
12-Month	2.D	A Double-Net Erosion Control Blanket for use on a maximum slope steepness of 2:1 and provides a shear stress of at least 1.75 lbs/ft ² .
24-Month	3.A	An Open Weave Textile for use on a maximum slope steepness of 2:1 and provides a shear stress of at least 2.0 lbs/ft ² .
24-Month	3.B	An Erosion Control Blanket for use on a maximum slope steepness of 1.5:1 and provides a shear stress of at least 2.0 lbs/ft ² .
36-Month	4.A	An Open Weave Textile for use on a maximum slope steepness of 1:1 and provides a shear stress of at least 2.25 lbs/ft ² .
36-Month	4.B	An Erosion Control Blanket for use on a maximum slope steepness of 1:1 and provides a shear stress of at least 2.25 lbs/ft ² .

Table ECB-2 Turf Reinforcement Mats (TRMs) Types and Applications

Type	Application
5.A	A TRM designed for use on geotechnically stable slopes up to 1:1, provide an unvegetated shear stress of at least 2.0 lbs/ft ² , and a vegetated shear stress of at least 6.0 lbs/ft ² .
5.B	A TRM designed for use on geotechnically stable slopes up to 1:1, provide an unvegetated shear stress of at least 2.0 lbs/ft ² , and a vegetated shear stress of at least 8.0 lbs/ft ² .
5.C	A TRM designed for use on geotechnically stable slopes up to 0.5:1, provide an unvegetated shear stress of at least 2.0 lbs/ft ² , and a vegetated shear stress of at least 10.0 lbs/ft ² .
5.D	A TRM designed for use on geotechnically stable slopes up to 0.5:1, provide an unvegetated shear stress of at least 2.0 lbs/ft ² , and a vegetated shear stress of at least 12.0 lbs/ft ² .
5.E	A TRM designed for use on geotechnically stable slopes up to 0.5:1, provide an unvegetated shear stress of at least 2.0 lbs/ft ² , and a vegetated shear stress of at least 12.0 lbs/ft ² .
5.F	A High Performance TRM designed for use on geotechnically stable slopes up to 1:1, provide an unvegetated shear stress of at least 2.0 lbs/ft ² , and a vegetated shear stress of at least 14.0 lbs/ft ² .

Type Designations and Materials

Erosion control products shall be composed of the materials shown in Tables ECB-3 and ECB-4.

Table ECB-3 Material Composition of Temporary Erosion Control Blankets

Type	Material Composition
1.A	A photodegradable synthetic mesh or woven biodegradable natural fiber netting.
1.B	Natural and/or polymer fibers mechanically interlocked and/or chemically adhered together to form an RECP.
1.C	Processed degradable natural and/or polymer fibers mechanically bound together by a single rapidly degrading, synthetic or natural fiber netting.
1.D	Processed degradable natural and/or polymer fibers mechanically bound together between two rapidly degrading, synthetic or natural fiber nettings.
2.A	A photodegradable synthetic mesh or woven biodegradable natural fiber netting.
2.B	Natural and/or polymer fibers mechanically interlocked and/or chemically adhered together to form an RECP.
2.C	Processed degradable natural and/or polymer fibers mechanically bound together by a single degrading, synthetic or natural fiber netting.
2.D	Processed degradable natural and/or polymer fibers mechanically bound together between two degradable, synthetic, or natural fiber nettings.
3.A	An open weave textile composed of processed slow degrading natural or polymer yarns or twines woven into a continuous matrix.
3.B	An erosion control blanket composed of processed slow degrading natural or polymer fibers mechanically bound together between two slow degrading synthetic or natural fiber nettings to form a continuous matrix.
4.A	An open weave textile composed of processed slow degrading natural or polymer yarns or twines woven into a continuous matrix.
4.B	An erosion control blanket composed of processed slow degrading natural or polymer fibers mechanically bound together between two slow degrading synthetic or natural fiber nettings to form a continuous matrix.

Table ECB-4 Material Composition of Turf Reinforcement Mats

Type	Material Composition
5.A 5.B 5.C 5.D 5.E	A product composed of UV-stabilized non-degradable synthetic fibers, filaments, nets, wire mesh and/or other elements, processed into a permanent, three-dimensional matrix which may be supplemented with degradable components.
5.F	A product composed of UV-stabilized, non-degradable, synthetic fibers, filaments, nets, wire mesh and/or other elements, processed into a permanent, three-dimensional matrix for highest performance.

Materials Physical Requirements

A properly designed erosion control blanket installation requires selection of a product manufactured with physical properties to withstand the stresses the product will be subjected to for the design life of the product. Refer to the ECTC standard specifications for the minimum physical requirements for each type of blanket.

Product Placement

General. Refer to the ECTC Installation Guide for the general guidelines for the installation of rolled erosion control products (RECPs); however, the ECTC guidelines do not supersede the manufacturer's installation guidelines.

Prior to installation of a RECP, the surface on which it is to be placed must be properly prepared. The surface should be stable and firm, the top soil should be evenly spread if specified, and the soil amendments added. The soil pH in the root zone and soil compaction **MUST** be addressed for long-term vegetal success. Fertilizer and lime applications per soil test recommendations should always be incorporated into the soil surface whenever possible. Some RECPs may require an application of mulch prior to placement of the blanket. Some TRMs may require soil or hydraulically-applied matrix in-filling after placement of the blanket. For soil in-filling, some of the soil amendment and the seed should be applied to the soil in-fill and lightly brushed or raked in to cover the seed.

Blankets shall be rolled out in the direction of flow to reduce rill erosion. The RECP should always have intimate contact with the soil surface over the entire installation. Do not stretch the RECP over surface irregularities.

For temporary blankets, staples should be U-shaped wire with an 11-gauge thickness or greater. Staples should be of sufficient thickness for soil penetration without undue distortion. The legs of the staples shall be at least 6" long with a crown of 1". Appropriate biodegradable staples can be used in lieu of wire staples.

Permanent blankets shall be anchored in one of two ways. Blankets can be anchored using sound wood stakes, 1" by 3" stock sawn in a triangular shape. The length of the stakes shall be from 12" to 18" depending upon the soil compaction at the site. Stakes shall be installed on 4 feet centers along each edge of the blanket. Blankets can also be anchored using U shaped staples of 11-gauge steel or greater with a minimum leg length of 8" and a 2" crown.

Upslope Anchor. The upslope portion of the RECP should be properly anchored. There are several different techniques that can be used. Always refer to the manufacturer's or the ECTC installation guidelines for the proper technique.

Seams. Edges of the RECP should be properly secured to adjacent blankets. There are several different techniques used to prevent seam or abutted rolls from separating. Always refer to the manufacturer's or the ECTC installation guidelines for the proper technique.

Terminal Ends. RECP should be securely fastened at the terminal end of the blanket. Always refer to the manufacturer's or the ECTC installation guidelines for the proper technique.

Slopes. RECP should be securely fastened to the soil by installing stakes/staples at a minimum rate of 1.3/yd² within the body of the blanket. Always refer to the manufacturer's or the ECTC installation guidelines for the proper technique.

Channels. Always follow manufacturer's or ECTC guidelines for anchor trenches or stake/staple check slots, seaming, and terminal end anchoring. Unroll RECPs down the center of the channel in the primary water flow direction. Securely fasten all RECPs to the soil by installing stakes/staples at a minimum rate of 1.7/yd². Significantly higher anchor rates and longer stakes/staples may be necessary in sandy, loose, or wet soil and in severe applications. Always refer to the manufacturer's or the ECTC installation guidelines for the proper technique for staking/stapling.



Figure ECB-1 RECP Slope Installation.
Photo courtesy of John Slupecki.



Figure ECB-2 Topsoil "In-Fill" Being Placed in TRM.



Figure ECB-3 TRM in the Middle of a Swale.



Figure ECB-4 TRM with Pre-Marked Stapling Pattern.

Groundskeeping (GK)



Practice Description

Groundskeeping, or “good housekeeping”, describes the various activities and measures, in addition to the specific practices used for erosion and sediment control that are essential during construction for the protection of environmental quality. Groundskeeping is applicable at all construction sites.

Planning Considerations

In addition to the sediment and erosion control practices included in the Handbook that deal directly with sediment and erosion control, some general groundskeeping measures are essential to the pollution prevention aspect of a Stormwater Pollution Prevention Plan. Included in the Groundskeeping practice are the following different areas:

- Inspection and Maintenance Procedures
- Materials Inventory
- Spill Prevention and Material Management Measures
- Spill Controls
- Hazardous Products
- Air Emissions (excessive odor)
- Other Good Groundskeeping Measures (i.e. fugitive spray, excessive noise and aesthetics)

Design Criteria

Inspection and Maintenance Procedures

The following inspection and maintenance procedures need to be followed to maintain adequate sediment and erosion controls:

- All control measures need to be inspected at least once per week and following any accumulation of rainfall of $\frac{3}{4}$ " or more within a 24-hour period. A more frequent inspection interval may be required by either a permitting agency or a permittee.
- All measures need to be maintained in good working order. If a repair is necessary, it should be initiated within 24 hours of report.
- Sediment Barriers need to be inspected weekly for proper anchorage and leakage underneath. Silt fencing should also be inspected for tears.
- Built-up sediment needs to be removed from sediment barriers when it has reached $\frac{1}{2}$ of the height of the barrier. Sediment needs to be placed in a stabilized site to prevent re-entry into the same site or another entrapment area.
- Sediment basins need to be inspected monthly for depth of sediment and built-up sediment needs to be removed when $\frac{1}{2}$ of the basin volume is filled.
- Temporary and permanent seeding and plantings need to be inspected for bare spots, washouts, and unhealthy growth. A person should be designated to be responsible for maintaining planted areas until there is a uniform stand with 85% ground cover and growth has reached 1" in height.

Materials Inventory

A materials list should be compiled for items that will be stored outside on the site during construction. For example:

- _____ Pipe, fittings, and joint compounds for underground utility piping
- _____ Gravel and stone bedding material
- _____ Concrete forming materials
- _____ Other (specify) _____
- _____
- _____
- _____

Note: Fuels, oils, and other petroleum products; forming oils and compounds; fertilizers; pesticides; strippers; detergents; cleaners; or any other hazardous or toxic compounds should not be stored outside on the site unless specifically agreed upon by all responsible parties, including those persons responsible for enforcing local ordinances and policies. On-site storage should meet all local, state, and federal rules regarding secondary containment. Additionally, local ordinances may require fencing and security measures for storage of these products.

Spill Prevention and Material Management Practices

Petroleum Products

All vehicles kept on the site need to be monitored for leaks and receive regular preventive maintenance to reduce the chance of leakage. A Spill Prevention Control and Countermeasures (SPCC) plan should be developed for the facility to address the safe storage, handling and clean-up of petroleum products and other chemicals. Petroleum products should be stored in tightly sealed containers, which are clearly labeled. If petroleum products are stored on site, a secondary containment facility will be required if the cumulative storage capacity of all tanks, greater than 55 gallons, at the site exceeds 1,320 gallons. Any asphalt substances used on-site should be applied according to the manufacturer's recommendations.

Fueling & Servicing

Locate these types of activities as far away as possible from waters of the State and stormwater inlets or conveyances so that stormwater coming into contact with these activities cannot reach water of the State. No fueling, servicing, maintenance, or repair of equipment or machinery should be done within 50 feet of a stream, or within 100 feet of a stream classified for public water supply (PWS) or Outstanding Alabama Water (OAW) or designated as an Outstanding National Resource Water (ONRW), or a sinkhole.

Mud Tracking

A stabilized construction entrance needs to be designated on the plan. The practice Construction Exit Pad provides design details for planning such an entrance. Only designated entrances should be used for construction access to the site.

The General Contractor should be responsible for keeping mud cleaned from adjoining streets daily if needed. Only use “dry” methods like sweeping to remove mud from streets. DO NOT use water to flush mud from the street.

Concrete Trucks

Concrete trucks should be allowed to wash only in locations where discharge is appropriately contained and meets any applicable regulatory requirements. All the concrete truck washout or waste discharge on-site must be contained to be properly removed, recycled, or disposed of later. Containment can be in the form

of metal, vinyl, plastic, or poly lined containers or pits, filter bags, or manufactured products. It is best to use proper signage at the concrete washout location. It is not permissible to discharge concrete wash directly to streams or storm drains. Concrete wash can contain sediment, as well as, alkalinity and chemical additives that could be harmful to fish, stream bottom macroinvertebrates and wildlife.

Disposal of Oil

No fuels, oils, lubricants, solvents, or other hazardous materials can be disposed of on the site. All hazardous material must be properly disposed of in accordance with State law.

Trash/Solid Waste

Waste containers should be located as far away as possible from waters of the State and stormwater inlets or conveyances so that stormwater coming into contact with these activities cannot reach water of the State. The General Contractor is responsible for disposing of all solid waste from the site in accordance with State law. Dumpsters or other collection facilities must be provided as needed. Solid waste may not be buried on the site.

Sanitary Waste

The General Contractor is responsible for providing sanitary facilities on the site. Sanitary waste may be disposed only in locations having a state permit. Portable toilets should be located so that accidental spills will not discharge into a storm sewer or concentrated flow area.

Other Discharges

Water for pressure testing sanitary sewers, flushing water lines, sand blasting, concrete cleansing, etc., may be discharged only in approved areas. Discharge of hydrostatic test water may require additional permitting, particularly if chlorinated public water is used.

Spill Controls

In addition to the good housekeeping measures and material management measures listed previously, the following procedures need to be followed for spill prevention and clean-up:

- Manufacturer's recommended methods for spill cleanup needs to be clearly posted and site personnel need to be made aware of the procedures and the location of the information and cleanup supplies. Refer to material safety data sheets (Material Safety Data Sheet).
- Material and equipment necessary for spill cleanup needs to be kept in the material storage area on-site. Equipment and materials include, but are not limited to: brooms, dust pans, mops, rags, gloves, goggles,

absorbent clay (kitty litter), sand, sawdust, absorbent mats, and plastic and metal trash containers specifically for this purpose.

- All spills need to be cleaned up immediately after discovery and properly containerized for proper disposal. Burial is not acceptable.
- The spill area must be kept well ventilated, and personnel need to wear appropriate protective clothing to prevent injury from contact with a hazardous substance.
- Spills of toxic or hazardous material must be reported immediately to the appropriate state or local government agency, regardless of the size.
- The spill prevention plan needs to be adjusted to include measures to prevent this type of spill from being repeated, and the plan needs to show how to clean up the spill if another one does occur.

Contaminated Soils

Removal of contaminated soils and underground storage tanks should be based on information provided by the Alabama Department of Environmental Management following a proper site assessment.

Hazardous Products

- Products must be kept in original containers unless they are not resealable. If product is transferred to a new container, it must be properly marked and labeled.
- Original labels and material safety data sheets should be retained.
- If surplus product must be disposed, disposal must be done in accordance with Alabama Department of Environmental Management regulations.

Air Emissions

Burning

Burning on the site may require a permit from the Alabama Forestry Commission. County or city ordinances may also apply. Starting disposal fires with diesel fuel or old tires is not a recommended practice. The use of burn pits with fans to generate hot disposal fires decreases the fire disposal time and minimizes smoke.

Dust Control

Apply measures that minimize dust. Stabilizing areas with mulch as soon as possible can minimize dust. Watering should be provided in unstabilized areas.

Other Good Groundskeeping Measures

The following good housekeeping measures also need to be followed during the construction of the project:

- An effort should be made to store only enough products to do the job.
- All materials stored on-site should be stored in a neat, orderly manner in their appropriate containers and, if possible, under a roof or other enclosure.
- Products should be kept in their original containers with the original manufacturer's label.
- Whenever possible, all of a product should be used up before disposing of the container.
- Manufacturer's recommendations for proper use and disposal must be followed (see Material Safety Data Sheet).
- The site superintendent should inspect daily to ensure proper usage, storage, and disposal of materials.
- Fertilizers need to be applied only in the amounts recommended by the plan.
- All paint containers need to be tightly sealed and stored when not required for use. Excess paint and painting equipment cleaning liquid shall not be dumped into the storm sewer system but should be properly disposed of according to manufacturer's instructions (see Material Safety Data Sheet) and State regulations.
- The site should be kept clean and well groomed (trash picked up regularly, weeds mowed, and signs maintained).
- Offsite fugitive spray from dust control, sand blasting and pressure washing must be minimized to the extent possible.
- Locate activities that generate odors and noise as far from surrounding properties as possible (this item includes portable toilets burn sites, fueling areas, equipment repair areas and dumpsters).

Mulching (MU)



Practice Description

Mulching is the application of plant residues such as straw or other suitable materials to the soil surface to minimize erosion. Mulching is used to support permanent and temporary seeding and, also, to provide short-term cover without seeding.

Planning Considerations

Surface mulch is the most effective, practical means of controlling runoff and erosion on disturbed land prior to vegetation establishment. Mulch absorbs the energy associated with raindrops and thereby minimizes soil particle detachment, which is the initial step of erosion.

Mulch also reduces soil moisture loss by evaporation, prevents crusting and sealing of the soil surface, moderates soil temperatures, and provides a suitable microclimate for seed germination.

Organic mulches such as straw, wood chips and shredded bark have been found to be very effective mulch materials. Materials containing weed and grass seeds which may compete with establishing vegetation should not be used. Also, decomposition of some wood products can tie up significant amounts of soil nitrogen, making it necessary to modify fertilization rates or add fertilizer with the mulch.

Hydraulic Erosion Control Products (HECPs) as defined by the Erosion Control Technology Council (ECTC) can also be used as effective mulch applications. HECPs are designated as 5 different types based on product characteristics and performance. Information from the ECTC table dated April 2014 is provided as Table MU-1. To ensure that you use the most valid information refer to the latest HECP specifications provided by the ECTC or the manufacturer's recommendation. The Alabama Department of Transportation characterizes mulches based on performance levels identified in Sections 656 and 659 of their Standard Specifications for Highway Construction.

The choice of materials for mulching should be based on soil conditions, season, type of vegetation to establish, and size of the area. Properly applied and tacked mulch is always beneficial. Mulching is especially important when conditions of germination are not optimum, such as midsummer and early winter, and on difficult sites such as cut slopes, fill slopes and droughty soils.

Straw has traditionally been the most commonly used mulching material in conjunction with seeding. Wheat straw is the mostly commonly used straw and can be spread by hand or with a mulch blower. If the site is susceptible to blowing wind, the straw should be tacked down with a tackifier, or a crimper to prevent loss.

Wood chips are suitable for areas that will not be closely mowed, and around ornamental plantings. Chips do not require tacking. Because they decompose slowly, they must be treated with 12 pounds of nitrogen per ton to prevent nutrient deficiency in plants. This can be an inexpensive mulch if the chips are obtained from trees cleared on the site.

Compost, peanut hulls, and pine straw are organic materials that potentially make excellent mulches but may only be available locally or seasonally. Creative use of these materials may reduce costs.

Jute mesh or the various types of netting is very effective in holding mulch in place on waterways and slopes before grasses become established. Always consider the use of wildlife friendly netting products.

Erosion control blankets promote seedling growth in the same way as organic mulches and are suited for use in areas with concentrated flows (see Erosion Control Blanket practice).

Table MU-1 Hydraulic Erosion Control Products (HECP) Specification Chart ¹

Hydraulic Erosion Control							
Type HECP ²	Term	Functional Longevity ³	Typical Application Rates Lbs/acre (kg/ha)	Typical Maximum Slope Gradient (H:V)	Maximum Uninterrupted Slope Length (ft)	Maximum C Factor ^{4, 5} (3:1 test)	Minimum Vegetation Establishment ⁶
1	Ultra Short Term	1 month	1500—2500 (1700—2800)	≤ 5:1	20	0.3	150 %
2	Short Term	2 month	2000—3000 (2250—3400)	≤ 4:1	25	0.2	150 %
3	Moderate Term	3 month	2000—3500 (2250—3900)	≤ 3:1	50	0.1	200 %
4	Extended Term	6 month	2500—4000 (2800—4500)	≤ 2:1	75	0.05	300 %
5	Long Term	12 month	3000—4500 (3400—5100)	≤ 2:1	100	0.02	300 %

¹ This table is for general guidelines only. Refer to manufacturer for application rates, instructions, gradients, maximum continuous slope lengths and other site-specific recommendations.

² These categories are independent of rolled erosion control products (RECPs) categories, despite the identical names.

³ A manufacturer's estimated time period, based upon field observations, that a material can be anticipated to provide erosion control as influenced by its composition and site-specific conditions.

⁴ "C" Factor calculated as ratio of soil loss from HECP protected slope (tested at specified or greater gradient, h:v) to ratio of soil loss from unprotected (control) plot based on large-scale testing.

⁵ Acceptable large-scale test methods may include ASTM D 6459, or other independent testing deemed acceptable by the engineer.

⁶ Minimum vegetation establishment is calculated as outlined in ASTM D 7322 being a percentage by dividing the plant mass per area of the protected plot by the plant mass per area of the control plot.

EROSION CONTROL TECHNOLOGY COUNCIL —WWW.ECTC.ORG

ECTC makes no representations or warranties of any kind express or implied, about the completeness, accuracy, reliability, suitability or availability with respect to the website or the information, products, services, or related graphics contained on the website for any purpose. Any reliance you place on such information is therefore strictly at your own risk.

(Source: Erosion Control Technology Council, April 2, 2014)

Design Criteria

Site Preparation

Before mulching, complete the required site preparation. Site preparation includes grading, if needed, and seedbed preparation and fertilizing, liming and seeding if a planting is being made by means other than hydroseeding.

Spreading the Mulch

Select a mulch material based on the site and practice requirements, availability of material, and availability of labor and equipment. Table MU-2 lists commonly used mulches.

Table MU-2 Mulching Materials and Application Rates

Material	Rate Per Acre and (Per 1000 ft. ²)	Notes
Straw with Seed	1 ½-2 tons (70 lbs-90 lbs)	Spread by hand or machine to attain 75% groundcover; anchor when subject to blowing.
Straw Alone (no seed)	2 ½-3 tons (115 lbs-160 lbs)	Spread by hand or machine; anchor when subject to blowing.
Wood Chips	5-6 tons (225 lbs-270 lbs)	Treat with 12 lbs. nitrogen/ton.
Bark	35 cubic yards (0.8 cubic yard)	Can apply with mulch blower.
Pine Straw	1-2 tons (45 lbs-90 lbs)	Spread by hand or machine; will not blow like straw.
Peanut Hulls	10-20 tons (450 lbs-900 lbs)	Will wash off slopes. Treat with 12 lbs. nitrogen/ton.
HECPs	0.75 – 2.25 tons (35 lbs – 103 lbs)	Refer to ECTC or Manufacturer's Specifications.

Uniformly spread organic mulches by hand or with a mulch blower at a rate which provides about 75% ground cover. Spread HECPs utilizing appropriate equipment and at rates as specified. When spreading straw mulch by hand, divide the area to be mulched into sections of approximately 1000 sq. ft. and place 70-90 pounds of straw (1 ½ to 2 bales) in each section to facilitate uniform distribution. **Caution:** *An over-application of wheat straw will reduce stand success – do not over-apply wheat straw when mulching a seeding!*

When straw mulch is subject to be blown away by wind, it must be anchored immediately after spreading. It is best anchored with a mulch anchoring tool.

Application of a commercial tackifier through a hydroseeder is often practical for steep slopes and can be effective on most sites. Binders (tackifiers) may be applied after mulch is spread or may be sprayed into the mulch as it is being blown onto the soil. Applying straw and binder together is the most effective

method. Liquid binders include an array of commercially available synthetic binders and organic tackifiers.

In high wind situations like roadways, crimping the mulch is the best alternative as the use of mulch binders may still result in the mulch being rolled up on the edge.

Straw mulch may also be anchored with lightweight plastic, cotton, jute, wire or paper netting which is stapled over the mulch. The manufacturer's recommendations on stapling netting should be followed. Consider the use of wildlife friendly netting.

Maintenance

Inspect all mulches periodically, and after rainstorms to check for rill erosion, dislocation, or failure. Where erosion is observed, apply additional mulch or if washout has occurred, repair the slope grade, reseed, and reinstall mulch. Continue inspections until vegetation is firmly established.

This Page Intentionally Left Blank

Permanent Seeding (PS)



Practice Description

Permanent seeding is the establishment of perennial vegetation from seed. This practice is used when vegetation is desired and appropriate to permanently stabilize the soil.

Planning Considerations

The advantages of seeding over other means of establishing plants include the smaller initial cost, lower labor input, and greater flexibility of method.

Disadvantages of seeding include potential for erosion during the establishment stage, seasonal limitations on suitable seeding dates, and weather-related problems such as droughts.

The probability of successful plant establishment can be maximized through good planning. The selection of plants for permanent vegetation should be site specific and based on plant characteristics, wear and mowing tolerance, soil conditions, time of year of planting, method of planting, the intended use, and management requirement of the vegetated area. Climate factors can vary widely in Alabama. Important plant attributes are discussed in Vegetation Establishment for Erosion and Sediment Control in Chapter 2. Other factors that may be important are wear, mowing tolerance, and salt tolerance of vegetation.

Plant selection may include companion plants to provide quick cover on difficult sites, late seedings, or where the desired permanent cover may be slow to

establish. Annuals are usually used for companion plants and should be selected carefully to prevent using a species that provide so much competition that it prevents the establishment of the desired species.

Seeding properly carried out within the optimum planting dates has a higher probability of success. It is also possible to have satisfactory establishment when seeding outside these dates. However, as plantings are deviated from the optimum dates, the probability of failure increases rapidly. Seeding dates should be taken into account in scheduling land-disturbing activities.

Site quality impacts both short-term and long-term plant success. Sites that have compacted soils, soils that are shallow to rock or have textures that are too clayey or too sandy should be modified whenever practical to improve the potential for plant growth and long-term cover success.

The operation of equipment is restricted on slopes steeper than 3:1, severely limiting the quality of the seedbed that can be prepared. Provisions for establishment of vegetation on steep slopes can be made during final grading. In construction of fill slopes, for example, the last 4-6" might not be compacted. A loose, rough seedbed with irregularities that hold seeds and lime and fertilizer is essential for hydroseeding. Cut slopes should be roughened (see Land Grading practice).

Appropriate mulching is critical to protect against erosion on steep slopes. When using straw, anchor with netting or asphalt. On slopes steeper than 3:1, rolled erosion control products or hydraulic erosion control products are usually needed.

The use of irrigation (temporary or permanent) will greatly improve the success of vegetation establishment.

Design Criteria

Plant Selection

Select plants that can be expected to meet planting objectives. To simplify plant selection, use Figure PS-1 Geographical Areas for Species Adaptation and Seeding Dates and Table PS-1, Commonly Used Plants for Permanent Cover. Mixtures commonly specified by the Alabama Department of Transportation are an appropriate alternative for plantings on rights-of-ways. Additional information related to plants commonly used in Alabama is found in Chapter 2 under the section Vegetation for Erosion and Sediment Control.

The plants used for temporary vegetation may be used for companion plants provided the seeding rate of the annual species is reduced by one half. See the Temporary Seeding practice for additional information on establishing temporary vegetation. **Ryegrass or other highly competitive plants should not be used as a companion plant with a permanent seeding.**

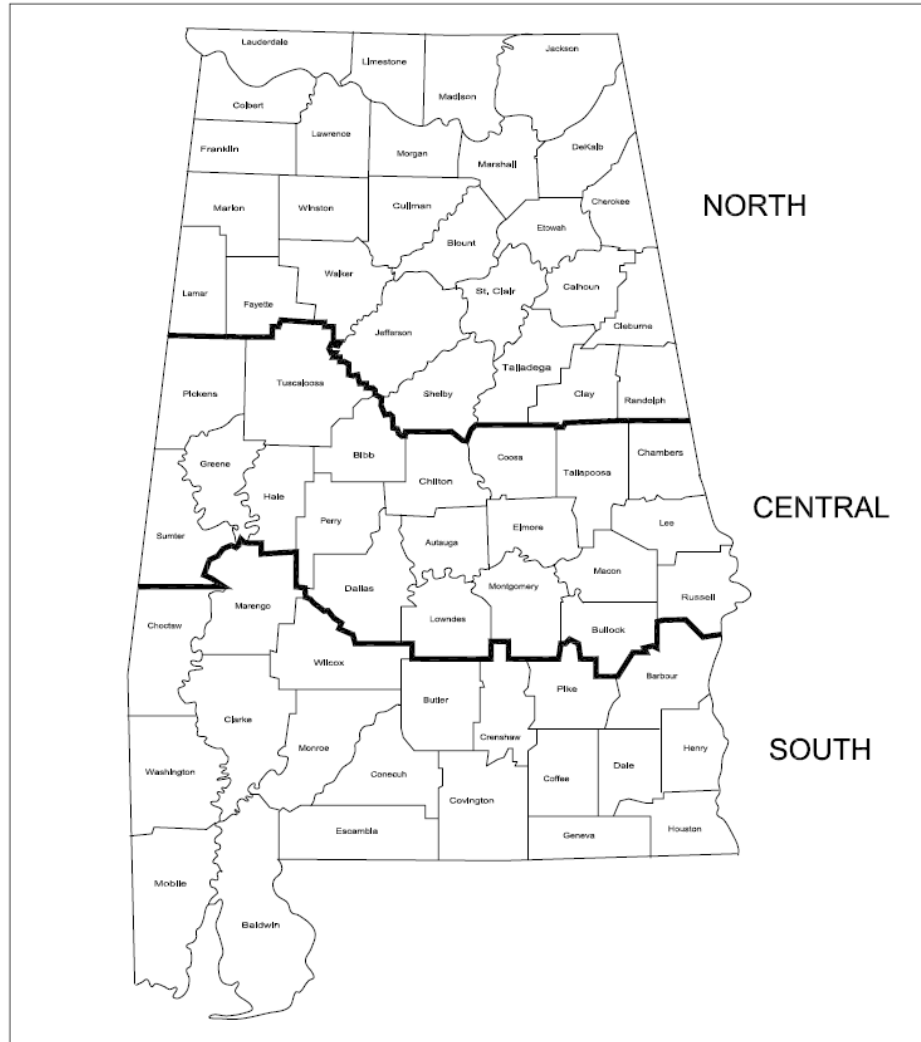

Figure PS-1 Geographical Areas for Species Adaptation and Seeding Dates

Note: Site conditions related to soils and aspect in counties adjacent to or close to county boundaries may justify adjustments in planting dates by qualified design professionals.

Table PS-1 Commonly Used Plants for Permanent Cover with Seeding Rates and Dates¹

Species	Seeding Rates/Ac PLS ²	North	Central	South
		Seeding Dates		
Bahiagrass, Pensacola	40 lbs	--	Mar 1-July 1	Feb 1-Nov 1
Bermudagrass, Common	10 lbs	Apr 1-July 1	Mar 15-July 15	Mar 1-July 15
Bahiagrass, Pensacola Bermudagrass, Common	30 lbs 5 lbs	--	Mar 1-July 1	Mar 1-July 15
Bermudagrass, Hybrid (Lawn Types)	Solid Sod	Anytime	Anytime	Anytime
Bermudagrass, Hybrid (Lawn Types)	Sprigs 1/sq ft	Mar 1-Aug 1	Mar 1-Aug 1	Feb 15-Sep 1
Fescue, Tall	40-50 lbs	Sep 1-Nov 1	Sep 1-Nov 1	--
Sericea	40-60 lbs	Mar 15-July 15	Mar 1-July 15	Feb 15-July 15
Sericea & Common Bermudagrass	40lbs 10 lbs	Mar 15-July 15	Mar 1-July 15	Feb 15-July 15
Switchgrass, Alamo	4 lbs	Apr 1-Jun 15	Mar 15-Jun 15	Mar 15-Jun 15

- 1 DO NOT USE Seeding Rates as part of a mixture unless shown as a mixture in this table.
 2 PLS means Pure Live Seed and is used to adjust seeding rates. For example, to plant 10 lbs PLS of a species with germination of 80% and purity of 90%, PLS= 0.8 X 0.9 = 72%. 10lbs PLS = 10/0.72 = 13.9 lbs of the species to be planted.

Seedbed Requirements

Establishment of vegetation should not be attempted on sites that are unsuitable due to compaction or inappropriate soil texture, poor drainage, concentrated overland flow, or steepness of slope until measures have been completed to correct these problems. To maintain a good stand of vegetation, the soil must meet certain minimum requirements as a growth medium. A good growth medium should have these attributes:

- Sufficient pore space to permit root penetration.
- Enough fine-grained soil material (silt and clay) to maintain adequate moisture and nutrient supply.
- Sufficient depth of soil to provide an adequate root zone. The depth to rock or impermeable layers such as hardpans should be 12" or more, except on slopes steeper than 2:1 where topsoiling is not feasible.
- A favorable pH range for plant growth, usually 6.0-6.5.

- Sufficient nutrients (nitrogen, phosphorus, and potassium) for initial plant establishment.
- Freedom from large roots, branches, stones, or large clods. Clods and stones may be left on slopes steeper than 3:1 if they are to be hydroseeded.

If any of the above attributes are not met i.e., if the existing soil is too dense, coarse, shallow or acidic to foster vegetation – chiseling, topsoil, or special amendments should be used to improve soil conditions. The soil conditioners described below may be beneficial or topsoil may be applied (for guidance on topsoiling see Topsoiling practice). These amendments should only be necessary where soils have limitations that make them poor for plant growth or for turf establishment.

- Peat-appropriate types are sphagnum moss peat, reed-sedge peat, or peat humus, all from fresh-water sources. Peat should be shredded and conditioned in storage piles for at least 6 months after excavation.
- Sand-should be clean and free of toxic materials.
- Vermiculite-use horticultural grade.
- Rotted manure-use stable or cattle manure not containing undue amounts of straw or other bedding materials.
- Thoroughly rotted sawdust-should be free of stones and debris. Add 6 lbs of nitrogen to each cubic yard.
- Manufactured products that improve stand establishment and performance of the turf.

Soil Amendments

Liming Materials

Lime (Agricultural limestone) should have a neutralizing value of not less than 90 percent calcium carbonate equivalent and 90 percent will pass through a 10-mesh sieve and 50 percent will pass through a 60-mesh sieve.

Selma chalk should have a neutralizing value of not less than 80 percent calcium carbonate equivalent and 90 percent will pass through a 10-mesh sieve.

Other liming materials that may be selected should be provided in amounts that provide equal value to the criteria listed for agricultural lime or be used in combination with agricultural limestone or Selma chalk to provide equivalent values to agricultural limestone.

Plant Nutrients

Commercial grade fertilizers that comply with current Alabama Fertilizer Laws should be used to supply nutrients required to establish vegetation.

Lime and fertilizer needs should be determined by soil tests. Soil testing is performed by the Auburn University Soil Testing Laboratory and provides recommendations based on field tests on Alabama soils. The local county Cooperative Extension Service can provide information on obtaining soil tests. Commercial laboratories that make recommendations based on soil analysis may be used.

When soil tests are not available, use the following rates for application of soil amendments:

Lime Rates

Sandy soils: Use 1 ton/acre (exception on sandy soils – if the cover will be tall fescue and clover) use 2 tons/acre.

Clayey soils: 2 tons/acre.
(Do not apply lime to alkaline soils).

Fertilizer Rates

Grasses alone: Use 400 lbs/acre of 8-24-24 or the equivalent. Apply 30 lbs of additional nitrogen when grass has emerged and begun growth (approximately 0.8lbs/1000 ft²).

Grass-legume mixtures: Use 800 to 1200 lbs/acre of 5-10-10 or the equivalent.
Legumes Alone: Use 400 to 600 lbs/acre of 0-20-20 or the equivalent.

Note: Fertilizer can be blended to meet exact fertilizer recommendations. Take soil test recommendations to local fertilizer dealer for bulk fertilizer blends. This may be more economical than bagged fertilizer.

Application of Soil Amendments

Apply lime and fertilizer evenly and incorporate into the top 6" of soil by disking, chiseling, or other suitable means during seedbed preparation. Operate machinery on the contour. On sites too steep for seedbed preparation, fertilizer and lime can be applied with a hydroseeder.

Seedbed Preparation

If needed, grade and shape to provide a surface on which equipment can safely and efficiently be used for seedbed preparation and seeding.

Install necessary sediment control practices before seedbed preparation and complete grading according to the approved plan.

Prepare a friable seedbed with tillage to a depth of at least 6". Break up large clods, alleviate compaction, and smooth and firm the soil into a uniform surface. Fill in or level depressions that can collect water.

Planting Methods

Seeding

Use certified seed for permanent seeding whenever possible. Certified seed is inspected by the Alabama Crop Improvement Association to meet high quality standards and will be tagged with a "Certified Seed" tag. (Note: all seed sold in Alabama is required by law to be tagged to identify seed purity, germination, and presence of weed seeds. Seed must meet state standards for content of noxious weeds.)

Seeding dates are determined using Figure PS-1 and Table PS-1.

Inoculate legume seed with the Rhizobium bacteria appropriate to the species of legume if seed are not coated with the appropriate inoculant. Details of legume inoculation are located in Chapter 2 in the part on Vegetation for Erosion and Sediment Control under Inoculation of Legumes.

Plant seed uniformly with a cyclone seeder, a drill seeder, a cultipacker seeder, or by hand on a fresh, firm, friable seedbed. If the seedbed has been sealed by rainfall, it should be disked so the seed will be sown into a freshly prepared seedbed.

When using broadcast-seeding methods, subdivide the area into workable sections and determine the amount of seed needed for each section. Apply one-half the seed while moving back and forth across the area, making a uniform pattern; then apply the second half in the same way, but moving at right angles to the first pass.

Cover broadcast seed by raking or chain dragging; then firm the surface with a roller or cultipacker to provide good seed contact. Small grains should be planted no more than 1" deep and grasses and legume seed no more than 1/2" deep.

Hydroseeding

Surface roughening is particularly important when hydroseeding, as a roughened slope will provide some natural coverage for lime, fertilizer, and seed. The surface should not be compacted or smooth. Fine seedbed preparation is not necessary for hydroseeding operations; large clods, stones, and irregularities provide cavities in which seeds can lodge.

Mix seed, inoculant if required, and a seed carrier with water and apply as a slurry uniformly over the area to be treated. The seed carrier should be a cellulose fiber, natural wood fiber or other approved fiber mulch material which is dyed an appropriate color to facilitate uniform application of seed. Use the correct legume inoculant at 4 times the recommended rate when adding inoculant to a hydroseeder slurry. The mixture should be applied within one hour after mixing to reduce damage to seed.

Fertilizer should not be mixed with the seed-inoculant mixture because fertilizer salts may damage seed and reduce germination and seedling vigor.

Fertilizer may be applied with a hydroseeder as a separate operation after seedlings are established.

Lime is not normally applied with a hydraulic seeder because it is abrasive but if necessary it can be added to the seed slurry and applied at seeding or it may be applied with the fertilizer mixture. Also, lime can be blown onto steeper slopes in dry form.

Sprigging

Hybrid bermudagrass cannot be grown from seed and must be planted vegetatively. Vegetative methods of establishing common and hybrid bermudagrass, centipede grass and zoysia include sodding, plugging, and sprigging (see Sodding practice).

When sprigs are planted with a sprigging machine, furrows should be 4-6" deep and 2 feet apart. Place sprigs no farther than 2 feet apart in the row and so that at least one rooting node is in the furrow.

When broadcasting is used for sprig planting, broadcast sprigs at the specified rate (Table PS-1). Press into the top ½" to 2" of soil with a cultipacker or with a disk set nearly straight so that the sprigs are not brought back to the surface. A mulch tacking machine may be used to press sprigs into the soil.

Mulching

The use of mulch provides instant cover and helps ensure establishment of vegetation under normal conditions and is essential to seeding success under harsh site conditions (see Mulching practice). Harsh site conditions include: slopes steeper than 3:1 and adverse soils (shallow, rocky, or high in clay or sand). Areas with concentrated flow should be treated differently and require sod, a hydromulch formulated for channels or an appropriate erosion control blanket.

Irrigation

Moisture is essential for seed germination and vegetation establishment. Supplemental irrigation can be very helpful in assuring adequate stands in dry seasons or to speed development of full cover. It is a requirement for establishment of vegetation from sod and sprigs and should be used elsewhere when feasible. However, irrigation is rarely critical for low-maintenance vegetation planted at the appropriate time of the year.

Water application rates must be carefully controlled to prevent runoff. Inadequate or excessive amounts of water can be more harmful than no supplemental water.

Maintenance

Generally, a stand of vegetation cannot be determined to be fully established until soil cover has been maintained for 1 full year from planting. Inspect vegetated areas for failure and make necessary repairs and vegetate as soon as possible.

If a stand has inadequate cover, reevaluate choice of plant materials and quantities of lime and fertilizer. Re-establish the stand after seedbed preparation or over-seed the stand. Consider a temporary seeding if the time of year is not appropriate for establishment of permanent vegetation (see Temporary Seeding practice).

If vegetation fails to grow, a soil test should be made to determine if soil acidity or nutrient imbalance is responsible.

To attain complete establishment, fertilization is usually required in the second growing season. Turf grasses require annual maintenance fertilization. Use soil tests if possible or follow the guidelines given for the specific seeding mixtures.

Protect vegetation during its establishing period from traffic that will be harmful. If appropriate, use either temporary fences or barriers to protect areas that may be damaged by excessive traffic.

This Page Intentionally Left Blank

Preservation of Vegetation (PV)



Practice Description

Preservation of vegetation is the avoidance of an area during land disturbing and construction activity to prevent mechanical and other injury to desirable plants in the planned landscape. The practice provides erosion and sediment control and is applicable where vegetative cover is desired, and the existing plant community is compatible with the planned landscape.

Planning Considerations

Preservation of vegetation requires good site management to minimize the impact of construction activities on existing vegetation.

Plants to save should be identified prior to any construction activity.

Proper maintenance, especially during construction, is important to ensure healthy vegetation that can control erosion.

Different species, soils, and climatic conditions will require different maintenance activities.

Design Criteria

Plant Protection

Groups of plants and individual trees to be retained should be located on a plan map (see Figure PV-1). Limits of clearing should be planned outside the drip line of groups or individual trees to be saved.

Flagging or other appropriate means of marking the site of the groups of plants and individual trees to be retained should be required before construction begins. Individual trees to be retained should be marked with a highly visible paint or surveyor's ribbon in a band circling the tree at a height visible to equipment operators.

Restrict construction equipment, vehicular traffic, stockpiles of construction materials, topsoil etc., from the areas where plants are retained and restrict these activities from occurring within the drip line of any tree to be retained. Trees being removed shall not be pushed into trees to be retained. Equipment operators shall not clean any of their equipment by slamming it against trees to be retained.

Restrict burning of debris within 100 feet of the plants being preserved. Fires shall be limited in size to prevent damage to any nearby trees.

Toxic material shall not be stored any closer than 100 feet to the drip line of any trees to be retained. Toxic materials shall be managed and disposed of according to state laws.

Fencing and Armoring

The following types of fencing or armoring may be used:

- Board Fence-Board fence may be constructed with 4" square posts set securely in the ground and protruding at least 4 feet above the ground. A minimum of 2 horizontal boards should be placed between the posts. The fence should be placed at the limits of the clearing around the drip line of the tree. If it is not practical to erect a fence at the drip line, construct a triangular fence near the trunk. The limits of clearing will still be the drip line as the root zone within the drip line will still require protection.
- Cord Fence-Posts at least 2" square or 2" in diameter set securely in the ground and protruding at least 4 feet above the ground shall be placed at the limits of clearing with 2 rows of cord ¼" or thicker at least 2 feet apart running between posts with strips of surveyor's tape tied securely to the string at intervals of 3 feet or less.
- Earth Berms-Temporary earth berms may be constructed. The base of the berm on the tree side should be located along the limits of clearing. Earth berms may not be used for this purpose if their presence will create drainage patterns that cause erosion.
- Additional Trees-Additional trees may be left standing as protection between the trees to be retained and the limits of clearing. However, for this alternative to be used, trees in the buffer must be no more than 6 feet apart to prevent passage of equipment and material through the buffer.
- Plan for these additional trees to be evaluated prior to the completion of construction and either given sufficient treatment to ensure survival or be removed.

- Trunk Armoring-As a last resort, a tree may be armored with burlap wrapping and 2” studs wired vertically no more than 2” apart to a height of 5 feet. The armoring should encircle the tree trunk. Nothing should ever be nailed to a tree. The root zone within the drip line will still require protection.
- Fencing and armoring devices should be in place before any construction work is done and should be kept in good condition for the duration of construction activities. Fencing and armoring should not be removed until the completion of the construction project.

Raising the Grade

When the ground level must be raised around an existing tree or group of trees several methods may be used to insure survival.

A well may be created around a group of trees or an individual tree slightly beyond the drip line to retain the natural soil around the feeder roots (see Figure PV-2). When the well alternative is not practical or desirable, remove vegetation and organic matter from beneath the tree or trees for 3 feet beyond the drip line and loosen the surface soil to a depth of approximately 3” without damaging the roots.

Apply fertilizer in the root area of the tree to be retained. A soil test is the best way to determine what type of fertilizer to use. In the absence of a soil test, fertilizer should be applied at the rate of 1 to 2 pounds of 10-8-6 or 10-6-4 per inch of diameter at breast height (dbh) for trees under 6” dbh and at the rate of 2 to 4 pounds of 10-8-6 or 10-6-4 per inch of dbh for trees over 6” dbh.

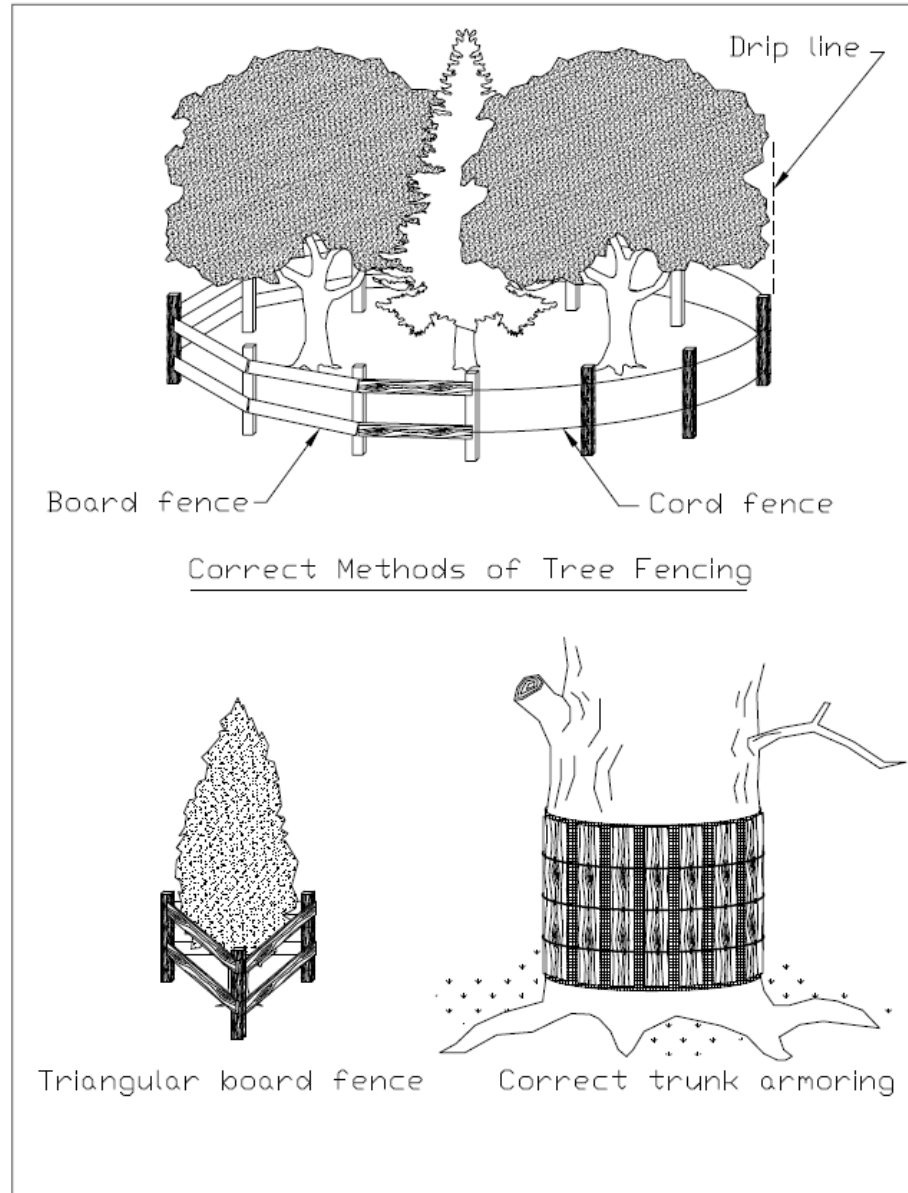

Figure PV-1 Fencing and Armoring

A dry well shall be constructed to allow for tree trunk diameter growth. A space of at least 1 foot between the tree trunk and the well wall is adequate for old, slow growing trees. Clearance for younger trees shall be at least 2 feet. The well shall be high enough to bring the top just above the level of the proposed fill. The well wall shall taper slightly away from the tree trunk at a rate of 1" per foot of wall height.

The well wall shall be constructed of large stones, brick, building tile, concrete blocks, or cinder blocks. Openings should be left through the wall of the well to allow for free movement of air and water. Mortar shall only be used near the top of the well and only above the porous fill.

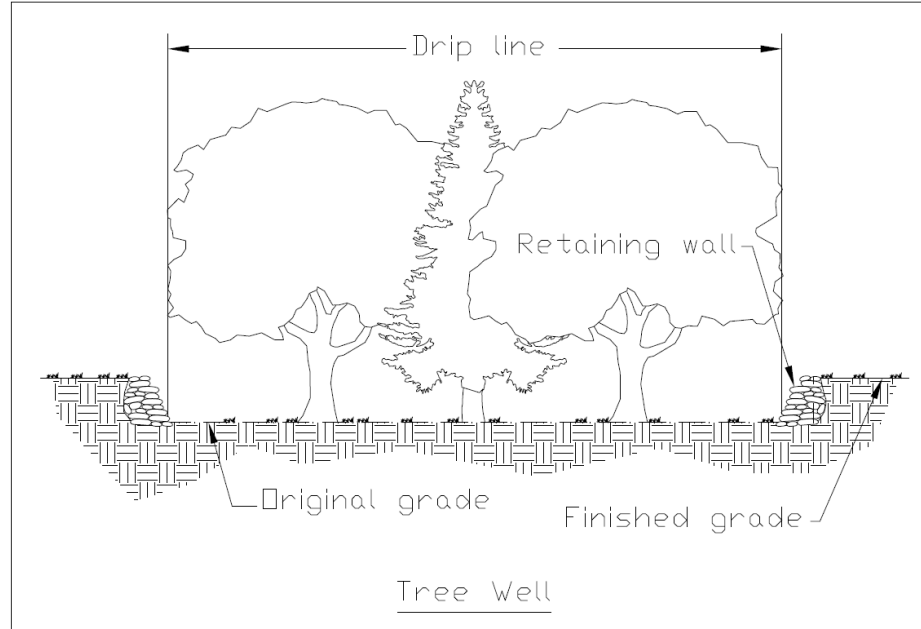

Figure PV-2 Tree Well

Drain lines composed of 4" high quality drain tiles shall begin at the lowest point inside the well and extend outward from the tree trunk in a wheel and spoke pattern with the trunk as the hub (see Figure PV-3). Radial drain lines shall slope away from the well at a rate of $\frac{1}{8}$ " per foot. The circumference line of tiles should be located beneath the drip line of the trees. Vertical tiles or pipes shall be placed over the intersections of the two tile systems if a fill of more than 2 feet is contemplated. Vertical tiles shall be held in place with stone fill. Tile joints shall be tight. A few radial tiles shall extend beyond each intersection and shall slope sharply downward to insure good drainage. Tar paper or its approved equivalent shall be placed over the tile and/or pipe joints to prevent clogging and large stone shall be placed around and over drain tiles and/or pipes for protection.

A layer of 2" to 6" of stone shall be placed over the entire area under the tree from the well outward at least as far as the drip line. For fills up to 2 feet deep, a layer of stone 8" to 12" thick should be adequate.

A thick layer of this stone not to exceed 30" will be needed for deeper fills. A layer of $\frac{3}{4}$ " to 1" stone covered by straw, fiberglass mat or a manufactured filter fabric shall be used to prevent soil from clogging the space between stones. Cinders shall not be used as fill material. Filling shall be completed with porous soil such as topsoil until the desired grade is reached. This soil shall be suitable to sustain specified vegetation.

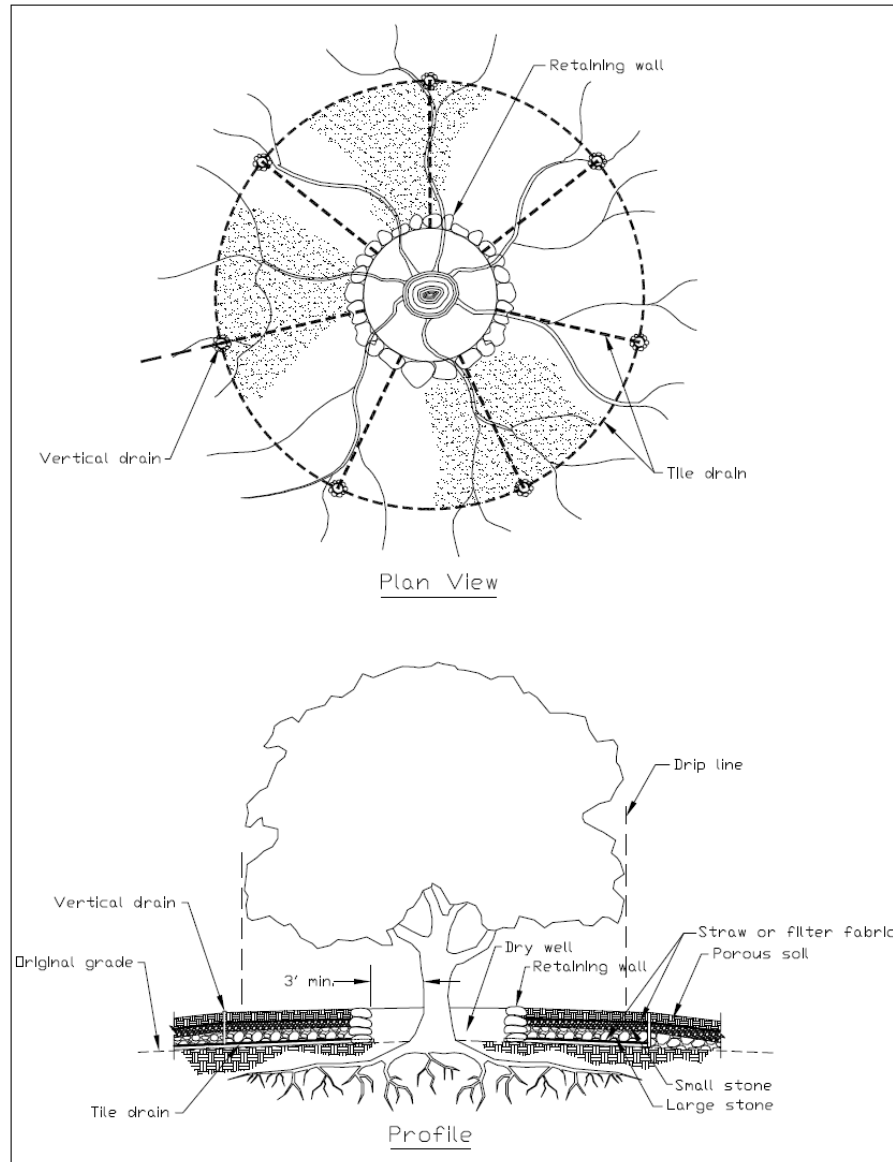

Figure PV-3 Tree Well Detail

Crushed stone shall be placed inside the dry well over the openings of the radial tiles to prevent clogging. The area between the trunk and the well wall shall either be covered by an iron grate or filled with a 50-50 mixture of crushed charcoal and sand to prevent anyone from falling into the dry well.

Where water drainage through the soil is not a problem, coarse gravel in the fill may be substituted for the tile. This material has sufficient porosity to ensure air drainage. Instead of the vertical tiles or pipes in the system, stones, crushed rock and gravel may be added so that the upper level of these porous materials slants toward the surface in the vicinity below the drip line.

Raising the grade on only one side of a tree or group of trees may be accomplished by constructing only half of one of these systems.

Lowering the Grade

Shrubs and trees shall be protected from the harmful grade cuts by the construction of a tree wall (see Figure PV-4). Following excavation, all tree roots that are exposed and/or damaged shall be trimmed cleanly and covered with moist peat moss, burlap, or other suitable material to keep them from drying out.

The wall shall be constructed of large stones, brick, building tile, concrete block or cinder block. The wall should be backfilled with topsoil, peat moss, or other organic matter to retain moisture and aid in root development. Apply fertilizer and water thoroughly. The tree plants should be pruned to reduce the leaf surface in proportion to the amount of root loss. Drainage should be provided through the wall so water will not accumulate behind the wall. Lowering the grade on one side of the tree or group of trees can be accomplished by constructing only half of this system.

Trenching and Tunneling

Trenching should be done as far away from the trunks of trees as possible, preferably outside the branches or crown spreads of trees, to reduce the amount of root area damaged or killed by trenching activities. When possible, trenches should avoid large roots or root concentrations. This can be accomplished by curving the trench or by tunneling under large roots and areas of heavy root concentration. Tunneling under a species that does not have a large tap root may be preferable to trenching beside it as it has less impact on root systems (see Figure PV-5).

Roots should not be left exposed to the air but should be covered with soil as soon as possible or protected and kept moist with burlap or peat moss until the trench or tunnel can be filled. The ends of damaged and cut roots shall be cut off smoothly and moist peat moss, burlap or topsoil should be placed over the exposed area.

Trenches and tunnels shall be filled as soon as possible. Care should be taken to ensure that air spaces are not left in the soil. Peat moss or other organic matter shall be added to the fill material as an aid to inducing and developing root growth. The tree should be fertilized and mulched to stimulate new root growth and enhance general tree vigor. If a large part of the root system has been damaged the crown leaf surface area should be reduced in proportion to the root damage. This may be accomplished by pruning 20-30 percent of the crown foliage. If the roots are damaged during the winter the crown should be pruned before the next growing season. If roots are cut during the growing season, pruning should be done immediately.

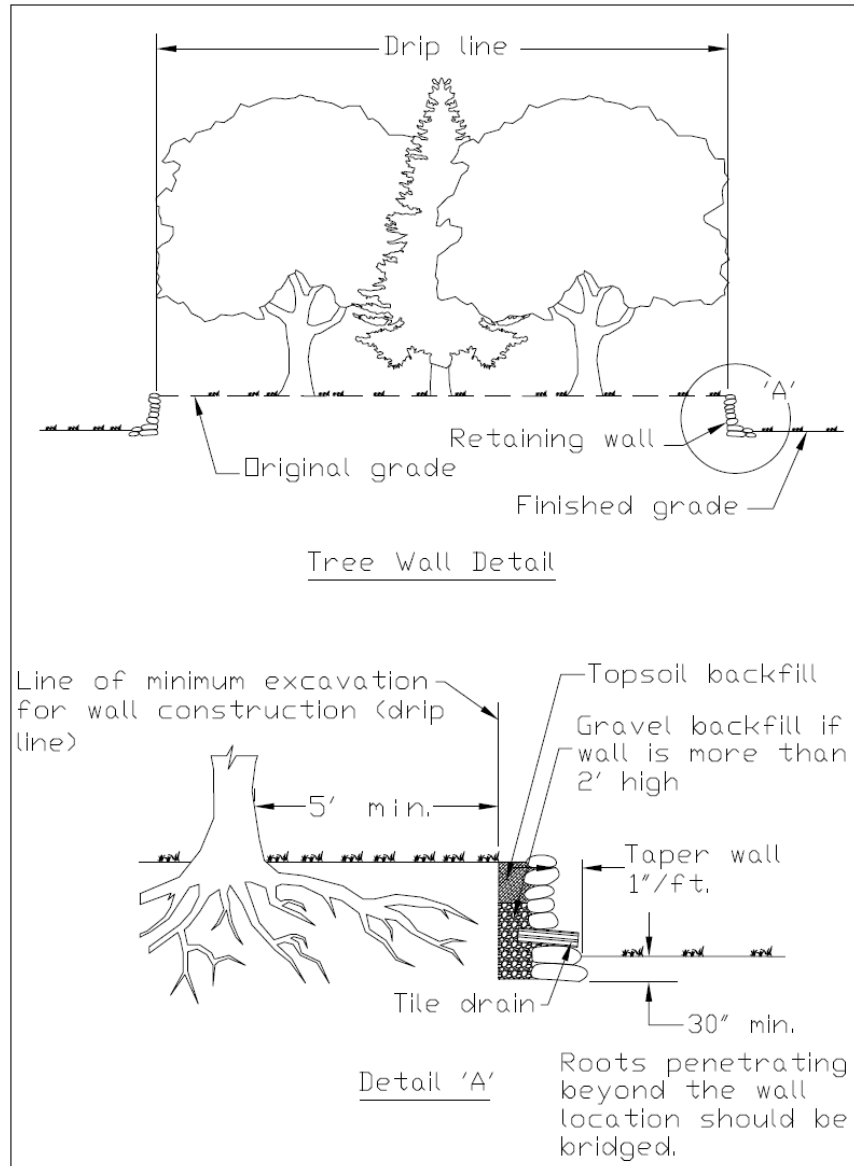

Figure PV-4 Tree Wall Detail

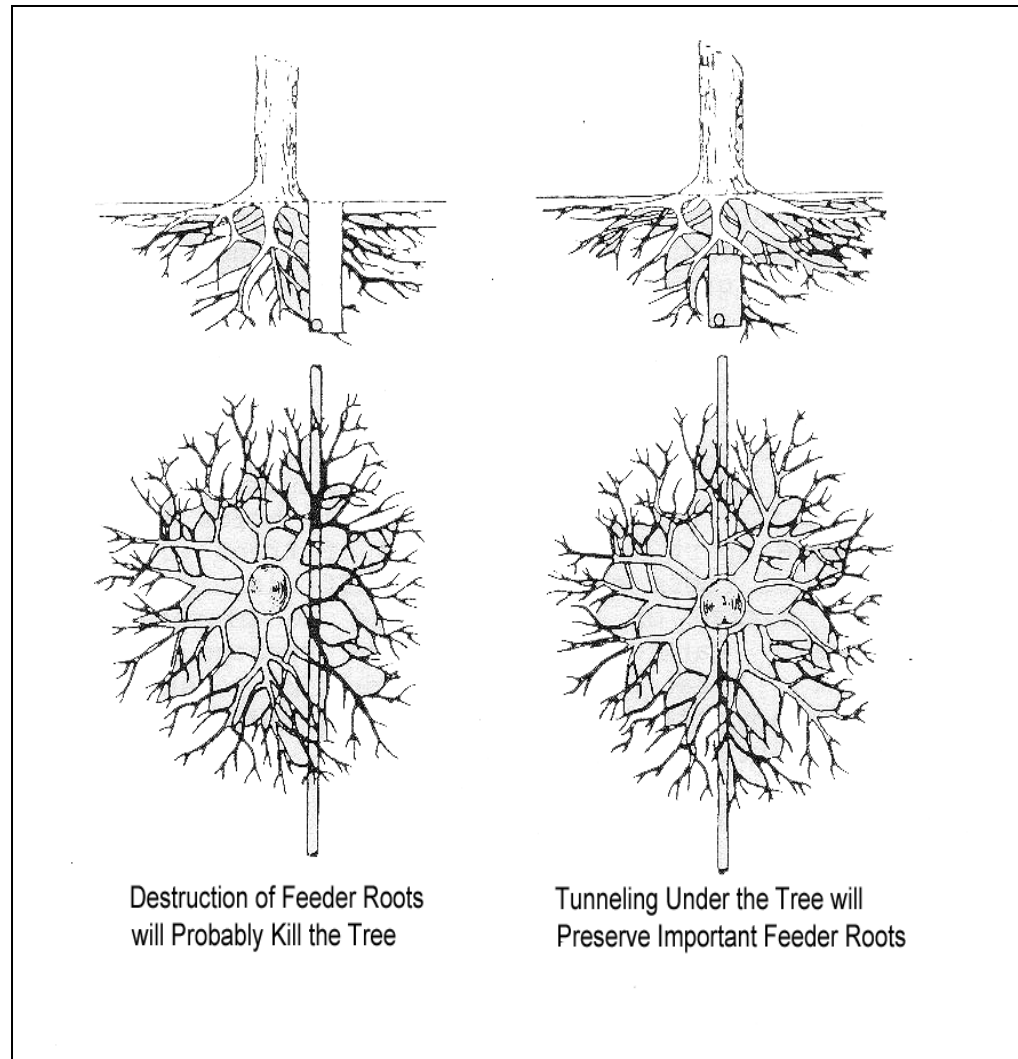

Figure PV-5 Trenching vs Tunneling

Treating Damaged Trees

When trees are damaged during construction activities certain maintenance practices can be applied to protect the health of the tree.

Soil aeration may be needed if the soil has been compacted. The soil around trees can be aerated by punching holes 1 foot deep and 18" apart under the crown of trees with an iron pipe.

Damaged roots should be cut off cleanly and moist peat moss, burlap or topsoil should be placed over the exposed area. Bark damage should be treated by removing loose bark.

Tree limbs damaged during construction or removed for any other reason shall be cut off above the collar at the branch junction.

Trees that have been stressed or damaged should be fertilized to aid their recovery.

Trees should be fertilized in the spring or fall. Fall applications are preferred.

Fertilizer should be applied to the soil over the feeder roots. In no case should it be applied closer than 3 feet to the trunk. Root systems of trees extend some distance beyond the drip line. The area to be fertilized should be increased by $\frac{1}{4}$ the area of the crown. A soil test is the best way to determine what type of fertilizer to use. In the absence of a soil test, fertilizer should be applied at the rate of 1 to 2 pounds of 10-8-6 or 10-6-4 per inch of dbh for trees under 6" dbh and at the rate of 2 to 4 pounds of 10-8-6 or 10-6-4 per inch of dbh for trees over 6" dbh.

A ground cover or organic mulch layer should be maintained around trees to prevent erosion, protect roots and to conserve water.

Retaining Wall (RW)



Practice Description

A retaining wall is a constructed wall used to eliminate steep slopes between areas that have abrupt changes in grade. This practice is used to replace cut or fill slopes in confined areas or where a wall is necessary to achieve stable slopes. A retaining wall can be constructed of reinforced concrete, treated timbers, gabions, reinforced earth (a system of face panels and buried reinforcement strips), and other manufactured products such as interlocking concrete blocks.

Planning Considerations

Retaining walls to stabilize the site should be used in conjunction with steep cut or fill slopes, which may be unstable due to steepness, space limitations, or poor soil conditions to stabilize the site. Retaining walls may be used to relieve the need to construct cuts into steep hillsides or on small lots where fill toe-outs or slope cut-outs would go off of the property being developed. Retaining walls may be required to get the best or intended use of the property.

Retaining walls can be constructed from the following materials:

- Reinforced concrete
- Concrete cribbing

- Geotextile wrapped face wall
- Geotextile reinforced steep slopes
- Modular blocks
- Treated timbers

Each case is different and the type retaining wall to be used should be selected by a qualified design professional based on the particular site conditions and what best meets the needs of the site. In most cases treated timber is the least desirable material because of its potential to decay.

Design Criteria

The design of a retaining wall is or can be a complicated engineering procedure. There are many factors to consider. Each case is different and requires a different set of considerations and a different design.

The qualified design professional should consider the stresses and forces outside and within the wall as well as allowable height and minimum thickness. Other considerations are foundation design with respect to loadings, bearing values of soils, drainage aspects, and footing dimensions.

Additional design factors include safety hazards and appearance.

Each retaining wall requires a specific engineering design which requires the capabilities of a competent qualified design professional. Retaining walls are engineering structures which affect public property, life, and welfare of citizens. Alabama law which regulates the practice of professional engineering in the State of Alabama must be followed on structures such as retaining walls. The State Board of Registration for Professional Engineers and Land Surveyors in Montgomery is responsible for administering the provisions of the law.

Shrub, Vine and Groundcover Planting (SVG)



Practice Description

Shrub, vine and groundcover planting is establishing shrubs, vines or groundcover to stabilize landscapes where establishing grass is difficult and mowing is not feasible. The practice is especially suited for steep slopes where aesthetics are important. Incidental benefits include providing food and shelter for wildlife, windbreaks or screens, and improved aesthetics.

Planning Considerations

Shrubs, vines, and groundcovers provide alternatives to grasses and legumes as low-maintenance, long-term erosion control. However, they are normally planted only for special, high-value applications, or for aesthetic reasons, because there is additional cost and labor associated with their use.

Very few of these plants can be dependably planted from seed, and none are capable of providing the rapid cover possible with grasses. Consequently, short-term stabilization efforts must involve using dependable mulch along with special cultural practices to ensure establishment.

Shrubs vary in form and differ from most trees in that multiple stems arise from a common base.

Shrubs can be used to attain additional benefits including the following:

- Increase the aesthetic value of plantings
- Provide visual screening and protective barriers
- Enhance windbreaks
- Provide food and cover for wildlife

- Accelerate the transition to a diverse landscape
- Provide post-construction landscaping

Groundcovers differ in growth rate and shade tolerance. Some are suitable only as part of a high-maintenance landscape; others can be used to stabilize large areas with little maintenance.

Competition from volunteer plants inhibits development and maintenance of the groundcover. Thick durable mulch such as shredded bark (not chips) or pine straw can prevent erosion and reduce weed competition.

Mulch is beneficial to plants at most stages of development but is particularly important for new plantings.

Design Criteria

Plant Selection

Specific characteristics and requirements of recommended species are given in Tables SVG-1 through SVG-5 Plants Suitable for Shrub, Vine and Groundcover Planting in Alabama. Other suitable plants may be identified by qualified design professionals based on plant suitability information including plant adaptation zones (see Figure SVG-1). Exotic invasive species should not be planted!

Site Preparation

Remove debris and other undesirable objects and smooth the area to accommodate the planting and mulching. Sites should be prepared in strips along the contour or at individual spots. Additional preparation will vary according to the type of plant and is discussed later under Planting.

Soil Amendments

Fertilizer and lime requirements are plant specific and the prescription for a planting should be based on a soil test or a plan prepared by a qualified design professional.

Soils low in organic matter may be improved by incorporating peat, compost, aged sawdust, or well-rotted manure.

To eliminate competition from weeds, an appropriate preemergent herbicide may be useful if mechanical weeding is not practical or desired.

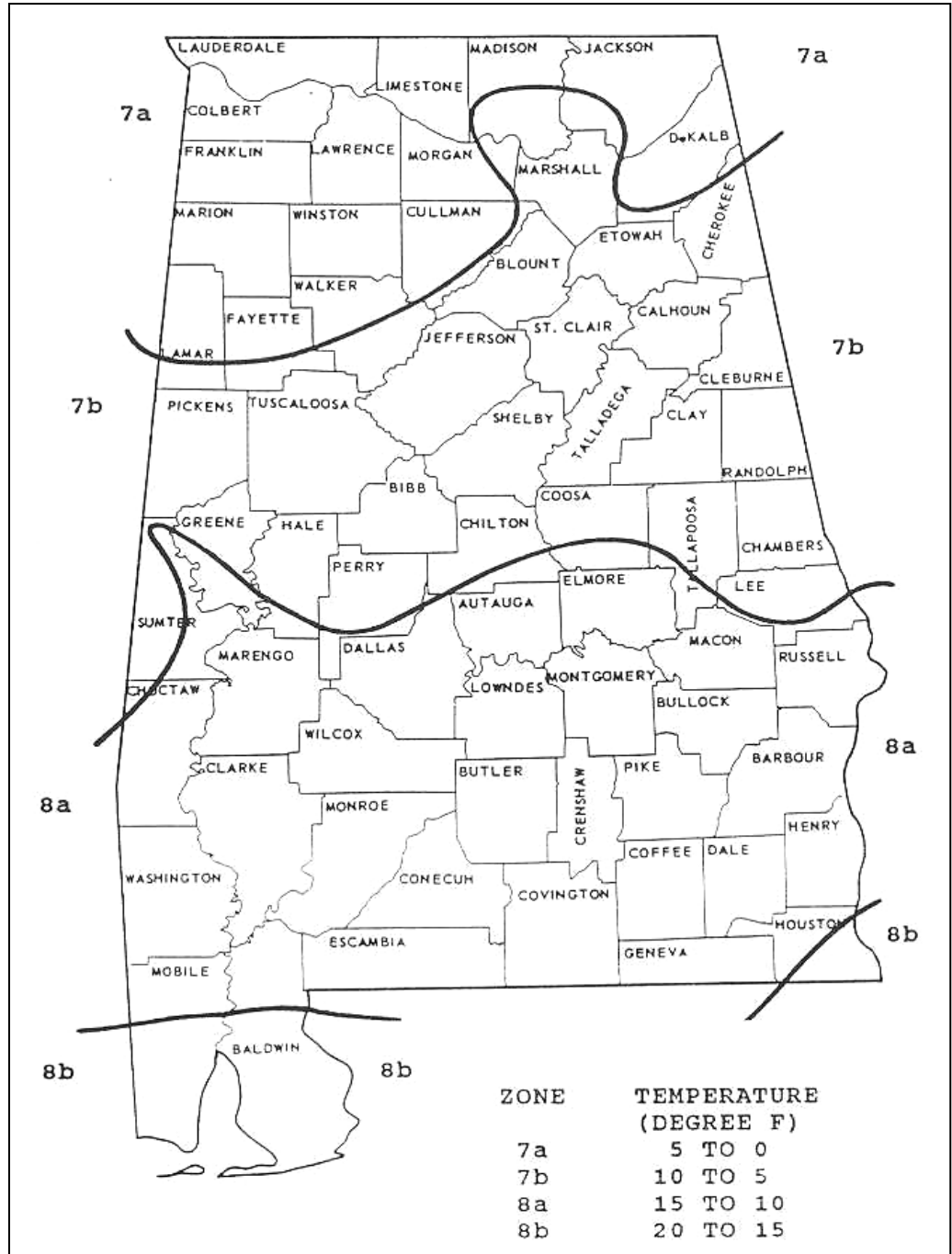

Figure SVG-1 Plant Adaptation Zones

Table SVG-1 Plants Suitable for Vine and Groundcover Planting in Alabama

Botanical Name and Common Name	Normal Height	Growth Rate ¹	Group ²	Exposure ³
<i>Bignonia capreolata</i> * Crossvine	50 ft.	M	E	S-PS
<i>Boltonia asteroides</i> False Aster	5-6 ft.	S-M	D	S
<i>Decumaria Barbara</i> * Climbing Hydrangea	12-36 ft.	M	D	PS
<i>Dryopteris ludoviciana</i> Southern Woodfern	3-4 ft.	S-M	E	Sh
<i>Gelsemium sempervirens</i> * Yellow Jessamine	10-20 ft.	M-F	E	S-PS
<i>Hemerocallis</i> sp. Daylily	12-36 in.	M	D	S-PS
<i>Heuchera</i> spp. Heuchera Hybrids/ Alumroot	12-18 in.	M	D	PS
<i>Hypericum calycinum</i> St. Johnswort	12-18 in.	M	E	S-PS
<i>Iris cristata</i> Dwarf Crested Iris	6-12 in.	F	D	PS-Sh
<i>Juniperus conferta</i> Blue Pacific Shore Juniper	12-18 in.	F	E	S
<i>Juniperus horizontalis</i> Creeping Juniper	12-24 in.	M	E	S
<i>Lonicera sempervirens</i> * Coral Honeysuckle	15-20 ft.	M	E	S-PS
<i>Phlox divaricata</i> Creeping Phlox	6-12 in.	F	D	PS-Sh
<i>Phlox subulata</i> Moss Phlox or Thrift	4-6 in.	M	E	S
<i>Osmunda cinnamomea</i> Cinnamon Fern	2-3 ft.	M	D	PS-Sh
¹ Growth Rate: S=slow M=medium, F=fast ² Group: D=deciduous, E=evergreen ³ Exposure: S=sun, PS=part shade, Sh=shade * Denotes plants used as vines.				

Table SVG-2 Plants Suitable for Small Shrub (2-5 ft.) Planting in Alabama

Botanical Name and Common Name	Normal Height	Growth Rate ¹	Group ²	Exposure ³
<i>Abelia x grandiflora</i> 'Prostrata' Prostrate Abelia	2-3 ft.	M	E	S
<i>Baptisia</i> spp. Blue Wild Indigo	2-4 ft.	M	D	S
<i>Chaenomoles speciosa</i> Flowering Quince	3-5 ft.	M-F	D	S-PS
<i>Ilex cornuta</i> 'Carissa' Carissa Holly	3-4 ft.	S	E	S-PS
<i>Ilex cornuta</i> 'Rotunda' Rotunda Holly	3-4 ft.	S	E	S-PS
<i>Ilex crenata</i> 'Compacta' Compacta Holly	4-5 ft.	S	E	S-PS
<i>Ilex crenata</i> 'Green Lustre' Green Lustre Holly	3-4 ft.	M	E	S-PS
<i>Ilex vomitoria</i> 'Nana' Dwarf Yaupon Holly	3-4 ft.	S	E	S-PS
<i>Itea virginica</i> Virginia Sweetspire	3-5 ft.	M-F	E	S-Sh
<i>Jasminum floridum</i> * Showy Jasmine	4-5 ft.	M	E	S-Sh
<i>Jasminum nudiflorum</i> Winter Jasmine	3-4 ft.	F	D	S-Sh
<i>Juniperus horizontalis</i> 'Plumosa' Andorra Juniper	2-3 ft.	S-M	E	S
<i>Leucothoe axillaris</i> Coastal Leucothoe	2-4 ft.	S-M	E	PS-Sh
<i>Raphiolepis indica</i> * Indian Hawthorn	3-4 ft.	S	E	S
<i>Santolina chamaecyparissus</i> Lavender Cotton	2-4 ft.	S	E	S
<i>Spiraea x bumalda</i> 'Anthony Waterer' Anthony Waterer Spirea	3-4 ft.	F	D	S-PS
<i>Spiraea japonica</i> 'Little Princess' Little Princess Spirea	2-3 ft.	M	D	S
¹ Growth Rate: S=slow M=medium, F=fast ² Group: D=deciduous, E=evergreen ³ Exposure: S=sun, PS=part shade, Sh=shade * For use in Southern half of state.				

Table SVG-3 Plants Suitable for Medium Shrub (5-8 ft.) Planting in Alabama

Botanical Name and Common Name	Normal Height	Growth Rate ¹	Group ²	Exposure ³
<i>Abelia x grandiflora</i> Glossy Abelia	4-5 ft.	M-F	E	S-PS
<i>Callicarpa americana</i> American Beautyberry	3-8 ft.	M-F	D	S-PS
<i>Clethra alnifolia</i> Summersweet Clethra	4-8 ft.	S-M	D	S-PS
<i>Euonymus americanus</i> Brook Euonymus / Hearts-a-busting	4-6 ft.	M	D	PS
<i>Euonymus alatus</i> 'Compactus' Dwarf Winged Euonymus	5-6 ft.	S	D	S-PS
<i>Forsythia x intermedia</i> Border Forsythia	8-10 ft.	F	D	S
<i>Hydrangea quercifolia</i> Oakleaf Hydrangea	6-8 ft.	S-M	D	S-PS
<i>Ilex cornuta</i> 'Burfordii Nana' Dwarf Burford Holly	6-7 ft.	S	E	S-PS
<i>Ilex glabra</i> Inkberry Holly	6-8 ft.	S	E	S-Sh
<i>Illicium anisatum</i> Japanses Anise Tree	6-10 ft.	M-F	E	PS
<i>Illicium floridanum</i> Florida Anise Tree	6-10 ft.	M-F	E	PS-Sh
<i>Physocarpus opulifolius</i> Ninebark	6-10 ft.	M	D	S-PS
<i>Viburnum dentatum</i> Arrowwood Viburnum	6-8 ft.	M-F	D	S-PS
¹ Growth Rate: S=slow M=medium, F=fast ² Group: D=deciduous, E=evergreen ³ Exposure: S=sun, PS=part shade, Sh=shade				

Table SVG-4 Plants Suitable for Large Shrub (8 ft. and up) Planting in Alabama

Botanical Name and Common Name	Normal Height	Growth Rate ¹	Group ²	Exposure ³
<i>Aescula parviflora</i> Bottlebrush Buckeye	8-12 ft.	S-M	D	S-PS
<i>Agarista populifolia</i> Pipestem Plant	8-12 ft.	M-F	E	Sh
<i>Calycanthus floridus</i> Sweetshrub	8-10 ft.	M	D	S-Sh
<i>Ilex cornuta</i> "Burfordii" Burford Holly	10-15 ft.	M	E	S-Sh
<i>Morella cerifera</i> * Southern Waxmyrtle	8-10 ft.	M	E	S-PS
<i>Ternstroemia gymnanthera</i> Cleyera	8-10 ft.	S	E	PS-Sh
<i>Viburnum lantana</i> Wayfaringtree Viburnum	10-15 ft.	M	D	S-PS
<i>Viburnum plicatum</i> var. <i>tomentosum</i> ** Doublefile Viburnum	8-10 ft.	M	D	PS
<i>Viburnum x pragense</i> Prague Viburnum	8-10 ft.	M	D	S-PS
¹ Growth Rate: S=slow M=medium, F=fast ² Group: D=deciduous, E=evergreen ³ Exposure: S=sun, PS=part shade, Sh=shade * For use in southern half of the state. ** For use in the northern half of the state.				

Table SVG-5 Plants Suitable for Ornamental Grass Planting in Alabama

Botanical Name and Common Name	Height and Spread	Exposure ¹
<i>Andropogon gerardii</i> Big Blue Stem	4-6 ft	S
<i>Carex pensylvanica</i> Pennsylvania Sedge	2-3 ft.	PS
<i>Carex stricta</i> Upright Sedge	1-3 ft.	S
<i>Chasmanthium latifolium</i> River Oats	2-4 ft.	PS-Sh
<i>Deschampsia flexuosa</i> * Crinkle Hair Grass	6-12 in.	PS
<i>Muhlenbergia capillaries</i> Muhly Grass	2-3 ft.	S-Sh
<i>Panicum virgatum</i> Switchgrass	3-6 ft.	S-PS
¹ Exposure: S=sun, PS=part shade, Sh=shade * For use only in the northern half of the state.		

Planting

Individual Shrubs with Root Ball

Provide a relatively large area for initial root development. The hole should be dug to a depth that allows the root ball to extend 1" above the soil surface and should be as big around as 3 to 5 times the diameter of the root ball. As soil is added the hole should be filled with water until the filling of the hole is complete.

Shrubs in Prepared Beds

Till or spade a bed to a depth of 8" to 12". Contrary to the individual planting, soil amendments, such as peat or compost at a rate of 1 part amendment to 3 parts native soil, are beneficial to shrubs because they provide a uniform root environment across the bed area. Organic soil amendments enable plants to respond positively to water and fertilizers when they are applied. The hole for the shrub planted in a bed area should be a few inches wider in diameter than the root ball.

Plants in Containers

Remove container plants from their containers, cutting the container if necessary. If the plant is root-bound (roots circling the outside of the root ball), score the roots from top to bottom about 4 times, cutting about ¼ inch deep with a knife, or gently massage the root ball until roots point outward. Place the shrub into the hole. Using only the native backfill, add soil back to the hole until it is ½ to ⅔ full. Water in the backfill soil around the root ball. Add soil to ground level and

thoroughly water again. A small dike may be formed around the edge of the planting hole to hold water around the root ball if in sandy soils or on slopes. *Caution: in a dense clay soil, trapping additional water in the root zone can be detrimental because water drains poorly and creates an extended period of wetness.*

Bare Root Plants

Soak bare root plants in water. When planting, spread the roots in the hole and gradually add soil. Firm the soil, being careful to avoid breaking roots. Fill the hole with water and allow it to drain. Then fill the hole with soil, and water again thoroughly.

Burlapped Plants

Cut any wire or string that is around plants stems. Do not remove the burlap. Fold the burlap back so it will be buried by soil. Burlap which is allowed to remain exposed after planting can act as a wick, causing the root ball to dry out. Follow the same procedure for filling the hole as that described for container plants.

Vine and Groundcovers

Most groundcovers are planted from container-grown nursery stock. Planting density determines how quickly full cover is achieved; a 1 foot spacing is often used for rapid cover. Large plants such as junipers can be spaced on 3-foot centers. Transplanting to the prepared seedbed can be done using a small trowel or a spade. Make a hole large enough to accommodate the roots and soil. Backfill and firm the soil around the plant, water immediately, and keep well-watered until established. Water slowly and over longer periods to allow for infiltration and reduce runoff.

When to plant

Late winter (before leaves emerge) is the best time for planting deciduous shrubs and early fall is the best for evergreen shrubs. Shrubs grown in containers can be planted anytime during the year except when the ground is frozen.

Shrubs, vines and groundcovers are best planted in early fall or early spring. Plantings made at other times are likely to encounter periods of drought or cold weather that may affect survivability

Mulching

Once plants are installed, add mulch. On steep slopes or highly erodible soils, install erosion control netting or matting prior to planting, and tuck plants into the soil through slits in the net. Plant in a staggered pattern (see Mulching practice for more details on mulching).

Watering

Shrubs, vines, and groundcovers need about an inch of water a week for the first 2 years after planting. When rain does not supply this need, plants should be watered. Shrubs should be watered deeply and not more than once a week. Vines and groundcover should be watered more frequently during the first few months in the area over and beyond the root ball if rainfall does not supply 1" of water per week.

Sodding (SOD)



Practice Description

Sodding is transplanting harvested sod to provide immediate ground cover. Sodding is well suited for stabilizing erodible areas such as grass-lined channels, slopes around storm drain inlets and outlets, diversions, swales, and slopes and filter strips that cannot be established by seed or that need immediate cover.

Planning Considerations

Advantages of sod include immediate erosion control, nearly year-round establishment capability, less chance of failure than with seeding, and rapid stabilization of surfaces for traffic areas, channel linings, or critical areas.

Initially, it is more costly to install sod than to plant seed; however, the higher cost may be justified for specific situations where sod performs better than a seeded cover. Sodding may be more cost-efficient in the long term.

Sod can be laid during the times of the year when seeded grasses may fail, provided there is adequate water available for irrigation in the early establishment period. Irrigation is essential, at all times of the year, to ensure establishment of sod.

Sod placed around drop inlets can prevent erosion around the inlet and help maintain the necessary grade around the inlet.

The site to be sodded should be prepared for the sod before it is delivered so that the sod can be installed immediately. Leaving sod stacked or rolled can cause severe damage and loss of plant material.

Failure to remove compaction and to address pH and soil fertility deficiencies will likely cause a sodded stand to perform poorly or fail.

Design Criteria

Sod Selection

The species of sod selected should be adapted to both the site and the intended purpose. Species used in Alabama include bermuda, zoysia, centipede, St. Augustine, tall fescue, and bahiagrass. Tall fescue and bahiagrass are not readily available but can be obtained from some growers. Species selection is primarily determined by region, availability, and intended use. Use Table SOD-1 and Figure SOD-1 for guidance in selecting sod.

Table SOD-1 Grasses Adapted for Sodding in Alabama

Warm Season Grasses		
Species	Variety ¹	Area Adapted
Bermudagrass	Tifway, TifSport, Celebration, TifGrand, Common	North, Central, South
Bahiagrass	Pensacola	Central, South
Centipede	Common, TifBlair	Central, South
St. Augustine	Common, and a few commercial varieties	South
Zoysia	Any selection available in Alabama, Zenith is seeded	Central, South
Cool Season Grasses		
Tall Fescue	Kentucky 31, Rebel (turf type)	North

¹ Listing of a variety is not an endorsement of a Company product. New and better varieties may become available over time.

Surface Preparation

Prior to laying sod, clear the soil surface of trash, debris, roots, branches, stones, and clods larger than 2" in diameter. Fill or level low spots to avoid standing water. Rake or harrow the site to achieve a smooth and mowable final grade. Apply appropriate soil amendments prior to final disking. Complete soil preparation by disking, chiseling or other appropriate means and then rolling or cultipacking to firm the soil. Limit the use of heavy equipment on the area to be sodded, particularly when the soil is wet, as this may cause excessive compaction and make it difficult for the sod to penetrate the soil and develop the root system that it should attain.

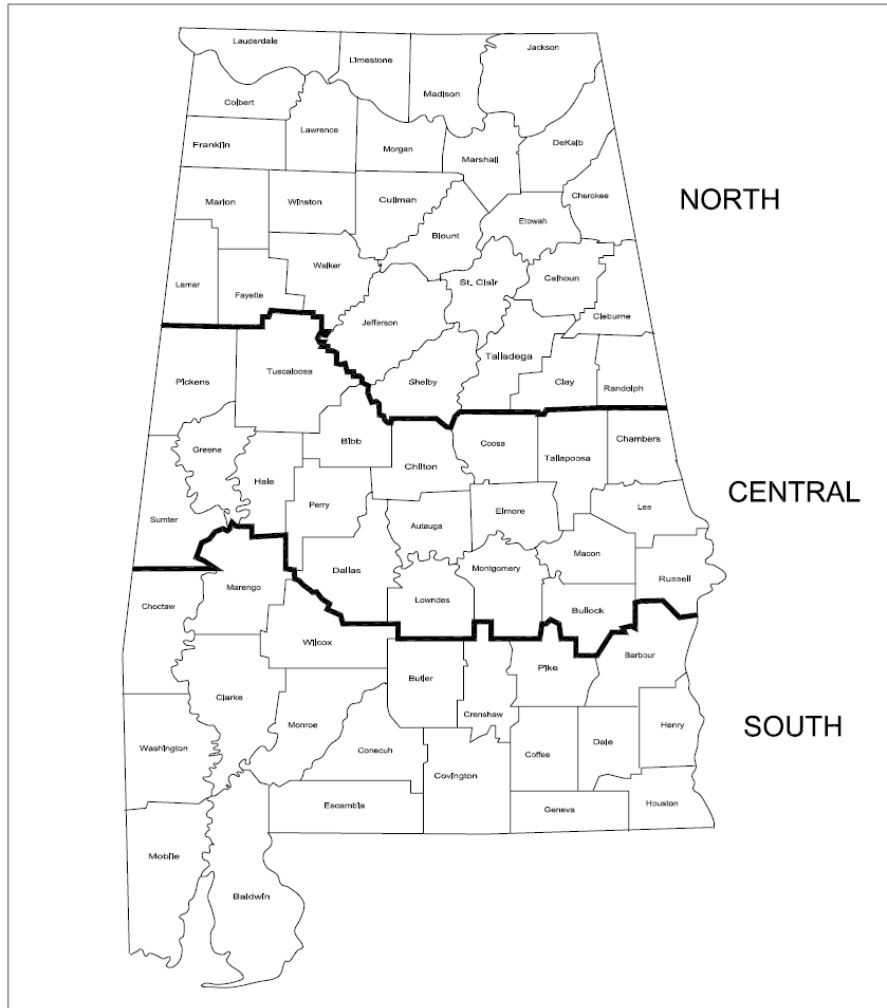

Figure SOD-1 Geographical Areas for Species Adaptation

Soil Amendments

Test soil to determine the requirements for lime and fertilizer. Soil tests may be conducted by Auburn University Soil Testing Laboratory or other laboratories that make recommendations based on soil analysis. When soil test recommendations are unavailable, the following soil amendments may be sufficient:

- Agricultural limestone at a rate of 2 tons per acre (90 lbs per 1000 sq. ft.). Other liming materials that may be selected should be provided in amounts that provide equal value to agricultural lime.
- Fertilizer at a rate of 1000 lbs per acre (25 lbs per 1000 sq. ft.) of 10-10-10.
- Equivalent nutrients may be applied with other fertilizer formulations. The soil amendments should be spread evenly over the treatment area and incorporated into the top 6" of soil by disking, chiseling or other effective, means. If topsoil is applied, follow specifications given in the Topsoiling

practice. Minor surface smoothing may be necessary after incorporation of soil amendments.

Installing the Sod

A step-by-step procedure for installing sod is illustrated in Figure SOD-2 and described below.

Moistening the sod after it is unrolled helps maintain its viability. Store it in the shade during installation.

Rake the soil surface to break the crust just before laying sod. During the summer, lightly irrigate the soil immediately before laying the sod to cool the soil and reduce root burning and dieback.

Do not lay sod on gravel, frozen soils, or soils that have been recently sterilized or treated with herbicides.

Lay the first row of sod in a straight line with subsequent rows placed parallel to and butting tightly against each other. Stagger strips in a brick-like pattern (see Figure SOD – 2). Be sure that the sod is not stretched or overlapped and that all joints are butted tightly to prevent voids. Use a knife or sharp spade to trim and fit irregularly shaped areas.

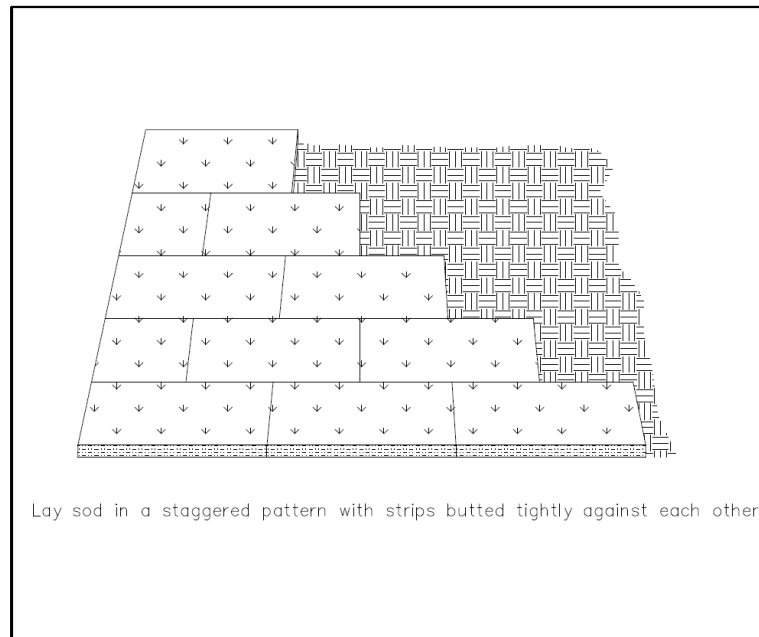

Figure SOD-2 Typical Installation of Grass Sod

Install strips of sod with their longest dimension perpendicular to the slope. On slopes 3:1 or greater, in grass swales or wherever erosion may be a problem, secure sod with pegs or staples. Jute or other netting material may be pegged over the sod for extra protection on critical areas (see Figure SOD – 3). When netting is used consider wildlife friendly netting.

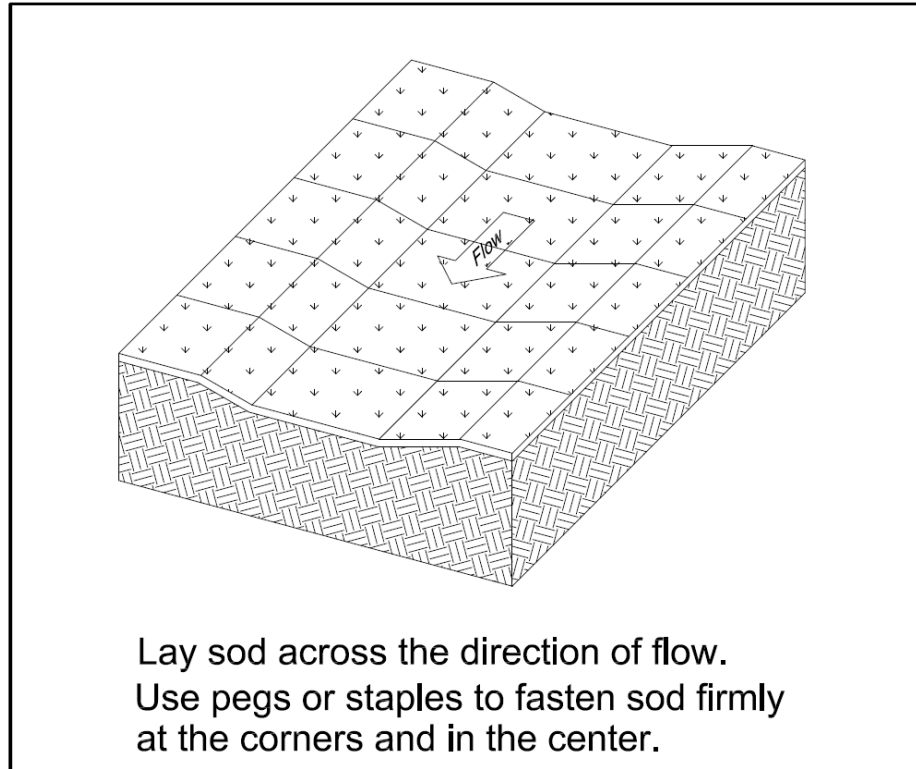

Figure SOD-3 Installation of Sod in Areas with Channel Flows

As sodding of clearly defined areas is completed, use a weighted roller on the sod to provide firm contact between roots and soil.

After rolling, irrigate until the soil is wet at least 6" below the sod.

Keep sodden areas moist to a depth of 4" until the grass takes root. This can be determined by gently tugging on the sod. Resistance indicates that rooting has occurred.

Mowing should not be attempted until the sod is firmly rooted, usually in 2 to 3 weeks.

This Page Intentionally Left Blank

Temporary Seeding (TS)



Practice Description

Temporary seeding is the establishment of fast-growing annual vegetation from seed. Temporary vegetation provides economical erosion control for up to a year and reduces the amount of sediment moving off the site.

This practice applies where short-lived vegetation can be established before final grading or in a season not suitable for planting the desired permanent species. It helps prevent costly maintenance operations on other practices such as sediment basins and sediment barriers. In addition, it reduces problems of mud and dust production from bare soil surfaces during construction. Temporary or permanent seeding is necessary to protect earthen structures such as dikes, diversions, grass-lined channels and the banks and dams of sediment basins.

Planning Considerations

Temporary vegetative cover can provide significant short-term erosion and sediment reduction before establishing perennial vegetation.

Temporary vegetation will reduce the amount of maintenance associated with sediment basins.

Temporary vegetation is used to provide cover for no more than 1 year. Permanent vegetation should be established at the proper planting time for permanent vegetative cover.

Certain plants species used for temporary vegetation will produce large quantities of residue which can provide mulch for establishment of the permanent vegetation.

Proper seedbed preparation and selection of appropriate species are important with this practice. Failure to follow establishment guidelines and recommendations carefully may result in an inadequate or short-lived stand of vegetation that will not control erosion.

The selection of plants for temporary vegetation must be site specific. Factors that should be considered are type of soils, climate, establishment rate, and management requirements of the vegetation. Other factors that may be important are wear, mowing tolerance, and salt tolerance of vegetation.

Seeding properly carried out within the optimum dates has a higher probability of success. It is also possible to have satisfactory establishment when seeding outside these dates. However, as plantings are deviated from the optimum dates, the probability of failure increases rapidly. Seeding dates should be taken into account in scheduling land-disturbing activities.

Site quality impacts both short-term and long-term plant success. Sites that have compacted soils should be modified whenever practical to improve the potential for plant growth.

The operation of equipment is restricted on slopes steeper than 3:1, severely limiting the quality of the seedbed that can be prepared. Provisions for establishment of vegetation on steep slopes can be made during final grading. In construction of fill slopes, for example, the last 4-6" might not be compacted. A loose, rough seedbed with irregularities that hold seeds and fertilizer is essential for hydroseeding. Cut slopes should be roughened (see practice Land Grading).

Appropriate mulching practices are critical to protect against erosion on steep slopes. When using straw, anchor with netting or asphalt. On slopes steeper than 2:1, either hydraulic mulch or erosion control blanket is more appropriate than straw to protect the slope.

The use of irrigation (temporary or permanent) will greatly improve the success of vegetation establishment.

Design Criteria

Plant Selection

Select plants that can be expected to meet planting objectives. To simplify plant selection, use Table TS-1, Commonly Used Plants for Temporary Cover and Figure TS-1, Geographical Areas for Species Adaptation and Seeding Dates. Seeding mixtures commonly specified by the Alabama Department of Transportation are an appropriate alternative for plantings on rights-of-ways. Additional information related to plantings in Alabama is found in Chapter 2 in the sections on Non-Woody Vegetation.

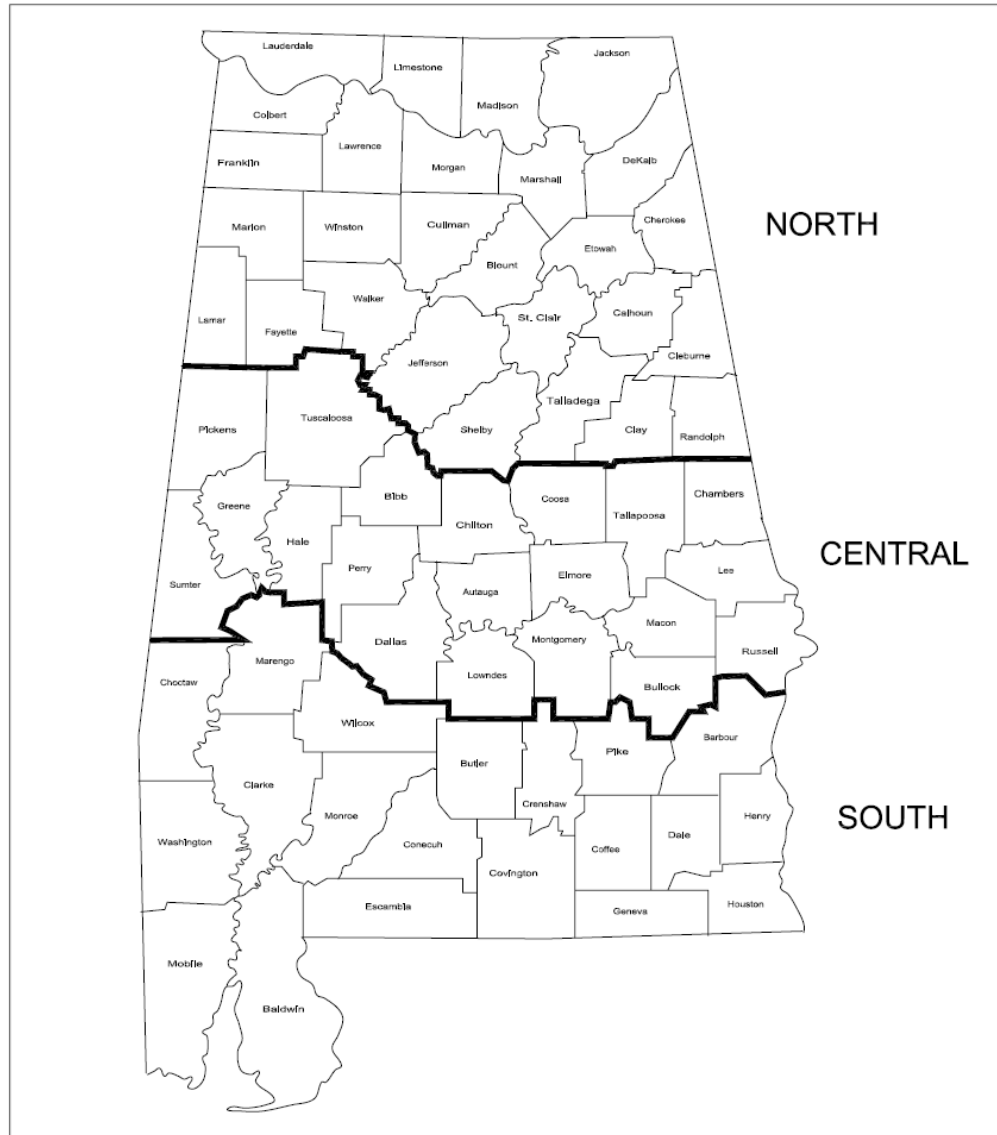

Figure TS-1 Geographical Areas for Species Adaptation and Seeding Dates

Note: Site conditions related to soils and aspect in counties adjacent to or close to county boundaries may justify adjustments in planting dates by qualified design professionals.

Table TS-1 Commonly Used Plants for Temporary Cover¹

Species	Seeding Rate/AC PLS ²	North	Central	South
		Seeding Dates		
Millet, Browntop or German	40 lbs	Apr1-Aug 1	Apr1- Aug 15	Apr 1-Aug 15
Rye	3 bu	Sep 1-Nov 15	Sep 15-Nov 15	Sep 15-Nov 15
Ryegrass	30 lbs	Aug 1-Sep 15	Sep 1-Oct 15	Sep 1-Oct 15
Sorghum-Sudan Hybrids	40 lbs	May 1-Aug 1	Apr 15-Aug 1	Apr 1-Aug 15
Sudangrass	40 lbs	May 1-Aug 1	Apr 15-Aug 1	Apr 1-Aug 15
Wheat	3 bu	Sep 1-Nov 1	Sep 15-Nov 15	Sep 15-Nov 15
Common Bermudagrass	10 lbs	Apr 1-July 1	Mar 15-July 15	Mar 1-July 15
Crimson Clover	10 lbs	Sept 1-Nov 1	Sept 1-Nov 1	Sept 1-Nov 1

1 DO NOT USE Seeding Rates as part of a mixture.

2 PLS means Pure Live Seed and is used to adjust seeding rates. For example, to plant 10 lbs PLS of a species with germination of 80% and purity of 90%, $PLS = 0.8 \times 0.9 = 72\%$. $10\text{lbs PLS} = 10/0.72 = 13.9$ lbs of the species to be planted.

Site Preparation and Soil Amendments

Complete grading and shaping before applying soil amendments if needed to provide a surface on which equipment can safely and efficiently be used to apply soil amendments and accomplish seedbed preparation and seeding.

Lime

Apply lime according to soil test recommendations. If a soil test is not available, use 1 ton of agricultural limestone or equivalent per acre on coarse textured soils and 2 tons per acre on fine textured soils. Do not apply lime to alkaline soils or to areas which have been limed during the preceding 2 years. Other liming materials that may be selected should be provided in amounts that provide equal value to the criteria listed for agricultural lime or be used in combination with agricultural limestone or Selma chalk to provide equivalent values to agricultural limestone.

Fertilizer

Apply fertilizer according to soil test results. If a soil test is not available, apply 8-24-24 fertilizer at a rate of 400 lbs/acre (approximately 9 lbs/1000 ft²).

When vegetation has emerged to a stand and is growing, 30 to 40 lbs/acre (approximately 0.8 lbs/1000 ft²) of additional nitrogen fertilizer should be applied.

Note: Fertilizer can be blended to meet exact fertilizer recommendations. Take soil test recommendations to local fertilizer dealer for bulk fertilizer blends. This may be more economical than bagged fertilizer.

Application of Soil Amendments

Incorporate lime and fertilizer into the top 6" of soil during seedbed preparation.

Seedbed Preparation

Good seedbed preparation is essential to successful plant establishment. A good seedbed is well pulverized, loose, and smooth. If soils become compacted during grading, loosen them to a depth of 6" to 8" using a ripper or chisel plow.

If rainfall has caused the surface to become sealed or crusted, loosen it just prior to seeding by disking, raking, harrowing, or other suitable methods. When hydroseeding methods are used, the surface should be left with a more irregular surface of clods.

Planting Methods

Seeding

Evenly apply seed using a cyclone seeder (broadcast), drill seeder, cultipacker seeder, or hydroseeder. Broadcast seeding and hydroseeding are appropriate for steep slopes where equipment cannot operate safely. Small grains should be planted no more than 1" deep, and grasses and legumes no more than ½" deep. Seed that are broadcast must be covered by raking or chain dragging, and then lightly firmed with a roller or cultipacker.

Hydroseeding

Surface roughening is particularly important when hydroseeding, as a roughened slope will provide some natural coverage for lime, fertilizer, and seed. The surface should not be compacted or smooth. Fine seedbed preparation is not necessary for hydroseeding operations; large clods, stones, and irregularities provide cavities in which seeds can lodge.

Mix seed, inoculant if required, and a seed carrier with water and apply as slurry uniformly over the area to be treated. The seed carrier should be a cellulose fiber, natural wood fiber or other approved fiber mulch material which is dyed an appropriate color to facilitate uniform application of seed. Use the correct legume inoculant at 4 times the recommended rate when adding inoculant to hydroseeder slurry. The mixture should be applied within one hour after mixing to reduce damage to seed.

Fertilizer should not be mixed with the seed-inoculant mixture because fertilizer salts may damage seed and reduce germination and seedling vigor. Fertilizer may be applied with a hydroseeder as a separate operation after seedlings are established.

Mulching

The use of appropriate mulch provides instant cover and helps ensure establishment of vegetative cover under normal conditions and is essential to seeding success under harsh site conditions (see the Mulching practice for guidance). Harsh site conditions include the following: slopes steeper than 3:1 and adverse soils (soils that are shallow to rock, rocky, or high in clay or sand). Areas with concentrated flow should be treated differently and require a practice appropriate for channel flow. (Refer to Chapter 5 Runoff Conveyance for guidance).

Tree Planting On Disturbed Areas (TP)



Practice Description

Tree planting on disturbed areas is planting trees on construction sites or other disturbed areas to stabilize the site. The practice reduces erosion and minimizes the maintenance requirements after a site is stabilized. The practice is applicable to those areas where tree cover is desired and is compatible with the planned use of the area, particularly on steep slopes and adjacent to streams. Tree planting is usually used with other cover practices such as permanent seeding or sodding.

Planning Considerations

Control grasses and legumes when planted in combination with trees to reduce competition for moisture, nutrients, and sunlight.

Select trees that are adapted to soil and climate.

Avoid planting species which are invasive or may become a nuisance.

Avoid trees that have undesirable characteristics.

Select trees that will improve aesthetics and provide food and cover for wildlife.

Consider using tree tubes as they will help protect the trees from wildlife damage, mowers, weed-eaters, etc. and increase growth of the seedling during the first year.

Tree mats around young seedlings can be helpful in reducing competition from weeds and grasses during the critical first year of growth.

Design Criteria

Planting Bare-rooted Tree Seedlings

Site Preparation

Compacted soil should be ripped or chiseled on the contour to permit adequate root development and proper tree growth. Debris should be removed from the site to facilitate tree planting.

Planting Methods

Tree seedlings may be planted by hand or machine. Any tool or piece of equipment that gives satisfactory results may be used. Dibble bars, mattocks, augers, post-hole diggers and shovels may be used to plant trees by hand. Wildland tree planting machines should be used on rough areas or areas with clayey or compacted soils. Old field tree planters should be limited to areas with sandy soils that are not compacted. Plantings on sloping land should be done on the contour.

When

Bare-root seedlings should be planted from December 1 to March 15. Planting should be done when the soil is neither too dry nor too wet. Planting should be avoided during freezing weather and when the ground is frozen.

Planting Rate

To control erosion, pines should be planted at a rate of 600 to 700 trees per acre and hardwoods should be planted at a rate of 300 to 500 trees per acre. Severely eroding areas should be planted at the rate of 600 to 900 trees per acre for both pine and hardwood species.

Depth of Planting

Trees should be planted deeper than they grew in the nursery. Plant small stock 1" deeper and medium to large stock ½" deeper. On most soils, longleaf pine seedlings should be planted ¼" deeper than they grew in the nursery (note: this is not true for planting depth of container grown longleaf seedlings – see Site Preparation in next section for container grown seedlings).

Condition of Roots

Roots should be planted straight down and not twisted, balled, nor U-shaped. Soil should be packed firmly around the planted seedlings. No air pockets should be left in either machine furrows or holes made by planting tools.

Care of Seedlings

The roots of seedlings must be kept moist and cool always. After lifting, seedlings should not be exposed to sun, wind, heating, drying, or freezing before they are planted. Baled seedlings may be kept up to 3 weeks if they are properly stacked, watered, and kept in a cool place. When planting is delayed longer than 3 weeks, the roots of seedlings should be covered with moist soil (heeled-in) or the seedlings should be put in cold storage.

During planting, the roots of seedlings must be kept moist and only one seedling should be planted at a time. At the end of each day, loose seedlings should be either repacked in wet moss or heeled-in.

Mulching

Mulching may be necessary on sloping land to reduce erosion. Mulch with wood chips, bark, pine needles, peanut hulls etc. should be done to a depth of no more than 3". Mulch should not be placed against the trunk of the tree.

Planting Balled and Burlapped and Container-Grown Trees

Site Preparation

The planting hole should be dug deep and wide enough to allow proper placement of the root ball. The final level of the root ball's top should be level with the ground surface (See Figure TP-1). For container grown longleaf seedlings, the planting depth should be slightly higher than the depth grown in the nursery.

As the hole is dug the topsoil should be kept separate from the subsoil. If possible, the subsoil should be replaced with topsoil. If topsoil is unavailable the subsoil can be improved by mixing in $\frac{1}{3}$ volume of peat moss or well-rotted manure.

Heavy or poorly drained soils are not good growth media for trees. When it is necessary to transplant trees into such soils, extra care should be taken.

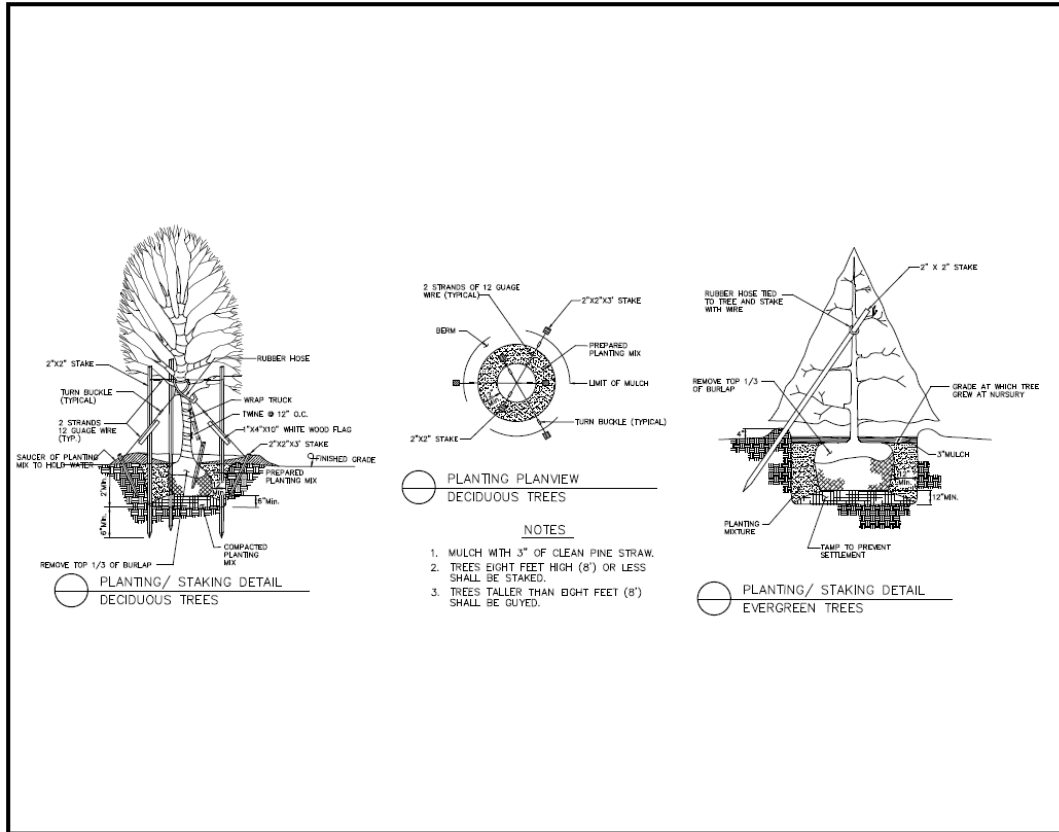

Figure TP-1 Tree Planting Diagram

Tree Preparation

The proper digging of a tree includes the conservation of as much of the root system as possible, particularly the fine roots. Soil adhering to the roots should be damp when the tree is dug and kept moist until planting. The soil ball should be 12" in diameter for each inch of diameter of the trunk. The tree should be carefully excavated, and the soil ball wrapped in burlap and tied with rope. Use of a mechanical tree spade is also acceptable.

Any trees that are to be transported for a long distance should have the branches bound with a soft rope to prevent damage.

Planting the Tree

Depth of planting must be close to the original depth. The tree may be set just a few inches higher than in its former location, especially if soil is poorly drained. Do not set the tree lower than before. Soil to be placed around the root ball should be moist but not wet.

Set the tree in the hole and if the tree is balled and burlapped remove the rope which holds the burlap. Loosen the burlap and remove completely if practical. Do not break the soil of the root ball. Fill the hole with soil halfway and add water to settle the soil and eliminate air pockets. When the water has drained off, fill the hole the remainder of the way. Use extra soil to form a shallow basin around the tree. This will help retain water.

Newly planted trees may need artificial support to prevent excessive swaying. Stakes and guy wires may be used (see Figure TP-1). Guying should be loose enough to allow some movement of the tree.

Mulching

Mulching may be necessary on sloping land to reduce erosion and should be used around balled and burlapped trees and container grown trees to help conserve soil moisture and reduce competition from weeds and grass. Apply mulch using wood chips, bark, pine needles, peanut hulls etc. to a depth of no more than 3". Mulch should not be placed against the trunk of the tree.

This Page Intentionally Left Blank

Check Dam (CD)



Practice Description

A check dam (also referred to as a “ditch check”) is a barrier constructed across a conveyance to impound water for the purpose of velocity reduction by flattening the flow gradient and reducing shear stress within the channel. This practice applies in small open channels and drainageways, including temporary and permanent swales.

Check dams are not to be used in a live stream. Situations of use include areas in need of protection during establishment of grass and areas that cannot receive a temporary or permanent non-erodible lining for an extended period.

Planning Considerations

Check dams are used in concentrated flow areas to provide temporary channel stabilization with minimal sediment retention during rainfall runoff periods on construction sites. Channel erosion is reduced because check dams flatten the gradient of the flow channel and slow the velocity of channel flow. Check dams do not reduce turbidity of runoff. Check dams can be constructed of rock, wattles (sometimes referred to as tubes or rolls), sandbags, or other materials that may be acceptable to the design professional. Unless installed correctly, check dams will not capture a significant amount of sediment. When installed correctly, most check dams can capture the coarser grained material, which can be significant for sandy

soils. Sediment capture increases as velocity in the channel decreases by creating impoundments with the check dams. This impoundment pool creates the flattening of the gradient, greatly reducing channel erosion.

Water flowing over a check dam creates turbulent erosive forces (super critical flow) that must be addressed to prevent erosion downstream of the check dam. Inevitably, water will likely flow under check dams due to limitation with ground contact. Therefore, it is of utmost importance to ensure the performance of the check dam that erosion and scour under the check dam be minimized. This is best achieved using an underlay such as an 8-oz. nonwoven filter fabric. If the underlay is extended downstream, it will also protect the channel from super critical flows from water flowing over and under the dam.

Check dams should be planned to be compatible with the other features such as streets, walkways, trails, sediment basins and rights-of-way or property lines. Check dams are installed with the center overflow area lower in elevation than the ends to ensure flow goes over the check dam and not around. Check dams are normally constructed in series and the dams should be located at a normal interval from other grade controls such as culverts or sediment basins.

Check dams are generally used as a temporary BMP that is removed following construction to allow for final long-term stabilization of the channel. Provisions should be made to establish permanent channel linings as early as possible.

Check dams can also be used for other purposes such as the capture of sediment upstream of other practices or flocculent dosing upstream of a sediment basin.

Extensive research has been conducted by The Auburn University Stormwater Research Facility. The research recommendations are incorporated in the following planning considerations:

Rock Check Dams

Many check dams are constructed of rock. Rock may not be acceptable in some installations and alternative types of check dams need to be considered. Rock check dams (Figures CD-1 and CD-2) are usually installed with mechanical equipment, but hand labor is likely needed to complete most installations to the quality needed. The availability and cost of commercially produced rock should be considered. The use of rock should be considered carefully in areas to be mowed. Some rock may be washed downstream and should be removed before each mowing operation. The use of geotextile can be used on the upstream face of the rock check dam to increase the sediment trapping efficiency of the rock check dam. Measures must be taken to prevent undermining of the check dam and erosion below the check dam. A non-woven geotextile underlayment should be used to prevent this from happening. The geotextile meeting AASHTO M 288 requirement for separation Class II (minimum 8-oz. fabric) should extend approximately 3 ft. upstream and downstream, and pinned securely with the upstream edge buried.

Measures to prevent downstream erosion associated with a rock check dam include placing larger rock on the downstream face of a rock dam and providing erosion protection material just downstream of the dam.

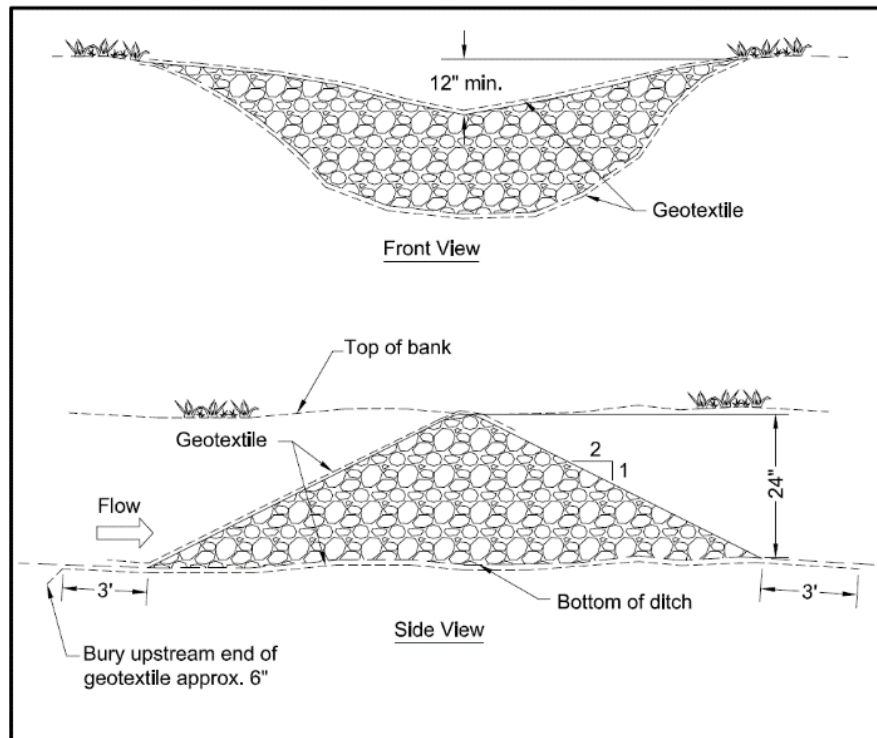

Figure CD-1 Profile and Cross-Section of Typical Rock Check Dams

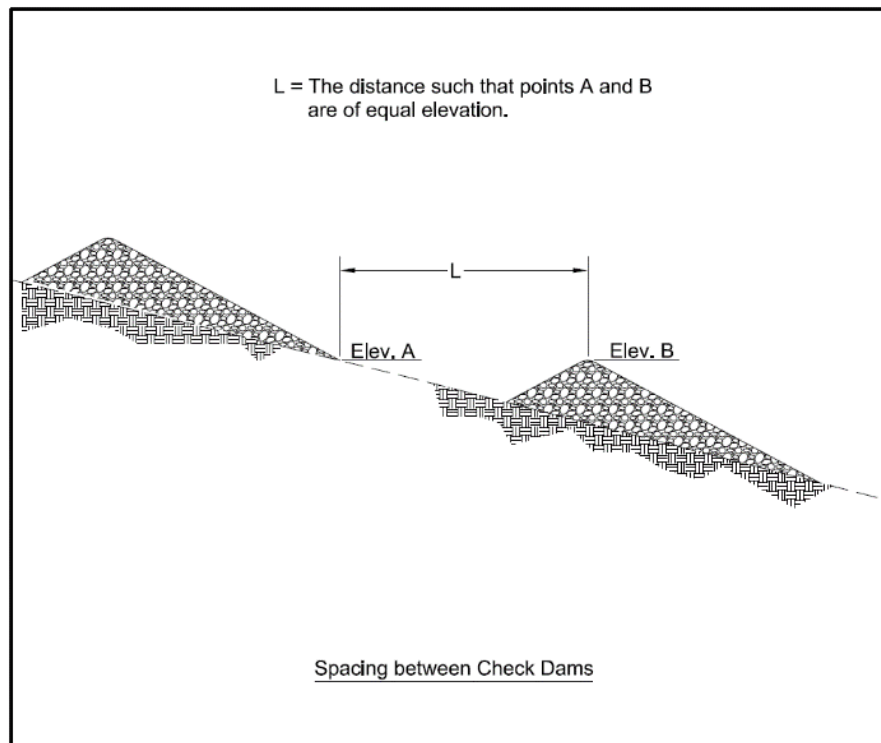

Figure CD-2 Profile of Typical Rock Check Dams

Wattle Check Dams

Wattles have been found to be best installed without trenching and on top of stapled geotextile underlayment that extends a minimum 3 ft. up and downstream from the wattle. Wattles must be properly stapled with sod staples on approximately 6-inch centers on each side of the wattle to prevent flotation and staked over the top using non-destructive tee-pee type staking. Wattles that provide less “flow through” create more ponding of water that increases the trapping of sediment (see Figures CD-3 and CD-4).

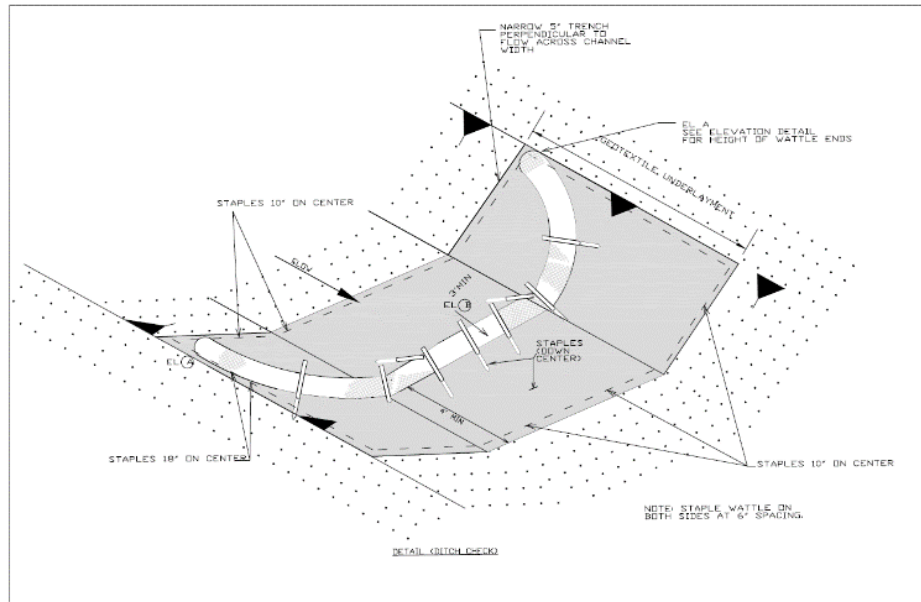

Figure CD-3 Wattle Check Dam (ditch check)



Figure CD-4 Wattle Check Dam (ditch check)
(Photo courtesy of Auburn University Stormwater Research Facility)

Silt Fence Check Dam

When properly designed and installed, typical silt fence materials can be utilized to construct a check dam. Geotextile underlayment should be used, and the fence notched as needed to ensure the maximum depth of flow is no greater than the depth of the channel. Figures CD-5 and CD-6 show the recommended details.

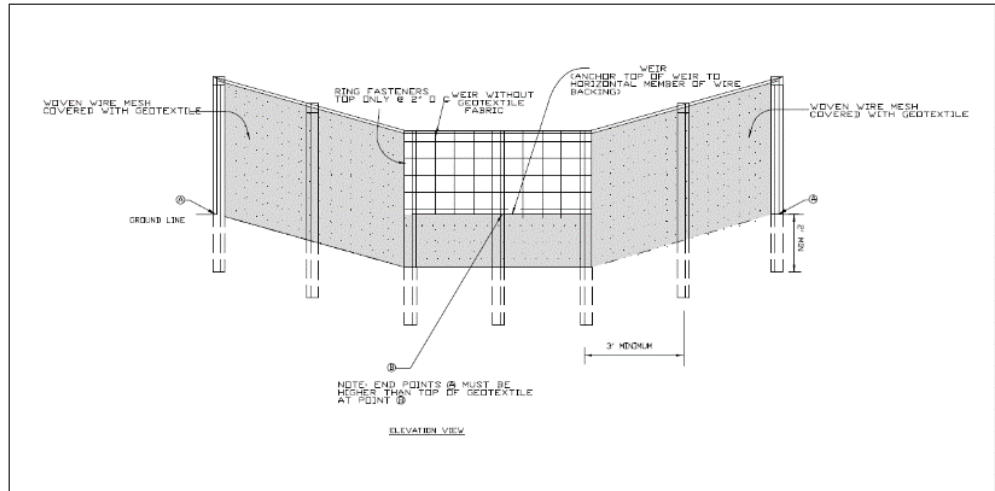

Figure CD-5 Silt Fence Check Dam Cross-Section

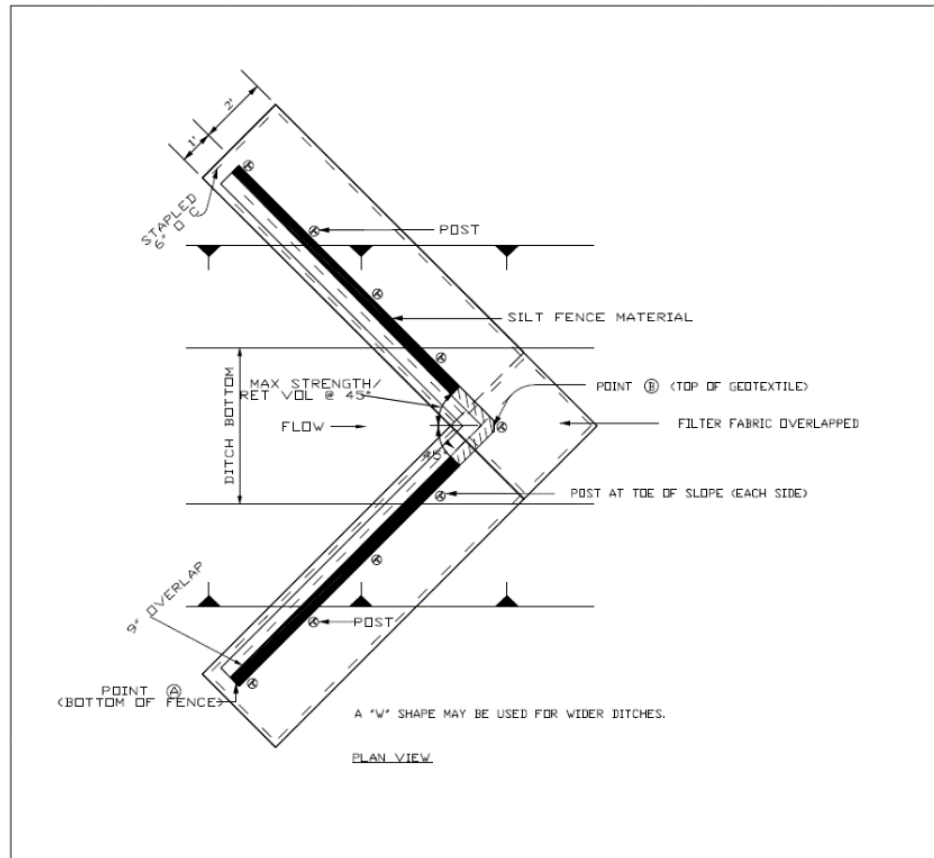

Figure CD-6 Silt Fence Check Dam Plan View



Figure CD-7 Silt Fence Check Dam
(Photo courtesy of Auburn University SWRC)

Sandbag Check Dam

Sandbags have also been proven to be effective as check dams but only when the bags are properly oriented (See Figures CD-8 and CD-9). A geotextile underlayment that extends approximately 3 ft. upstream and downstream should also be used in earth channel situations to prevent undermining and scour.

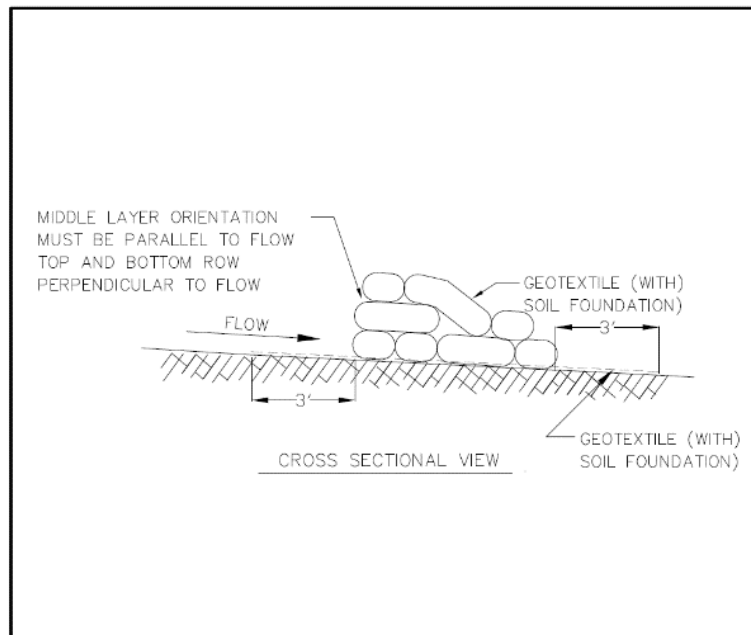

Figure CD-8 Sandbag Check Dam Cross-Section

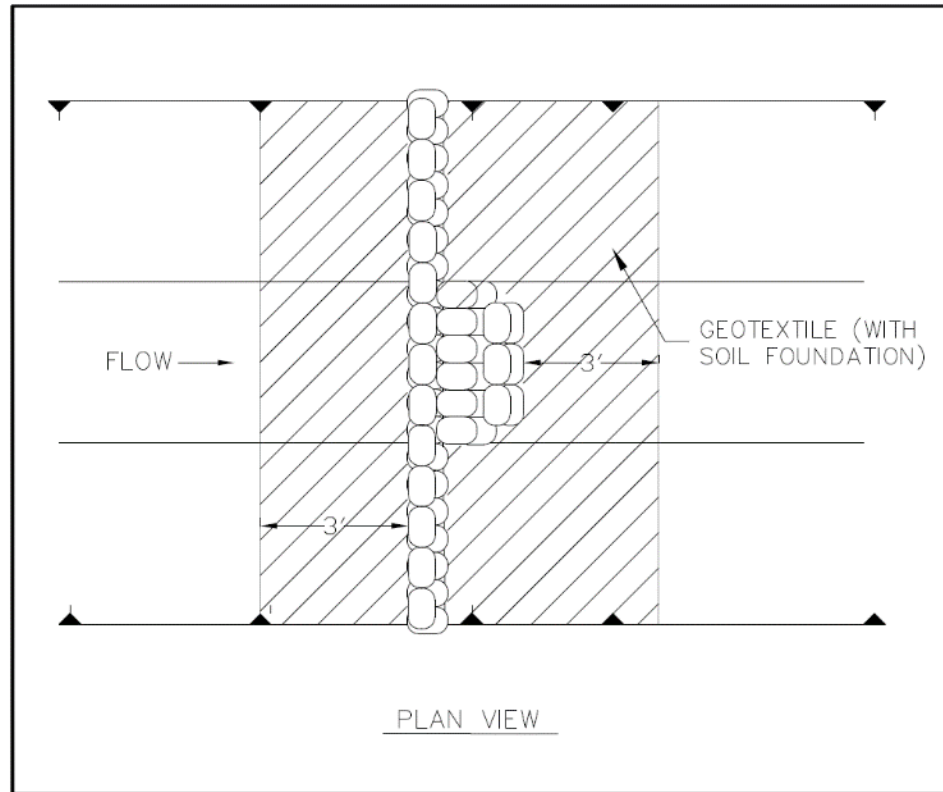

Figure CD-9 Sandbag Check Dam Plan View

Design Criteria

Formal design is not required. The following factors should be considered when designing check dams.

Drainage Area

Generally, one acre or less.

Maximum Height

Check dam height is a function of channel geometry. Most check dams are 3 feet or less in height.

Depth of Flow

Depth of flow over a check dam is a function of the cross-section and porosity of the check dam. Generally, flows over a check dam are less than 1 foot.

The center of the dam should be constructed lower than the ends. The elevation of the center of the dam should be lower than the ends by the depth of design flow.

Side Slopes

2:1 or flatter (rock check dam).

Spacing

The elevation of the toe of the upstream dam should be at or below the elevation of crest of the downstream dam (Figure CD-2).

For example, if the channel is 3% grade, and the check dam height is 2 feet, The check dam spacing should be 67 feet:

$$\text{Spacing (ft)} = \text{dam height (ft)} / \text{channel grade}$$

$$\text{Spacing} = 2 \text{ ft} / 0.03 = 67 \text{ feet}$$

Geotextile

Generally, the non-woven geotextile should meet the requirements found in AASHTO M 288 Class II used for separation.

Diversion (DV)



Practice Description

A diversion is a watercourse constructed on a designed grade, across a slope, and consisting of an excavated channel, a compacted ridge, or a combination of both.

This practice applies to sites where stormwater runoff can be redirected to permanently protect structures or areas downslope from erosion, sediment, and excessive wetness or localized flooding. Diversions may be used to temporarily divert stormwater runoff to protect disturbed areas and slopes or to retain sediment on-site during construction.

Planning Considerations

Diversions are designed to intercept and carry excess water to a stable outlet.

Diversions can be useful tools for managing surface water flows and preventing soil erosion. On moderately sloping areas, they may be placed at intervals to trap and divert sheet flow before it has a chance to concentrate and cause rill and gully erosion.

Most diversions are constructed by excavating a channel and using the excavated material to construct a ridge on the downslope side of the channel. Right-of-way diversions and temporary diversions are sometimes constructed by making a ridge, often called a berm, from fill material.

Perimeter protection is sometimes used to describe both permanent and temporary diversions used at either the upslope or downslope side of a construction area.

Right-of-way diversions, sometimes referred to as water bars, are used to shorten the flow length on a sloping right-of-way and reduce the erosion potential of the stormwater runoff.

Diversions may be placed at the top of cut or fill slopes to keep runoff from upgradient drainage areas off the slope. The following picture illustrates the placement of a diversion near the top of the slope. Diversions are sometimes built at the base of steeper slopes to protect flatter developed areas which cannot withstand runoff water from outside areas. Also, they can be used to protect structures, parking lots, adjacent properties, and other special areas from flooding.



Figure DV-1 Diversion near the top of a slope

Diversions are preferable to other types of man-made stormwater conveyance systems because they more closely simulate natural flow patterns and characteristics. Flow velocities are generally kept to a minimum. When properly coordinated into the landscape design of a site, diversions can be visually pleasing as well as functional.

As with any earthen structure, it is very important to establish adequate vegetation as soon as possible after installation. It is usually important to stabilize the drainage area above the diversion so that sediment will not enter and accumulate in the diversion channel.

Design Criteria

Location

Diversion location should be determined by considering outlet conditions, topography, land use, soil type, length of slope, seepage (where seepage is a problem) and the development layout. Outlets must be stable after the diversion empties stormwater flow into it; therefore, care should be exercised in selecting the location of the diversion and its outlet.

Slope (Grade)

The bed slope of the diversion should be selected to meet velocity, capacity, and lining requirements for the site. Variable grades may be needed to obtain more uniform cross-sections and improve alignment. During the design process, the slope may need to be modified to meet stability and capacity requirements.

Capacity

The diversion channel must have a minimum capacity to carry the runoff expected from a storm frequency meeting the requirements of Table DV-1 with a freeboard of at least 0.3 foot (Figure DV-2).

The storm frequency should be used to determine the required channel capacity, Q (peak rate of runoff). The peak rate of runoff should be determined using the Natural Resources Conservation Service runoff curve number (RCN) method or other equivalent methods.

Table DV-1 Design Frequency

Diversion Type	Typical Area of Protection	24-Hour Design Storm Frequency
Temporary	Construction Areas	2-year
	Building Sites	5-year
Permanent	Agricultural Land	10-year
	Mined Reclamation Area	10-year
	Recreation Areas	10-year
	Isolated Buildings	25-year
	Urban areas, Residential, School, Industrial Areas, etc.	50-year

Diversions designed to protect homes, schools, industrial buildings, roads, parking lots, and comparable high-risk areas, and those designed to function in connection with other structures, should have sufficient capacity to carry peak runoff expected from a storm frequency consistent with the hazard involved.

Velocities

Diversions should be planned and designed for the conditions of the construction site. If the diversion is grass or earth-lined, the acceptable velocity to be expected will be determined by the allowable soil effective stress and the properties of the vegetation.

Cross-Section Shape

The land slope where the diversion is to be constructed must be taken into consideration when choosing a channel cross-section. On steeper terrain, narrow and deep channels may be required to reduce earth-moving quantities. However, if the diversion is to be vegetated or unlined, there may be a limit to how steep and deep it can be and still meet allowable effective stress criteria for stability. Broad, shallow channels usually are more applicable on gentler terrain. The diversion channel may be parabolic, trapezoidal, or V-shaped as shown in Figure DV-2.

Ridge Design

The supporting ridge cross section should meet the configuration and requirements of Figure DV-2.

The side slopes should be no steeper than 2:1. Side slopes should be flatter, 5:1 to 10:1, when the diversion is to be permanent with mowing and other maintenance activities performed on or around it.

The width of the ridge at the design water elevation should be a minimum of 4 feet.

The minimum freeboard should be 0.3 foot.

The design should include a 10% settlement factor.

Soils Investigation

The soil textures encountered along the diversion are needed to determine the allowable soil effective stress for stability assessment of bare soil and vegetated channels.

Outlet

Diversions should have adequate outlets which will convey concentrated runoff without erosion. Acceptable outlets include practices such as Grassed Swale, Lined Swale, Drop Structure, Riprap-Lined Swale, Sediment Basin, and Stormwater Detention Basins.

Stabilization

Unless otherwise stabilized, the ridge and channel should be seeded within 13 days of installation in accordance with the applicable seeding practice, Permanent Seeding or Temporary Seeding.

Disturbed areas draining into the diversion should be seeded and mulched prior to or at the time the diversion is constructed in accordance with the Permanent Seeding or Temporary Seeding (whichever is applicable) practices.

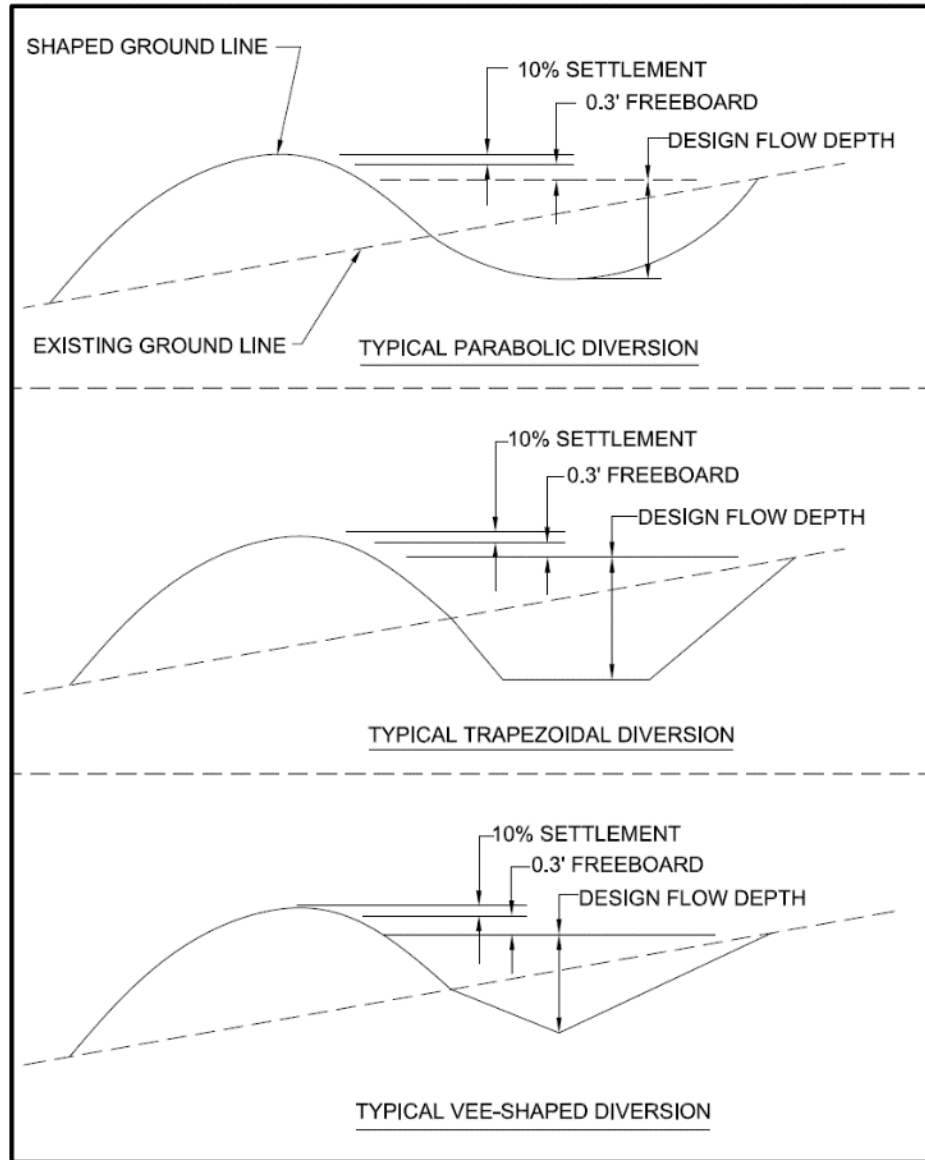

Figure DV-2 Typical Diversions Detail

Diversion Design

Steps in Designing a Diversion

1. Plan the location and type of diversion that minimizes negative impacts.
2. Select design points along the diversion where grades change or drainage areas and type of lining change significantly.
3. Determine the watershed area for the points in step 2 and for the outlet.
4. Find the peak runoff produced by the design storm at each design point identified in step 2.
5. Determine the slope of each reach of the diversion.
6. For the type of diversion to be constructed, select the appropriate channel cross section and the type of channel lining to be used, for example, bare soil, vegetation, rigid lining, or some combination.
7. Design the channel cross section for adequate capacity, typically based on the densest vegetation expected.
8. Check the design for stability by computing effective stress based on the sparsest vegetation expected. Repeating stability design computations may be necessary to complete the design if the stability check shows an inadequate design.
9. Add appurtenant structures, such as reinforced centers, as needed to allow for prolonged flows.

References and Tools for Diversion Design

General design guidance can be found in the USDA-NRCS Part 650, Engineering Field Handbook, Chapter 9, Diversion.

<https://directives.sc.egov.usda.gov/OpenNonWebContent.aspx?content=46275.wba>

Design tables can be found in the appendix of USDA-NRCS Part 650, Engineering Field Handbook, Chapter 7, Grassed Waterways.

<https://directives.sc.egov.usda.gov/OpenNonWebContent.aspx?content=46771.wba>

Software for the design of a diversion can be found in the USDA-NRCS Engineering Field Tools (EFT). This can be downloaded at:

<https://www.nrcs.usda.gov/wps/portal/nrcs/detailfull/national/ndcsmc/?cid=stelprd b1042198>

Drop Structure (DS)



Practice Description

A drop structure is an erosion control measure created by construction of a barrier across a drainageway with a pipe drop structure, or by installing a permanent manufactured product down a slope. The purpose of a drop structure is to convey concentrated flow storm runoff from the top to the bottom of a slope or to lower water from a grassed swale into an open channel such as an intermittent or perennial stream. This practice applies where other erosion control measures are insufficient to prevent excessive erosion and off-site sedimentation.

Planning Considerations

This practice applies to sites where earth and vegetation cannot safely handle water at permissible velocities, where excessive grades or overfall conditions are encountered, or where water is to be structurally lowered from one elevation to another. These structures should be planned and installed as a part of an overall surface water disposal system. This practice does not apply to storm sewers, concrete overfall structures, in channel grade control structures, or road culverts.

Design Criteria

Design and specifications shall be prepared for each structure on an individual job basis depending on its purpose and site conditions.

Capacity

The minimum design capacity for pipe structures shall be as required to pass the peak runoff expected from a 2-year frequency, 24-hour duration storm. Peak rates of runoff values used to determine the capacity requirements should be calculated using accepted engineering methods. Some accepted methods are:

- Natural Resources Conservation Service, National Engineering Handbook Series, Part 650, Engineering Field Handbook, Chapter 2, Estimating Runoff.
- Natural Resources Conservation Service, formerly Soil Conservation Service, Technical Release 55, Urban Hydrology for Small Watersheds.
- Other comparable methods.

Runoff computation will be based upon the most severe soil and cover conditions that will exist in the area draining into the pipe structures during the planned life of the structure.

All pipe structures should be designed as island type structures with an auxiliary spillway to safely pass storms larger than the structure design storm. The minimum total capacity of the principal and emergency spillways shall be that required to handle the 25-year 24-hour duration storm, or the peak rate of flow from the contributing structure, whichever is greater. The emergency spillway should be located at the end of the embankment on natural ground. It should not be placed over the earthfill embankment.

General

The planning and design of antivortex devices, trash racks and anti-seep collars should be in accordance with the requirements for principal spillway pipe design in the Sediment Basin practice. In lieu of anti-seep collars, a filter diaphragm with a filter compatible outlet is the best alternative (See NRCS National Engineering Handbook Chapter 45 – Filter Diaphragms for design procedures). Outlet protection for pipes should be designed according to the Outlet Protection practice.

Straight pipe structures should be built in accordance with Figure DS-1.

Pipe drop structures should be built in accordance with Figure DS-2.

The crest elevation for the auxiliary spillway shall be set at the minimum level necessary to ensure full pipe flow of the principal spillway. The top of the settled embankment shall be based on 1 foot of freeboard above the design flow depth in the emergency spillway.

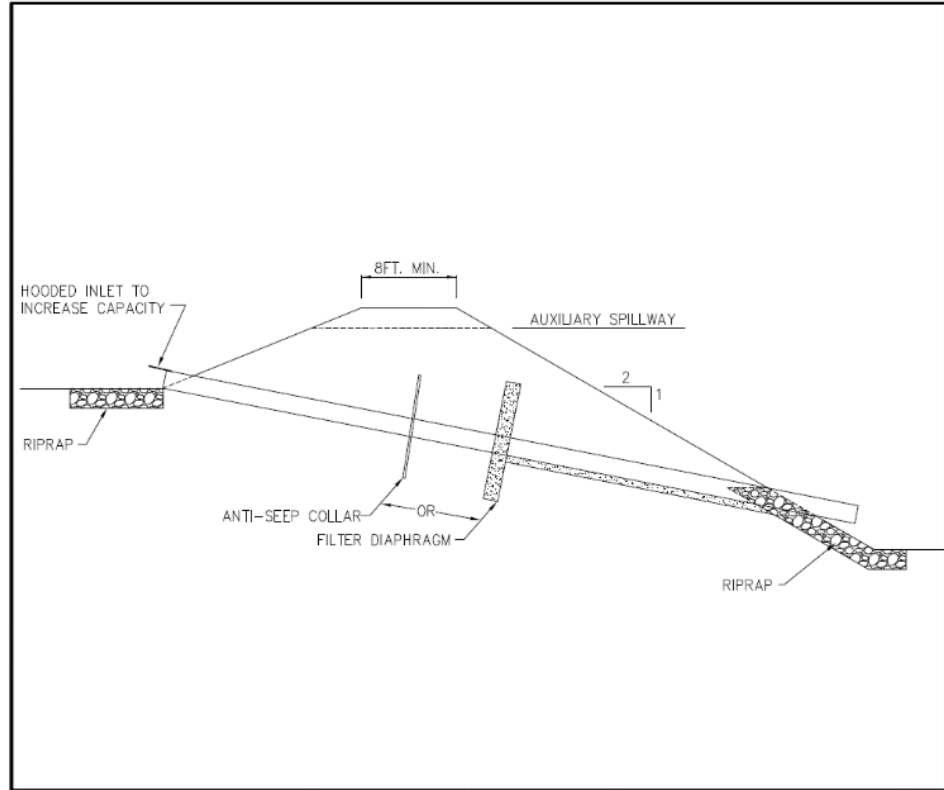

Figure DS-1 Straight Pipe Structure

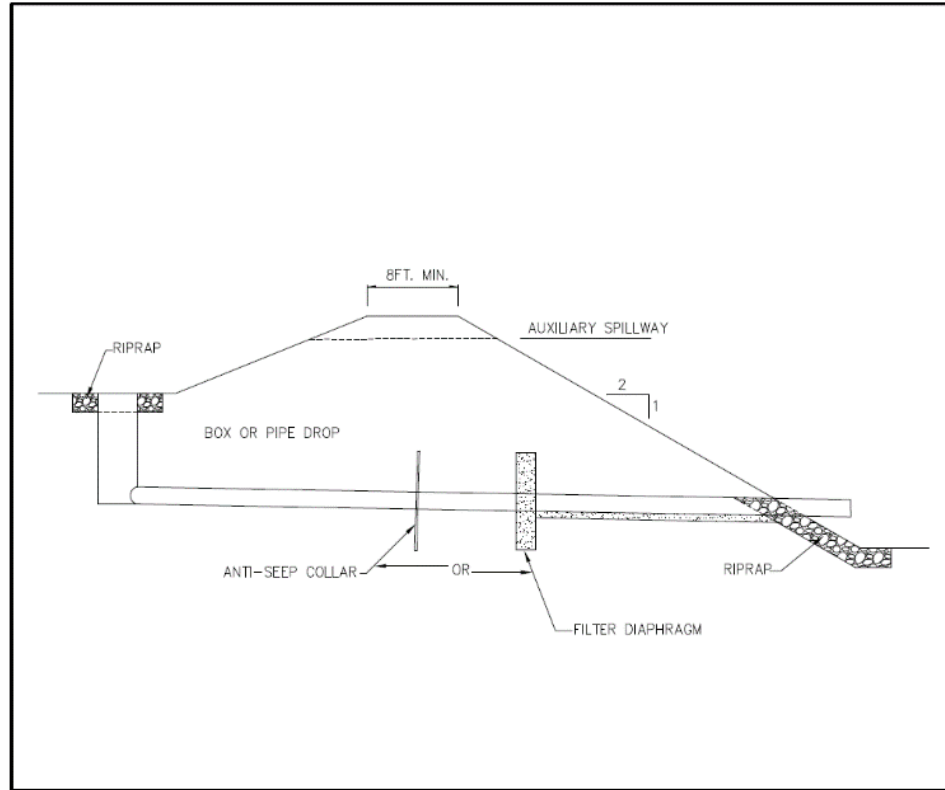

Figure DS-2 Pipe Drop Structure

Grass Swale (GS)



Practice Description

A grass swale is a natural or constructed channel with established permanent grasses used for water quality or to convey stormwater runoff which does not rely on the permeability of the soil as a pollutant removal mechanism. This practice applies to sites where concentrated runoff will cause erosion damage, a vegetative lining provides sufficient stability for the channel as designed, and space is available for a relatively large cross section. Typical situations where concentrated flow areas are addressed with a grass swale include roadside ditches, channels at property boundaries, outlets for diversions and other concentrated flow areas subject to channel erosion. Grassed swales are generally considered permanent structures but may be used as a temporary measure.

Planning Considerations

Grass swales should be carefully built to the design cross section, shape, and dimensions. Swales are hydraulic structures and as such depend upon the hydraulic parameters to function satisfactorily. Vegetated swales should be well established before large flows are permitted in the channel.

The design of a channel cross section and lining is based primarily upon the capacity and stability requirements for the channel. This practice covers grassed swales with low velocity flows (generally less than 5 ft/sec). Where high velocities are anticipated lined swales should be used (see Lined Swale practice or Riprap-lined Swale practice). Lined swales should also be used where there is continuous flow in the swale, which would prevent establishment of vegetation within the flow area.

Besides the primary design considerations of capacity and stability, a number of other important factors should be taken into account when selecting a cross section (Figure GS-1). These factors include land availability, compatibility with land use and surrounding environment, safety, maintenance requirements outlet conditions, etc.

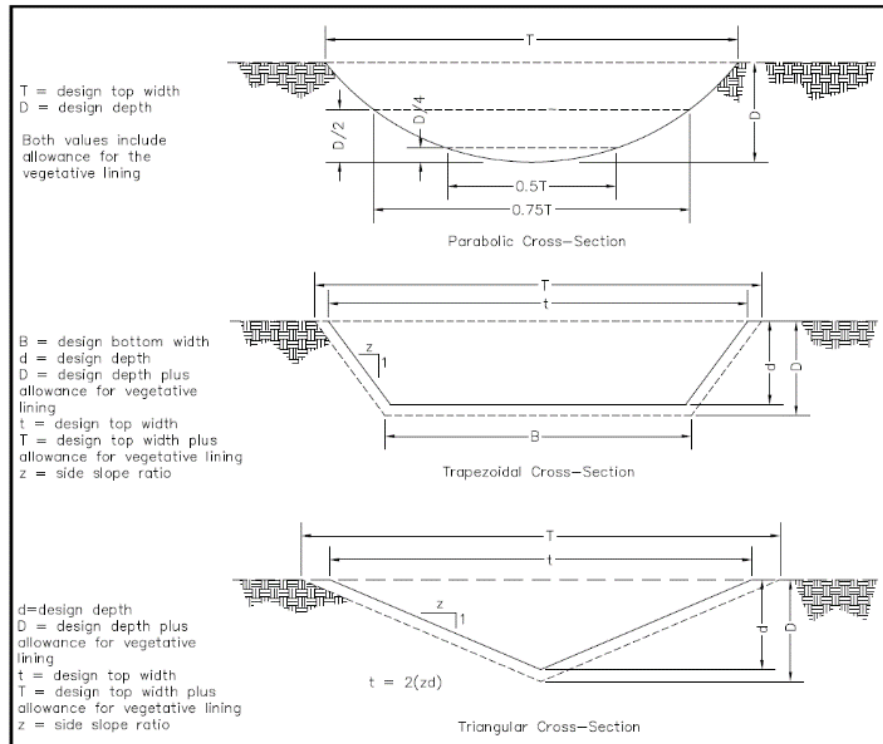

Figure GS-1 Typical Grass Swale Cross section

Triangular Shaped Ditches

Triangular shaped ditches are generally used where the quantity of water to be handled is relatively small, such as along roadsides. A triangular grass swale will suffice where velocities in the ditch are low.

Parabolic Channels

Parabolic channels are the most common and generally the most satisfactory. These channels are often used where the quantity of water to be handled is larger and where space is available for a wide, shallow channel with low velocity flow.

Trapezoidal Channels

Trapezoidal channels are often used where the quantity of water to be carried is large and conditions require that it be carried at a relatively high velocity. Trapezoidal ditches lined with concrete, riprap, or others similar materials are considered lined swales or riprap lined swales. In some cases, erosion control blankets (see Erosion Control Blanket practice) and high-end hydraulic mulch (see Mulching practice) can be used to establish vegetation.

Other Considerations

Outlet conditions for all channels should be considered. Appropriate measures must be taken to dissipate the energy of the flow to prevent scour at the outlet of the swale.

Grass swales should be protected from erosion by concentrated flows. The methods of protecting grass swales would include, but not be limited to the following:

- Vegetation.
- Biodegradable linings and vegetation.

The type and intensity of the protective linings will determine the design of the grass swale.

If stability cannot be achieved for vegetated swales or vegetation with biodegradable linings, then other linings should be used (see Lined Swale or Riprap-lined Swale practice).

The time of the year should be considered when planning grass swales. Grass swales that are seeded to establish vegetation should not be planned for construction during late fall, winter, or early spring. Grass swales constructed during mid-summer to early fall may need temporary seeding followed by permanent seeding at the recommended times. The vegetation species should be recommended for the area of the state that it is planned.

Design Criteria

Capacity

Grass swales shall be designed to convey the peak rate of runoff as shown in Table GS-1. Adjustments should be made for release rates from structures and other drainage facilities. Grass swales shall also be designed to comply with local stormwater ordinances. Grass swales should be designed for greater capacity whenever there is danger of flooding or out of bank flow cannot be tolerated.

Table GS-1 Design Frequency for Grassed Swale

Grass Swale Type	Typical Area of Protection	24 Hour Design Storm Frequency
Temporary Swale	Construction Areas	2-year
	Building Sites	5-year
Permanent Swale	Agricultural Land	10-year
	Reclaimed Mined Land	10-year
	Isolated Buildings	10-year
	Urban areas, Residential, School, Industrial Areas, Recreation Areas, etc.	10-year

Peak rates of runoff values used to determine the capacity requirements should be calculated using accepted engineering methods. Some accepted methods are:

- Natural Resources Conservation Service, National Engineering Handbook Series, Part 650, Engineering Field Handbook, Chapter 2, Estimating Runoff.
- Natural Resources Conservation Service, formerly Soil Conservation Service, Technical Release 55, Urban Hydrology for Small Watersheds.
- Other comparable methods.

Grade of Grass Swale

After selecting a location for the grassed swale that will minimize the impacts to the site and maximize the intended use, the grade in the grass swales should be determined. The grade in feet per 100 feet of length can be determined from a topographic map of the site or from a detailed survey of the planned grassed swale location.

Drainage

Polyethylene drainage tubing, tile or other suitable subsurface drainage measures shall be provided for sites having high water tables or seepage problems.

Freeboard

The minimum freeboard is 0.25 feet in depth. Freeboard is not required on grass swales with less than 1% slope and where out-of-bank flow will not be damaging and can be tolerated in the normal operation at the site.

Steps in Designing a Grass Swale

1. Plan the optimum location of the swale centerline.
2. Select design points along the swale where grades change or drainage areas and type of lining change significantly.
3. Determine the watershed area for the points in step 2 and for the outlet.
4. Find the peak runoff produced by the design storm at each design point identified in step 2.
5. Determine the slope of each reach of the swale.
6. Select the appropriate channel cross section and the type of grass to line the channel.
7. Determine the allowable effective stress based on an evaluation of the soil material.
8. Determine the vegetal cover factor associated with sparsest and shortest vegetation expected (typically winter vegetation) and the densest and longest vegetation (typically summer vegetation).

9. Determine allowable stress on the vegetation based on the sparsest and shortest vegetation and the flow retardance offered by the densest and longest vegetation.
10. Use design aids or equations to size channel for stability by computing effective stress based on sparsest and shortest vegetation. Check that the allowable stress is less than effective stress. Repeating stability design computations maybe necessary to complete the design if the stability check shows an inadequate design.
11. Use design aids or equations to determine depth required to obtain adequate capacity for the densest and longest vegetation.
12. Add freeboard as needed.
13. Add appurtenant structures as needed to allow for prolonged flows, improve water quality, and protect outlets.

References and Tools for Grass Swale Design

General design guidance can be found in USDA-NRCS Part 650, Engineering Field Handbook, Chapter 7, Grassed Waterways.

<https://directives.sc.egov.usda.gov/OpenNonWebContent.aspx?content=46771.wba>

Software for the design of a grass swales (grassed waterways) can be found in the USDA-NRCS Engineering Field Tools (EFT). This can be downloaded at:

<https://www.nrcs.usda.gov/wps/portal/nrcs/detailfull/national/ndcsmc/?cid=stelprdb1042198>

This Page Intentionally Left Blank

Lined Swale (LS)



Practice Description

A lined swale is a constructed channel with a permanent lining designed to carry concentrated runoff without channel erosion to a stable outlet. This practice applies where grass swales are unsuitable because of conditions such as steep channel grades, prolonged flow areas, soils that are too erodible or not suitable to support vegetation or insufficient space and where riprap-lined swales are not desired.

The material that provides the permanent lining may be concrete, manufactured concrete products, tied concrete block mats, or turf reinforcement mat (TRM).

Planning Considerations

A lined swale is used to convey concentrated runoff to a stable outlet in situations where a grass swale is inadequate. A lined swale can be lined with concrete, manufactured concrete products, tied concrete block mats, or TRM. The practice Erosion Control Blanket should be referenced for criteria on TRM. Product manufacturers and qualified design professional should be consulted for design requirements for manufactured products. Tied concrete block mats shall have the proper underlayments and/or backings to meet the site specific conditions. Lined swales are generally used in areas where riprap-lined swales are not desired due to aesthetics, safety, or maintenance concerns. Lined swales allow easy maintenance of surrounding vegetation with normal lawn care equipment. The lined swale generally provides a more visually pleasing structure than the riprap linings. Lined swales are especially desirable in areas accessed by small children.

In areas where stormwater infiltration is preferred, riprap and manufactured products should be considered rather than a solid concrete lining.

Design Criteria

Capacity

Lined swales should be capable of passing the peak flow expected from a 10-year 24-hour duration storm.

Adjustments should be made for release rates from structures and other drainage facilities. Swales shall also be designed to comply with local stormwater ordinances and should be designed for greater capacity whenever there is danger of flooding or out of bank flow cannot be tolerated.

Peak rates of runoff values used to determine the capacity requirements should be calculated using accepted engineering methods. Some accepted methods are:

- Natural Resources Conservation Service, Engineering Field Manual for Conservation Practices, Chapter 2 Estimating Runoff.
- Natural Resources Conservation Service, formerly Soil Conservation Service, Technical Release 55, Urban Hydrology for Small Watersheds.
- Other comparable methods.

Slope (concrete lined swale)

This practice only applies to paved flumes that are installed on slopes of 25% or less. Slopes steeper than this should be designed by a qualified design professional.

The slope in feet per 100 feet of length can be determined from a topographic map of the site or from a detailed survey of the planned lined swale location.

Cross Section (concrete lined swale)

With peak flow (capacity) and slope known, the paved flume cross section can be determined by using Figure LS-1 through LS-3

Concrete

Flumes should be constructed of concrete with a minimum 28-day compressive strength of 3,000 psi. Flumes shall have a minimum concrete thickness of 4".

Cutoff Walls (concrete lined swale)

Cutoff walls shall be constructed at the beginning and end of every flume except where the flume connects with a catch basin or inlet.

Alignment (concrete lined swale)

Keep paved flumes as straight as possible because they often carry supercritical flow velocities.

Inlet Section (concrete lined swale)

The inlet section to the paved flume should be at least 6 feet long and have a bottom width equal to twice the bottom width of the flume itself. The bottom width should transition from twice the flume bottom width to the flume bottom width over the 6 feet length.

Outlet (concrete lined swale)

Outlets of paved flumes shall be protected from erosion. The standard for Outlet Protection can be used to provide this protection. A method to dissipate the energy of low flows is to bury the last section of the flume in the ground. This will usually force the development of a “scour hole” which will stabilize and serve as a plunge basin. For the design of large capacity flumes, it may be necessary to design a larger energy dissipater at the outlet.

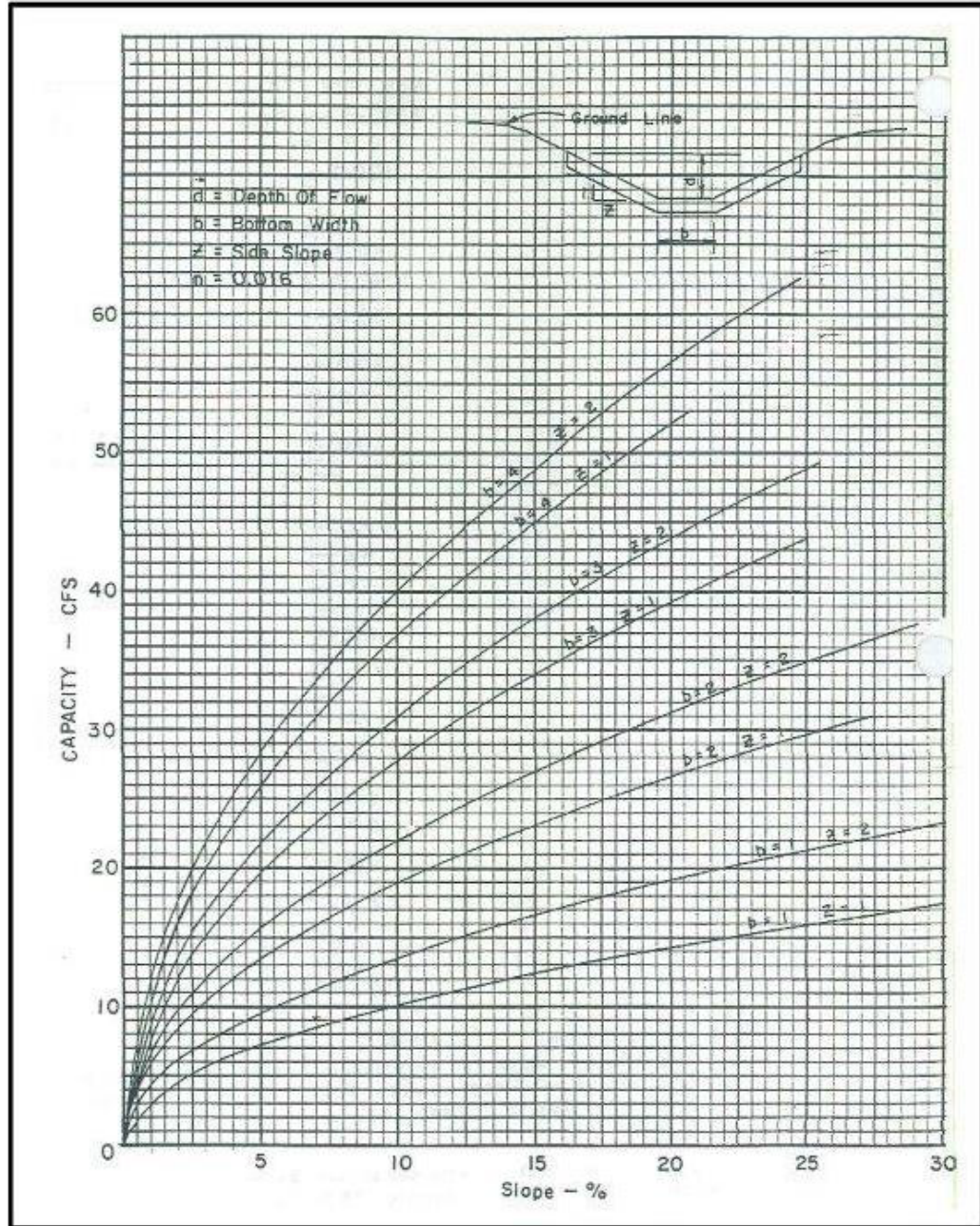

Figure LS-1 Capacity Graph for Concrete Flumes (Depth of Flow = 0.50 Feet)

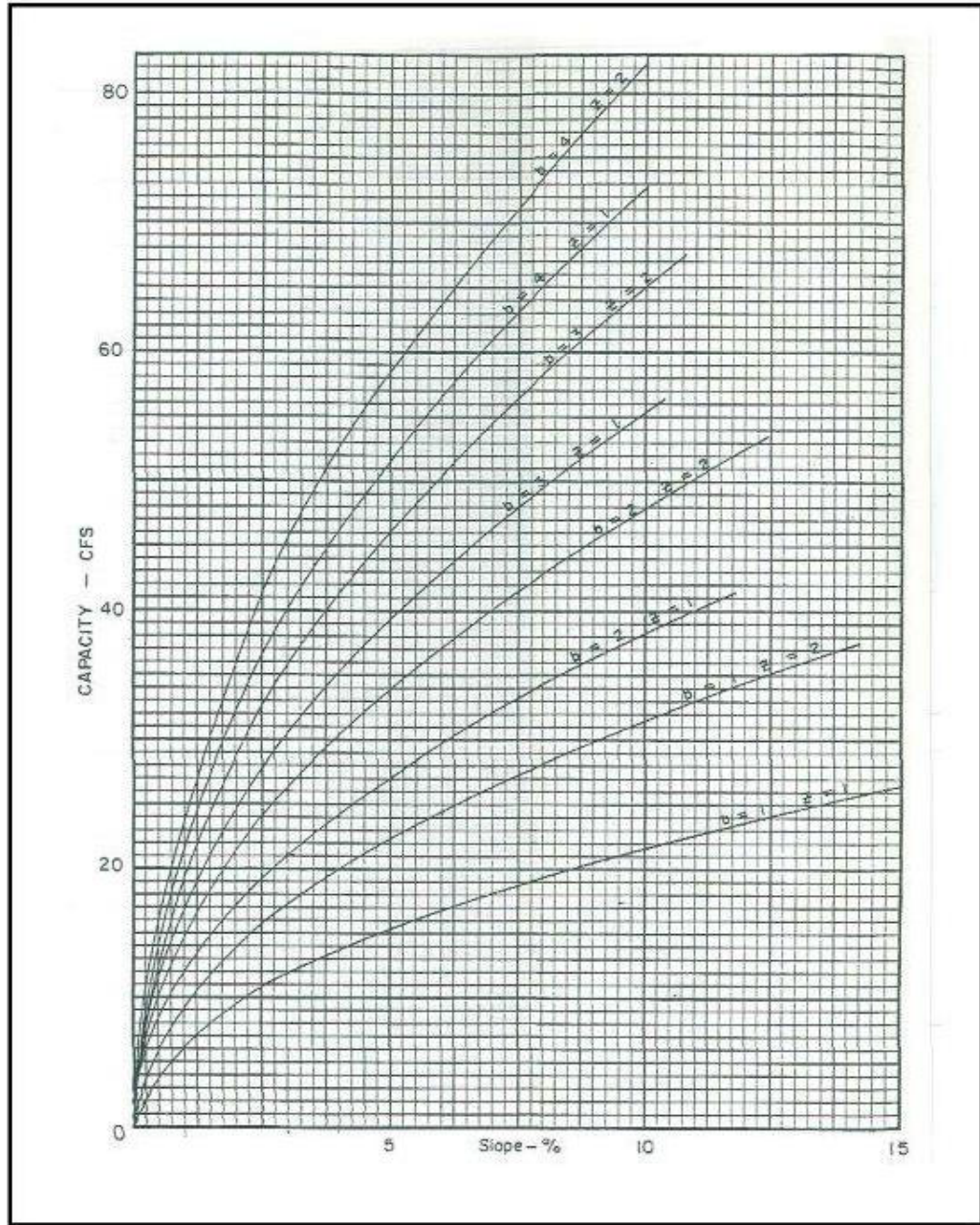

Figure LS-2 Capacity Graph for Concrete Flumes (Depth of Flow = 0.75 Feet)

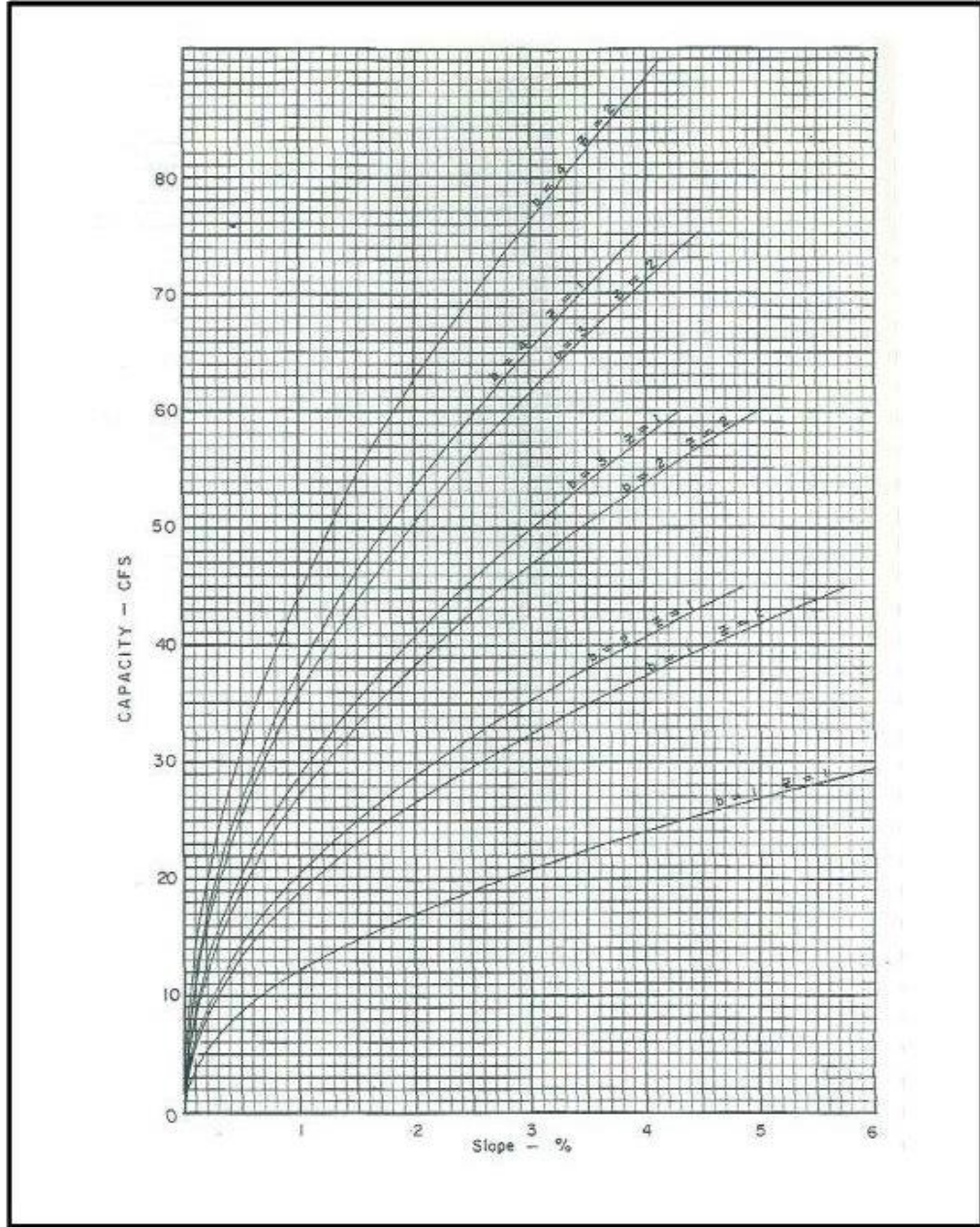

Figure LS-3 Capacity Graph for Concrete Flumes (Depth of Flow = 1.00 Feet)

Outlet Protection (OP)



Practice Description

Outlet Protection is an erosion control practice designed to prevent erosion at the outlet of a channel or conduit by reducing the velocity of flow and dissipating the energy. This practice applies wherever high velocity discharge must be released on erodible material.

Planning Considerations

Outlet protection measures usually consist of a riprap-lined apron, a reinforced concrete flume with concrete baffles, a reinforced concrete box with chambers or baffles and possibly pre-manufactured products.

The outlets of pipes and structurally lined channels are points of critical erosion potential. Stormwater which is transported through man-made conveyance systems at design capacity generally reaches a velocity which exceeds the ability of the receiving channel or area to resist erosion. To prevent scour at stormwater outlets, a flow transition structure is required which will absorb the initial impact of the flow and reduce the flow velocity to a level which will not erode the receiving channel or area of discharge.

The most commonly used structure for outlet protection is an erosion resistant lined apron. These aprons are generally lined with loose rock riprap, grouted riprap, or concrete. They are constructed at zero grade for a distance which is related to the outlet flow rate and the tailwater level. Criteria for designing these structures are contained in this practice. Several outlet conditions are shown in Figure OP-1. Example design problems for outlet protection are found at the end of this practice.

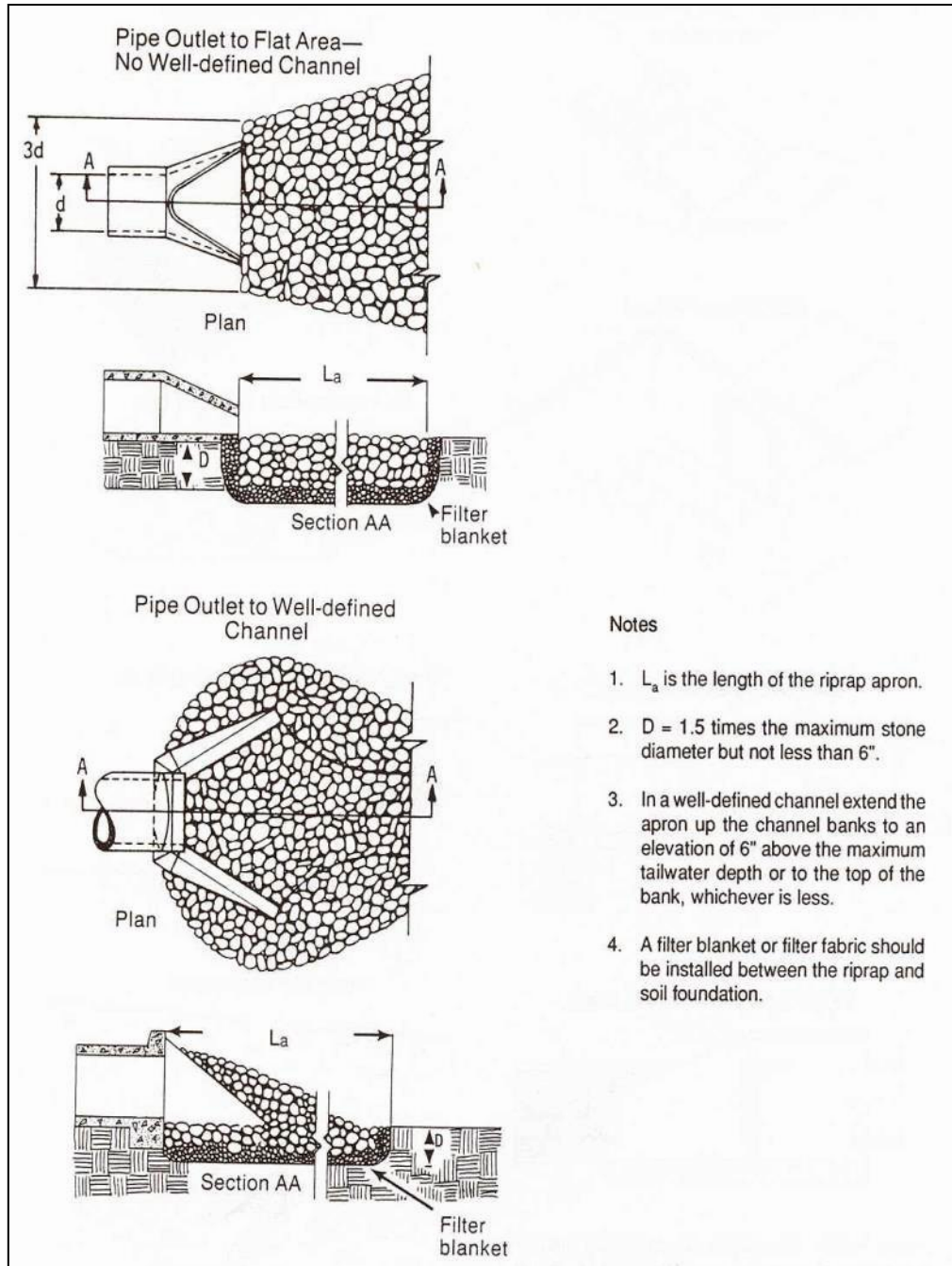

Figure OP-1 Pipe Outlet Conditions

Where the flow is excessive for the economical use of an apron, excavated stilling basins may be used. Acceptable designs for stilling basins may be found in the following documents available from the U. S. Government Printing Office.

- 1) Hydraulic Design of Energy Dissipaters for Culverts and Channels, Hydraulics Engineering Circular No.14, U. S. Department of Transportation, Federal Highway Administration.

- 2) Hydraulic Design of Stilling Basins and Energy Dissipaters,
Engineering Monograph No.25 U. S. Department of Interior-Bureau
of Reclamation.

Design Criteria

Structurally lined aprons at the outlets of pipes and paved channel sections should be designed according to the following criteria:

Pipe Outlets

Capacity

The structurally lined apron should have the capacity to carry the peak stormflow from the 25-year 24-hour frequency storm or the storm specified in state laws or local ordinances or the design discharge of the water conveyance structure, whichever is greatest.

Tailwater

The depth of tailwater immediately below the pipe outlet must be determined for the design capacity of the pipe. Manning's Equation may be used to determine tailwater depth. Manning's Equation may be found in the practice Grass Swales. If the tailwater depth is less than half the diameter of the outlet pipe, it shall be classified as a Minimum Tailwater Condition. If the tailwater depth is greater than half the pipe diameter, it shall be classified as a Maximum Tailwater Condition. Pipes which outlet to flat areas, with no defined channel, may be assumed to have a Minimum Tailwater Condition.

Apron Length

The apron length should be determined from Figure OP-2 or OP-3 according to the tailwater condition.

Apron Thickness

The apron thickness should be determined by the maximum stone size (d_{max}), when the apron is lined with riprap. The maximum stone size shall be $1.5 \times d_{50}$ (median stone size), as determined from Figure OP-2 or OP-3. The apron thickness shall be $1.5 \times d_{max}$.

When the apron is lined with concrete, the minimum thickness of the concrete shall be 4".

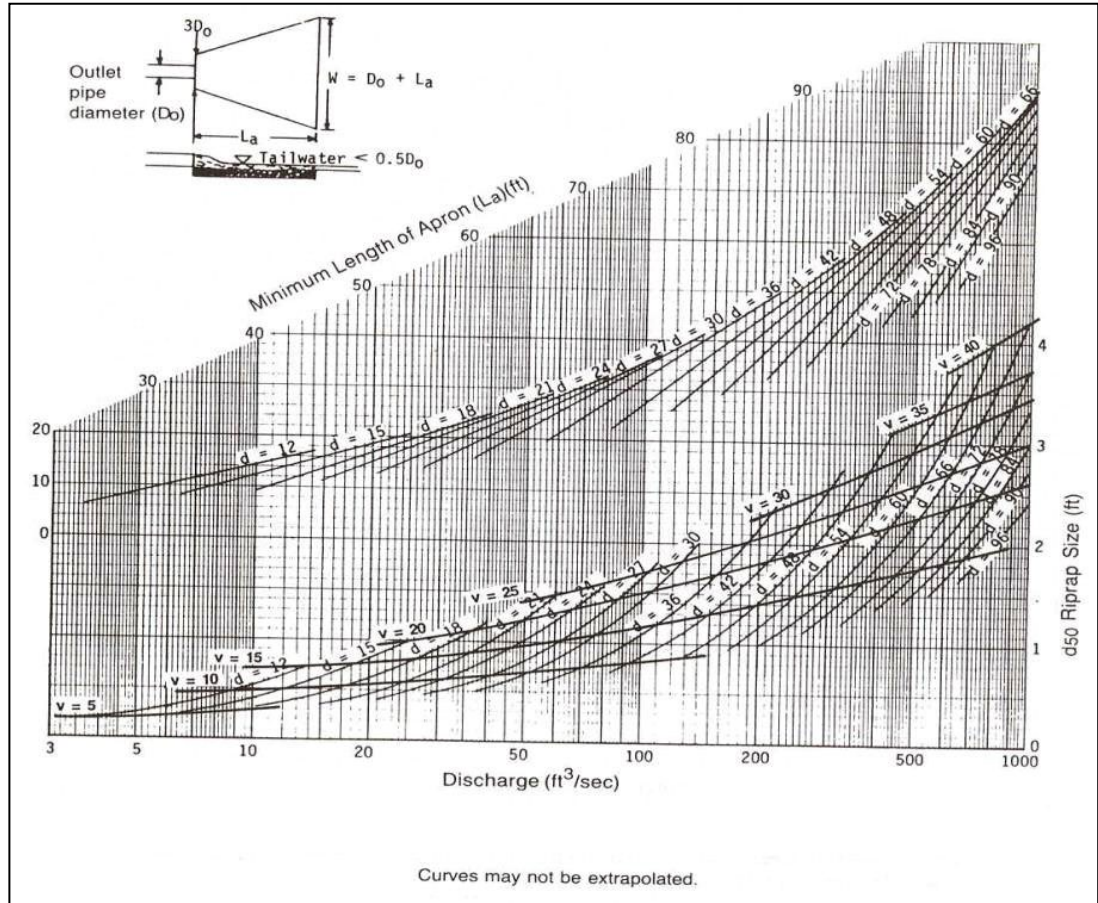

Figure OP-2 Outlet Protection Design for Tailwater < 0.5 Diameter

Apron Width

If the pipe discharges directly into a well-defined channel, the apron should extend across the channel bottom and up the channel banks to an elevation 1 foot above the maximum tailwater depth or to the top of the bank, whichever is the least.

If the pipe discharges onto a flat area with no defined channel, the width of the apron should be determined as follows:

- The upstream end of the apron, adjacent to the pipe, should have a width 3 times the diameter of the outlet pipe.
- For a Minimum Tailwater Condition, the downstream end of the apron should have a width equal to the pipe diameter plus the length of the apron obtained from the figures.
- For a Maximum Tailwater Condition, the downstream end shall have a width equal to the pipe diameter plus 0.4 times the length of the apron from Figures OP-2 or OP-3.

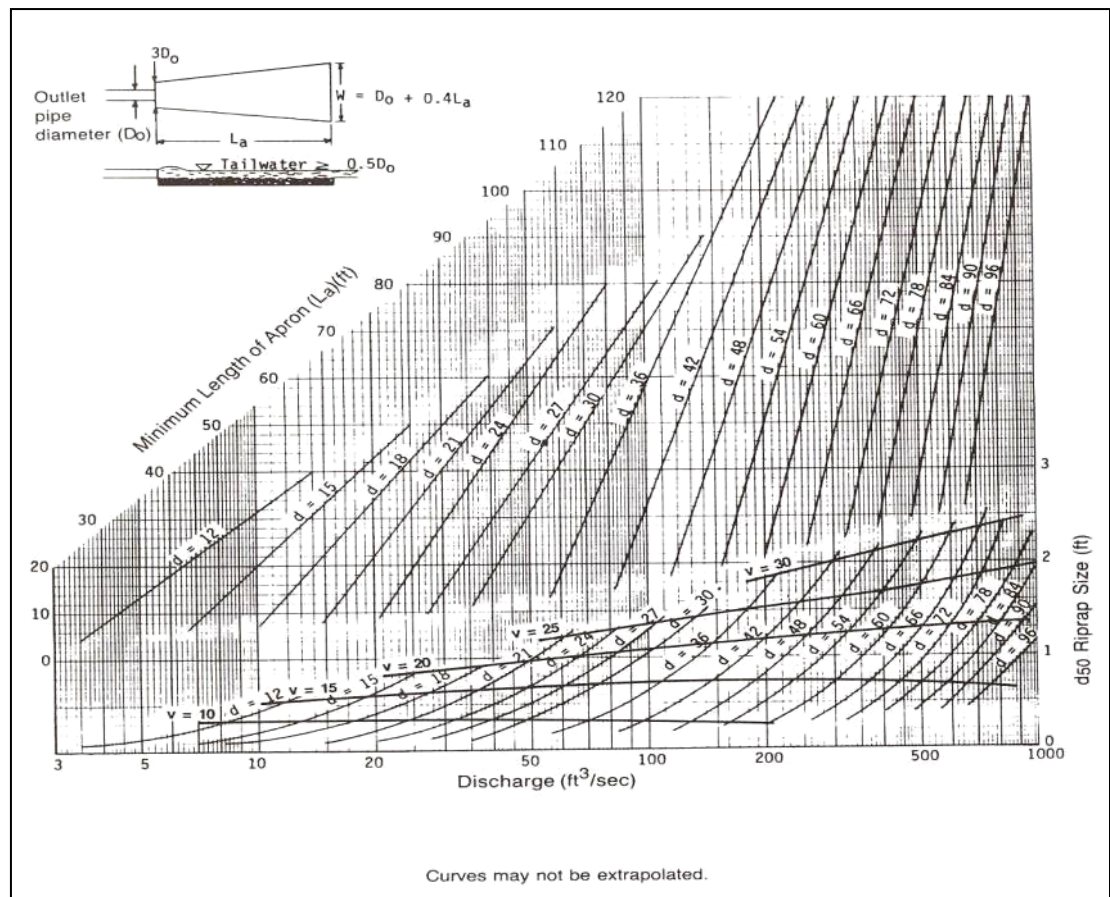

Figure OP-3 Outlet Protection Design for Tailwater ≥ 0.5 Diameter

Bottom Grade

The apron should be constructed with no slope along its length (0.0% grade). The invert elevation of the downstream end of the apron shall be equal to the elevation of the invert of the receiving channel. There shall be no overfall at the end of the apron.

Side Slope

If the pipe discharges into a well-defined channel, the side slopes of the channel should not be steeper than 2:1 (Horizontal:Vertical).

Alignment

The apron should be located so that there are no bends in the horizontal alignment.

Geotextile

When riprap is used to line the apron, non-woven geotextile should be used as a separator between the graded stone, the soil subgrade, and the abutments. Geotextile should be placed immediately adjacent to the subgrade without any voids between the fabric and the subgrade. The geotextile will prevent the migration of soil particles from the subgrade into the graded stone. The geotextile shall be of the strength and durability required for the project to ensure the aggregate and soil base are stable. Generally, the non-woven geotextile should meet the requirements found in AASHTO M288 for a Class 2 separation geotextile.

Materials

The apron may be lined with loose rock riprap, grouted riprap, or concrete. The median sized stone for riprap should be determined from the curves on Figure OP-2 and OP-3 according to the tailwater condition.

After the median stone size is determined, the gradation of rock to be used should be specified using Tables OP-2 and OP-3. Table OP-2 is used to determine the weight of the median stone size (d_{50}). Using this median weight, a gradation can be selected from Table OP-3, which shows the commercially available riprap gradations as classified by the Alabama Department of Transportation.

Stone for riprap should consist of field stone or rough unhewn quarry stone of approximately rectangular shape. The stone should be hard and angular and of such quality that it will not disintegrate on exposure to water or weathering and it shall be suitable in all other respects for the purpose intended. The specific gravity of the individual stones should be at least 2.5.

When the apron is lined with concrete, the concrete should have a minimum compressive strength at 28 days of 3000 pounds per square inch. American Concrete Institute guidelines should be used to design concrete structures and reinforcement. As a minimum, the concrete should be reinforced with steel welded wire fabric.

Table OP-2 Size of Riprap Stones

Weight (lbs.)	Mean Spherical Diameter (feet)	Rectangular Shape	
		Length (feet)	Width, Height (feet)
50	0.8	1.4	0.5
100	1.1	1.75	0.6
150	1.3	2.0	0.67
300	1.6	2.6	0.9
500	1.9	3.0	1.0
1000	2.2	3.7	1.25
1500	2.6	4.7	1.5
2000	2.75	5.4	1.8
4000	3.6	6.0	2.0
6000	4.0	6.9	2.3
8000	4.5	7.6	2.5
20000	6.1	10.0	3.3

Table OP-3 Graded Riprap

Class	Weight (lbs.)					
	d ₁₀	d ₁₅	d ₂₅	d ₅₀	d ₇₅	d ₉₀
1	10	-	-	50	-	100
2	10	-	-	80	-	200
3	-	25	-	200	-	500
4	-	-	50	500	1000	-
5	-	-	200	1000	-	2000

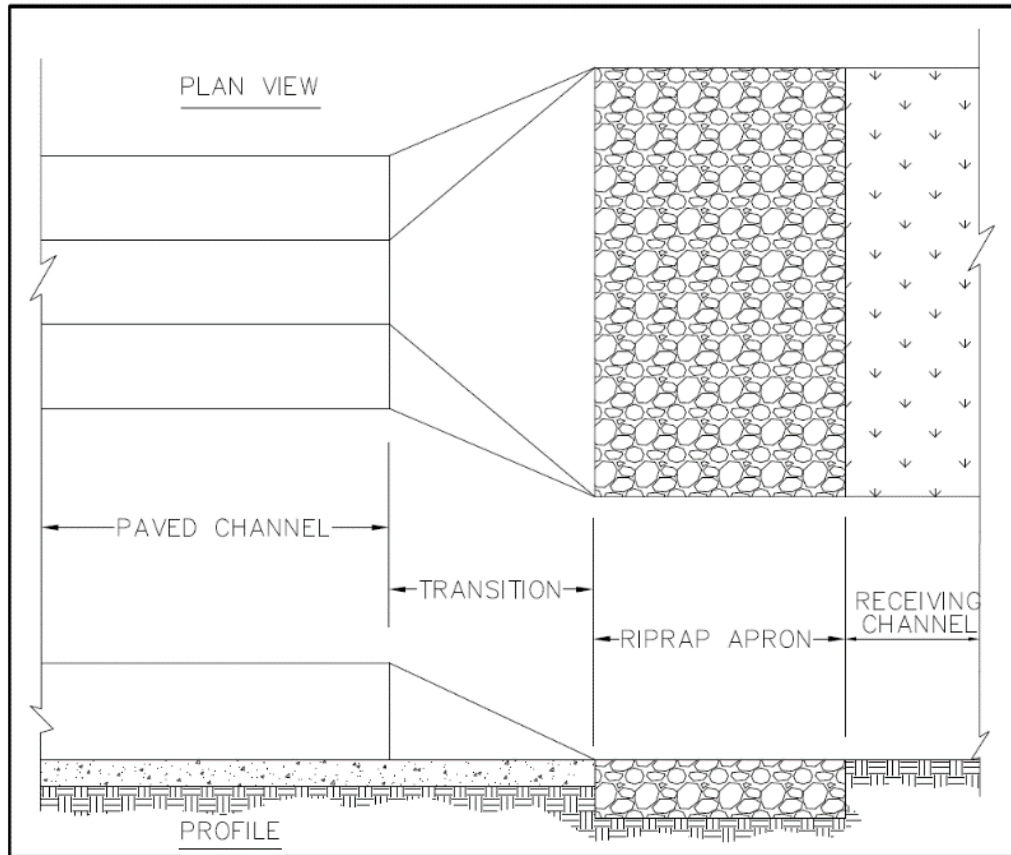

Figure OP-4 Paved Channel Outlet

- 1) The flow velocity at the outlet of paved channels flowing at design capacity should not exceed the velocity, which will cause erosion and instability in the receiving channel.
- 2) The end of the paved channel should merge smoothly with the receiving channel section. There should be no overfall at the end of the paved section. Where the bottom width of the paved channel is narrower than the bottom width of the receiving channel, a transition section should be provided. The maximum side divergence of the transition shall be 1 in 3F where

$$F = v/gd, \text{ and}$$

$$F = \text{Froude no.}$$

$$V = \text{Velocity at beginning of transition (ft./sec.)}$$

$$d = \text{Depth of flow at beginning of transition (feet.)}$$

$$g = 32.2 \text{ ft./sec.}^2$$

- 3) Bends or curves in the horizontal alignment of the transition are not allowed unless the Froude no. (F) is 0.8 or less, or the section is specifically designed for turbulent flow.

Example Design Problems

Example 1

Given: An 18" pipe discharges 24 cu. ft/sec at design capacity onto a grassy slope (no defined channel).

Find: The required length, width and median stone size (d_{50}) for a riprap-lined apron.

Solution

Since the pipe discharges onto a grassy slope with no defined channel, a Minimum Tailwater Condition may be assumed.

From Figure OP-2, an apron length (L_a) of 20 feet and a median stone size (d_{50}) of 0.8 feet is determined.

The upstream apron width equals 3 times the pipe diameter: $3 \times 1.5 \text{ feet} = \underline{4.5 \text{ feet}}$.

The downstream apron width equals the apron length plus the pipe diameter: $20 \text{ feet} + 1.5 \text{ feet} = \underline{21.5 \text{ feet}}$.

Example 2

Given: The pipe in example No. 1 discharges into a channel with a triangular cross section, 2 feet deep and 2:1 side slopes. The channel has a 2% slope and an "n" coefficient of 0.045.

Find: The required length, width and the median stone size (d_{50}) for a riprap lining.

Solution

Determine the tailwater depth using Manning's Equation and the Continuity Equation.

$$Q = 1.49/n R^{2/3} S^{1/2} A$$

$$24 = 1.49/n [2d/4.47]^{2/3} (.02)^{1/2} (2d^2)$$

where, d = depth of tailwater
 $d = 1.74 \text{ feet.}^*$

*Since d is greater than half the pipe diameter, a Maximum Tailwater Condition exists.

From Figure OP-3, a median stone size (d_{50}) of 0.5 feet. and an apron length (L_a) of 41 feet. is determined.

The entire channel cross section should be lined since the maximum tailwater depth is within 1-foot of the top of the channel.

This Page Intentionally Left Blank

Riprap-lined Swale (RS)



Practice Description

A riprap-lined swale is a natural or constructed channel with an erosion-resistant rock lining designed to carry concentrated runoff to a stable outlet. This practice applies where grass swales are unsuitable because of conditions such as steep channel grades, prolonged flow areas, soils that are too erodible or not suitable to support vegetation or insufficient space.

Planning Considerations

Swales should be carefully built to the design cross section, shape and dimensions. Swales are hydraulic structures and as such depend upon the hydraulic parameters to serve satisfactorily. Swales may be used to:

- Serve as outlets for diversions and sediment control basins and stormwater detention basins.
- Convey water collected by road ditches or discharged through culverts.
- Rehabilitate natural draws and gullies carrying concentrations of runoff.

The design of a swale cross section and lining is based primarily upon the volume and velocity of flow expected in the swale. Riprap lined swales should be used where velocities are in the range of 5 to 10 ft/sec.

Besides the primary design considerations of capacity and velocity, many other important factors should be taken into account when selecting a cross section. These factors include land availability, compatibility with land use and surrounding environment, safety, maintenance requirements and outlet conditions, etc.

Riprap lined swales are trapezoidal in shape. Trapezoidal swales are often used where the quantity of water to be carried is large and conditions require that it be carried at a relatively high velocity.

Outlet conditions for all swales should be considered. This is particularly important for the transition from the riprap lining to a vegetative lining. Appropriate measures must be taken to dissipate the energy of the flow to prevent scour of the receiving swale.

Design Criteria

Capacity

Lined swales shall be designed to convey the peak rate of runoff from a 10-year 24-hour rainfall event. Adjustments should be made for release rates from structures and other drainage facilities. Swales should also be designed to comply with local stormwater ordinances.

Swales should be designed for greater capacity whenever there is danger of flooding or out of bank flow cannot be tolerated. The maximum capacity of the swale flowing at design depth should be 200 cubic ft/sec.

Peak rates of runoff values used to determine the capacity requirements should be calculated using accepted engineering methods. Some accepted methods are:

- Natural Resources Conservation Service, National Engineering Handbook Series, Part 650, Engineering Field Handbook, Chapter 2, Estimating Runoff.
- Natural Resources Conservation Service, formerly Soil Conservation Service, Technical Release 55, Urban Hydrology for Small Watersheds.
- Other comparable methods.

Cross section

The swale cross section should be trapezoidal in shape. The steepest permissible side slope of the swale should be 2:1. A bottom width should be selected based on area available for installation of the swale and available rock sizes. The bottom width will be used in determining stable rock size and flow depth.

Depth

Design flow depth should be determined by the following formula:

$$z = [n(q)/1.486(S)^{0.50}]^{3/5}$$

S = Bed slope, ft./ft.

z = Flow depth, ft.

q = Unit discharge, ft³/s/ft

(Total discharge ÷ Bottom width)

n = Manning's coefficient of roughness (see formula under velocities)

The design water surface elevation of a swale receiving water from other tributary sources should be equal to or less than the design water surface elevation of the contributing source. The design water surface elevation of contributing and receiving waters should be the same, whenever practical. A minimum depth may be necessary to provide adequate outlets for subsurface drains and tributary swales.

Freeboard

The minimum freeboard is 0.25 feet. Freeboard is not required on swales with less than 1% slope and where out-of-bank flow will not be damaging and can be tolerated from an operational point of view.

Stable Rock Size

Stable rock sizes, for rock lined swales having gradients between 2 percent and 40 percent should be determined using the following formulas from Design of Rock Chutes by Robinson, Rice, and Kadavy.

$$\text{For swale slopes between 2\% and 10\%: } d_{50} = [q(S)^{1.5}/4.75(10)^{-3}]^{1/1.89}$$

$$\text{For swale slopes between 10\% and 40\%: } d_{50} = [q(S)^{0.58}/3.93(10)^{-2}]^{1/1.89}$$

d_{50} = Particle size for which 50 % of the sample is finer, inch

S = Bed slope, ft./ft.

q = Unit discharge, ft³/s/ft.

(Total discharge ÷ Bottom width)

After the stable median stone size is determined, the gradation of rock to be used should be specified using Tables RS-1 and RS-2. Table RS-1 is used to determine the weight of the median stone size (d_{50}). Using this median weight, a gradation can be selected from Table RS-2, which shows the commercially available riprap gradations as classified by the Alabama Department of Transportation.

Table RS-1 Size of Riprap Stones

Weight (lbs.)	Mean Spherical Diameter (feet)	Rectangular Shape	
		Length (feet)	Width, Height (feet)
50	0.8	1.4	0.5
100	1.1	1.75	0.6
150	1.3	2.0	0.67
300	1.6	2.6	0.9
500	1.9	3.0	1.0
1000	2.2	3.7	1.25
1500	2.6	4.7	1.5
2000	2.75	5.4	1.8
4000	3.6	6.0	2.0
6000	4.0	6.9	2.3
8000	4.5	7.6	2.5
20000	6.1	10.0	3.3

Table RS-2 Graded Riprap

Class	Weight (lbs.)					
	d ₁₀	d ₁₅	d ₂₅	d ₅₀	d ₇₅	d ₉₀
1	10	-	-	50	-	100
2	10	-	-	80	-	200
3	-	25	-	200	-	500
4	-	-	50	500	1000	-
5	-	-	200	1000	-	2000

Velocities

Velocities should be computed by using Manning's Formula with a coefficient of roughness, "n", as follows:

$$n = 0.047(d_{50} \cdot S)^{0.147}$$

Applies on slopes between 2 and 40% with a rock mantle thickness of $2 \times d_{50}$ where:

$$d_{50} = \text{median rock diameter (inch), } S = \text{lined section slope (ft./ft.)} \\ (.02 \leq S \leq .4)$$

Velocities exceeding critical velocity should be restricted to straight reaches.

Waterways or outlets with velocities exceeding critical velocity should discharge into an outlet protection structure to reduce discharge velocity to less than critical (see Outlet Protection practice).

Lining Thickness

The minimum lining thickness should be equal to the maximum stone size of the specified riprap gradation plus the thickness of any required filter or bedding.

Lining Durability

Stone for riprap should consist of field stone or rough unhewn quarry stone of approximately rectangular shape. The stone should be hard and angular and of such quality that it will not disintegrate on exposure to water or weathering and it should be suitable in all other respects for the purpose intended. The specific gravity of the individual stones should be at least 2.5.

Geotextiles

Non-woven geotextiles should be used where appropriate as a separator between rock and soil to prevent migration of soil particles from the subgrade, through the lining material. The geotextile shall be of the strength and durability required for the project to ensure the rock and soil base are stable. Generally, the non-woven geotextile should meet the requirements found in AASHTO M288 for a Class 2 separation geotextile.

Filters or Bedding

Filters or bedding should be used where needed to prevent piping. Filters should be designed according to the requirements contained in the Subsurface Drain Standard. The minimum thickness of a filter or bedding should be 6".

This Page Intentionally Left Blank

Subsurface Drain (SD)



Practice Description

A subsurface drain is a perforated pipe and/or a continuous layer of porous material installed below the ground surface that intercepts, collects and carries excessive groundwater to a stable outlet. The practice improves soil moisture, vegetative growth, and ground stability. Subsurface drains may reduce wet ground from interfering with construction activities. This practice applies where groundwater is at or near the ground surface or where adequate drainage cannot be provided for surface runoff.

Planning Considerations

To properly design and install this practice, a detailed site investigation will be required. This investigation should include a site survey to determine the location of the area to be drained, the depth of the area to be drained, topography of the area to be drained and the outlet of the drain system, and soils at the site.

When considering use of this practice, the qualified design professional should consider the intended use of the area to be drained. Base flow and interflow of groundwater may increase with installation of this practice due to excess soil water being removed. Groundwater recharge may also be reduced by this practice. Finally, surface runoff may increase due to this practice reducing deep percolation at the site.

Drains may be constructed using a sand/gravel-filled trench, perforated pipe in sand/gravel bedding or manufactured drain panel products.

All federal, state, and local laws and regulations should be adhered to when planning and installing this practice.

Design Criteria

Layout and Depth

In the absence of site specific information, a depth of 3 feet and a spacing of 50 feet for drains should be adequate. However, it is recommended that site specific information be obtained. Typical details of subsurface drain construction can be seen in Figures SD-1 and SD-2. The following guidelines should be followed.

Depth

The depth the drain is installed will determine how much the water table is lowered.

The minimum depth for the drain is 2 feet under normal conditions.

The maximum depth is limited by the depth of the impermeable layer, and if a pipe is used in the drain, by the allowable load on the pipe used.

Spacing

The permeability of the soil at the site and the depth of the drain will determine the spacing of the drain.

Multiple Drains

In some cases, more than one drain will be needed to achieve the desired results. The first drain should be installed, and additional drains should only be added if seepage or high-water table problems continue.

Location

Drains should be located a minimum of 50 feet from any trees to prevent damage to the trees.

Grade

In areas where sedimentation is not likely, the minimum grades should be based on site conditions and a velocity of not less than 0.5 ft/sec. Where a potential for sedimentation exists, a velocity of not less than 1.4 ft/sec should be used to establish the minimum grades if site conditions permit. Otherwise, provisions should be made for prevention of sedimentation by filters or collection and periodic removal of sediment from installed traps. Steep grades should be avoided.

Gravel Bedding

Typically, 6" or more of coarse sand and 6" of gravel is placed completely around the drain and graded to prevent the infiltration of fine-grained soils into the drain.

Filters and Filter Material

Filters will be used around conduits, as needed, to prevent movement of the surrounding soil material into the conduit. The need for a filter will be determined by the characteristics of the surrounding soil material (i.e., permeability), site conditions, and the velocity of flow in the conduit.

A suitable filter should be specified if:

- Local experience indicates a need.
- Soil materials surrounding the conduit are dispersed clay, low plasticity silts, or fine sands (ML or SM with P.I. less than 7).
- Where deep soil cracking is expected.
- Where the method of installation may result in voids between the conduit and backfill material.

The filter can be a sand-gravel combination with or without non-woven geotextile. If a geotextile is used it should meet the requirements of the material table found in the Outlet Protection practice. Caution should be used when selecting geotextile filter fabric since small soil particles can clog the fabric causing the drain to be ineffective. If a sand-gravel filter is specified, the filter gradation will be based on the gradation of the base material surrounding the conduit within the following limits:

- D_{15} size smaller than 7 times d_{95} size, but not smaller than 0.6 mm.
- D_{15} size larger than 4 times d_{15} size.
- Less than 5% passing No. 200 sieve.
- Maximum size smaller than 1.5".

D represents the filter material and d represents the surrounding base material. The number following each letter is the percent of the sample, by weight, that is finer than that size. For example, D_{15} size means that 15 percent of the filter material is finer than that size.

Specified filter material must completely encase the conduit so that all openings are covered except that the top of the conduit and side filter material may be covered by a sheet of plastic or similar impervious material to reduce the quantity of filter material required.

Clean-outs

In long sections of drain and in areas where sedimentation is concerned, clean-outs should be installed in the drain to facilitate removal of sediment deposits.

Outlet and Protection

The outlet must be protected against erosion and undermining of the conduit, entry of tree roots, damaging periods of submergence, and entry of rodents or other animals into the subsurface drain. A continuous section of rigid pipe without open joints or perforations will be used at the outlet end of the line and must discharge above the normal elevation of low flow in the outlet ditch. Corrugated plastic tubing is not suitable for the outlet section as it can be damaged by fire and heavy equipment.

Materials

Pipe should be perforated, continuous closed-joint pipes of corrugated plastic, concrete, corrugated metal or bituminous fiber. The pipe should have sufficient strength to withstand the load to be placed on it under the planned installation design. Manufacturer's recommendations should be followed in designing the pipe to withstand design loads.

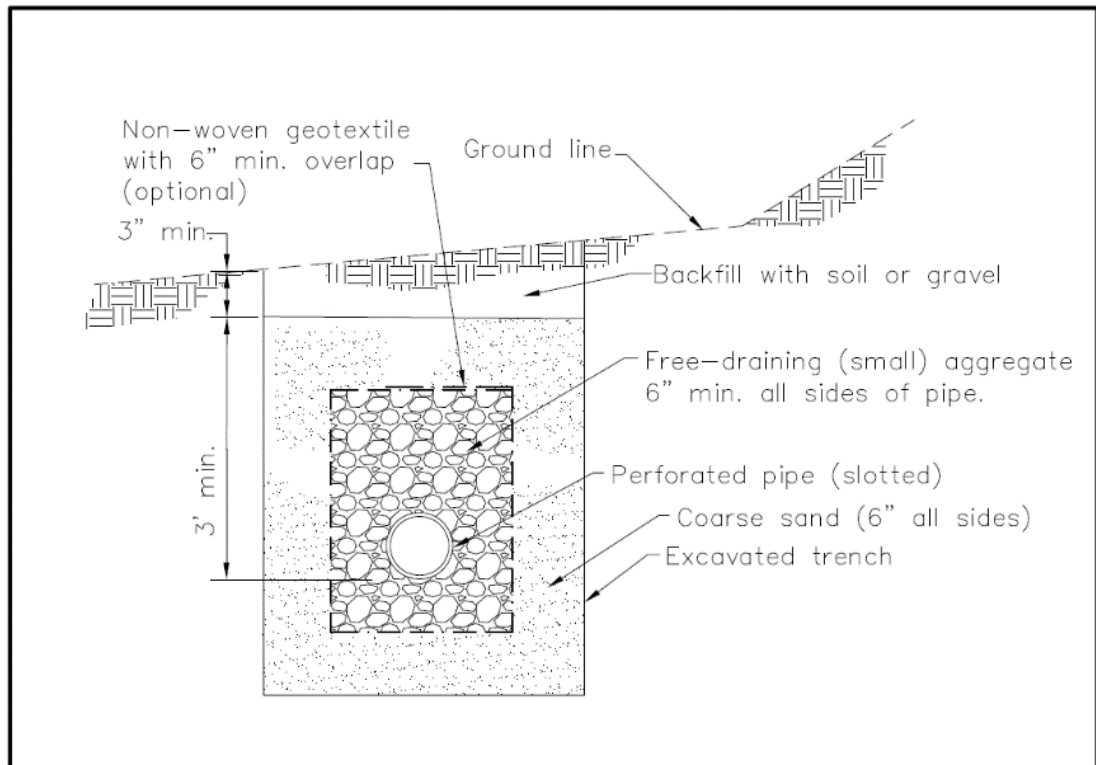

Figure SD-1 Details of Typical Subsurface Drain Construction

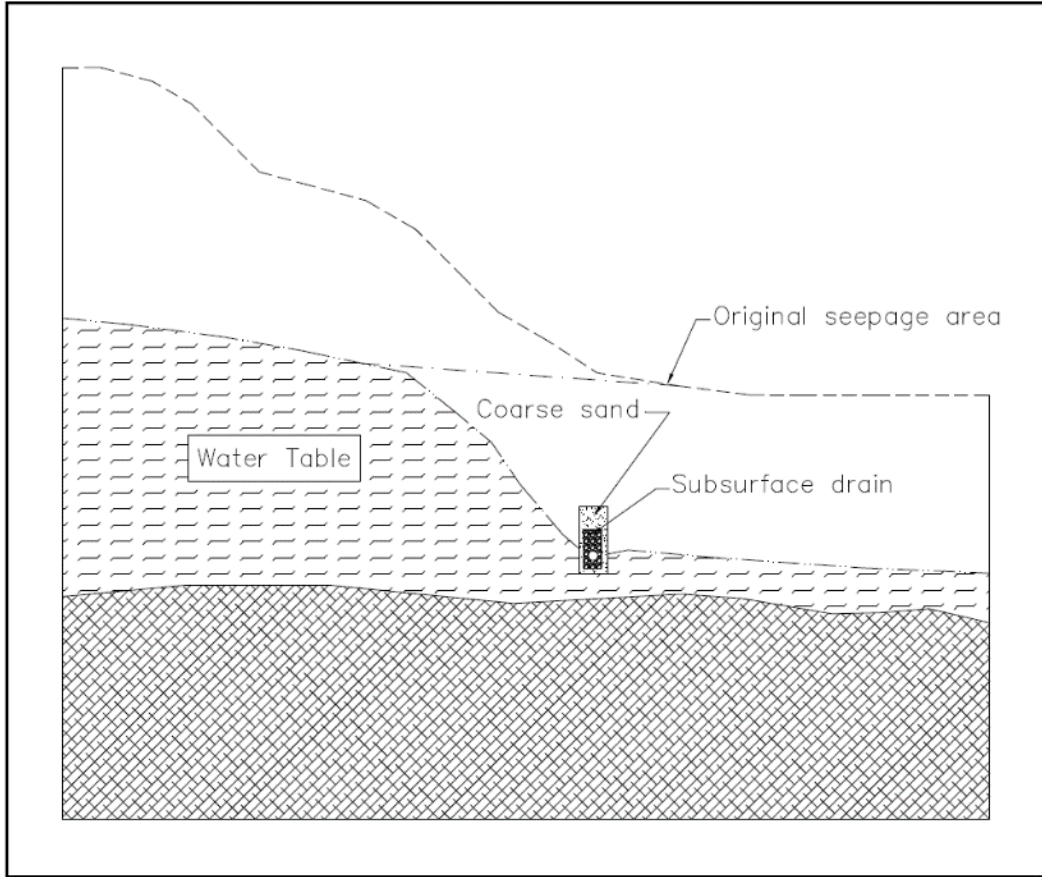

Figure SD-2 Details of Subsurface Drain Construction

This Page Intentionally Left Blank

Temporary Slope Drain (TSD)



Photo courtesy of CPESC, Inc.

Practice Description

A temporary slope drain is a pipe or other conduit designed to convey concentrated runoff down the face of a cut or fill slope without causing erosion. This practice applies wherever concentrated stormwater runoff must be conveyed down a steep slope.

Planning Considerations

There is often a significant lag between the time a cut or fill slope is completed and the time a permanent runoff conveyance system can be installed. During this period, the slope is usually not stabilized and is particularly vulnerable to erosion. This situation also occurs on slope construction which is temporarily delayed before final grade is reached. Temporary slope drains, sometimes called “down drains”, can provide valuable protection of exposed slopes until permanent runoff conveyance structures can be installed. See Figure TSD-1 for typical details of a Temporary Slope Drain.

When used in conjunction with diversions, temporary slope drains can be used to convey stormwater from the entire drainage area above a slope to the base of the slope without erosion. It is very important that these temporary structures be installed properly since their failure will often result in severe gully erosion. The entrance section must be securely entrenched, all connections must be watertight, and the conduit must be securely staked. Prior approval may be required from

local regulatory agencies if the down drain outlet is tied into an existing storm sewer or in areas where municipal stormwater is regulated.

Design Criteria

Drainage Area

The maximum allowable drainage area per drain is 5 acres.

Flexible Conduit

The down drain should consist of heavy duty flexible material designed for this purpose. The diameter of the down drain should be equal over its entire length. Reinforced hold-down grommets should be spaced at 10 feet (or less) intervals with the outlet end securely fastened in place. The conduit should extend beyond the toe of the slope.

Down drains may be sized according to the table TSD-1.

Table TSD-1 Flexible Conduit Diameters

Maximum Drainage Area (Acres)	Pipe Diameter (D) (Inches)
0.5	12
1.5	18
2.5	21
3.5	24
5.0	30

Drains should be designed to convey the peak rate of runoff from a 10-year 24-hour rainfall whenever it is desired to individually design each installation.

Entrance Sections

The entrance to the down drain (Figures TSD-2 and TSD-3) should consist of a Standard Flared End-Section for Metal Pipe culverts. All fittings should be watertight.

The toe plate should be a minimum of 8" deep.

Extension collars should consist of 12" long corrugated metal pipe. Avoid use of helical pipe. Securing straps should be fabric, metal, or other material well suited to providing a watertight connection. The strap should secure at least one corrugation of the extension collar.

Diversion Design

An earthen diversion should be used to direct stormwater runoff into the slope drain and should be constructed according to the Diversion Standard.

The height of the diversion at the centerline of the inlet should be equal to at least the diameter of the pipe (D) plus 12". Where the dike height is greater than 18" at the inlet, it should be level for 3 feet each side of the pipe and be sloped at the rate of 3:1 or flatter to transition with the remainder of the dike.

Outlet Protection

The outlet of the down drain should be protected from erosion as detailed in the Outlet Protection Standard.

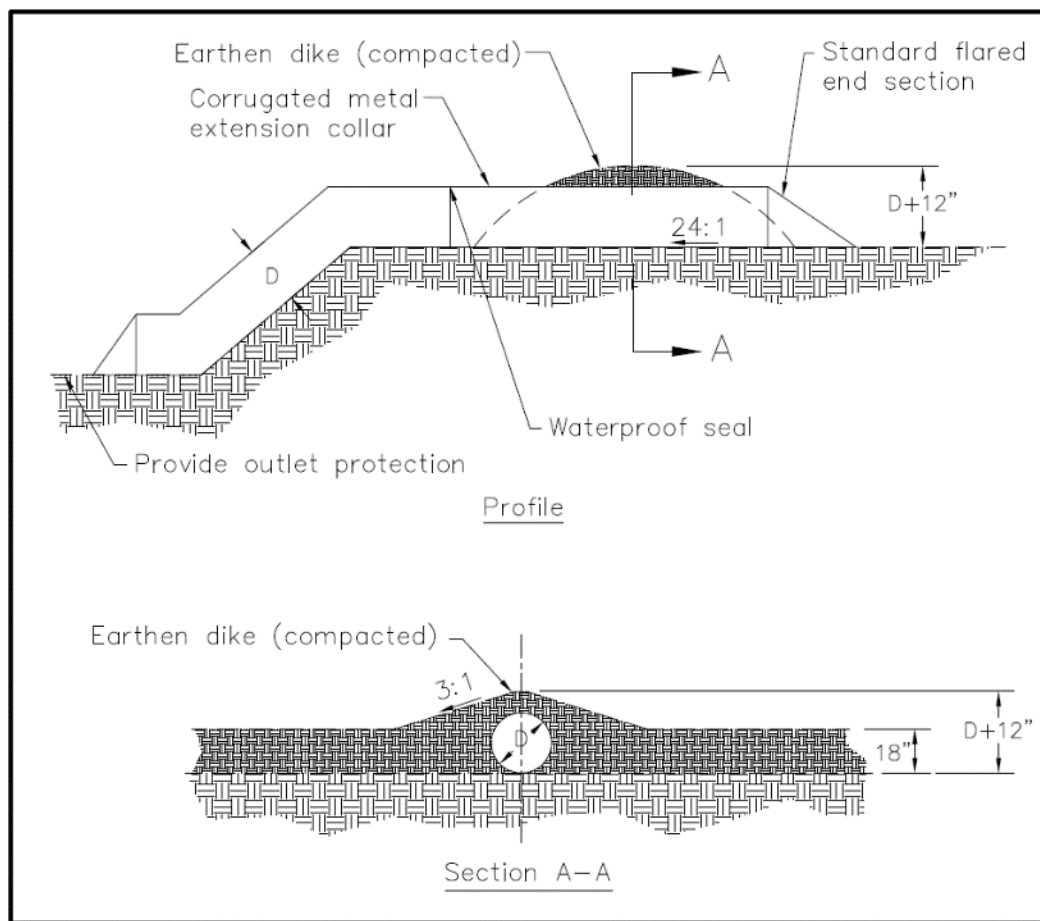

Figure TSD-1 Typical Temporary Slope Drain Detail

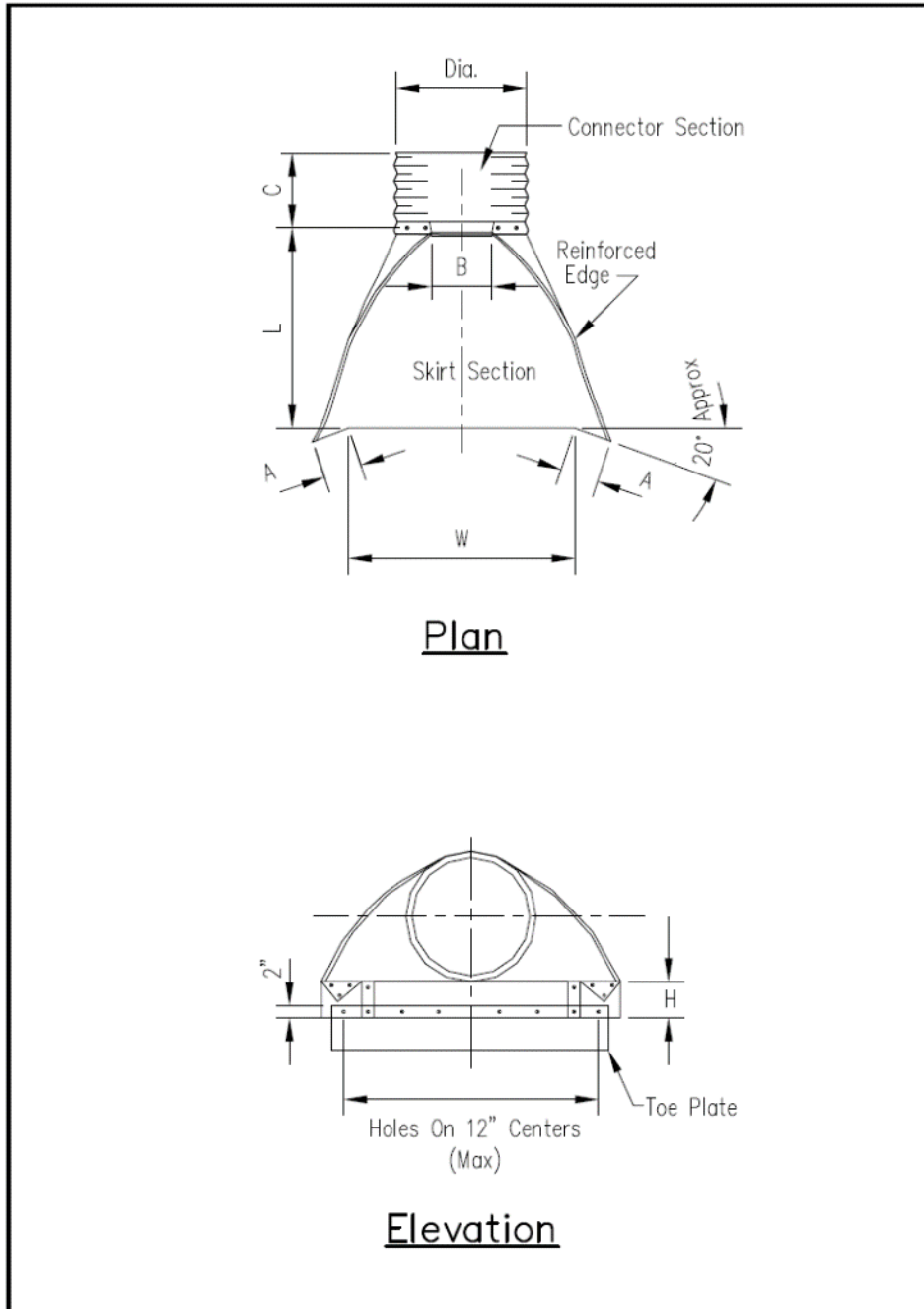

Figure TSD-2 Flared End-Section Detail

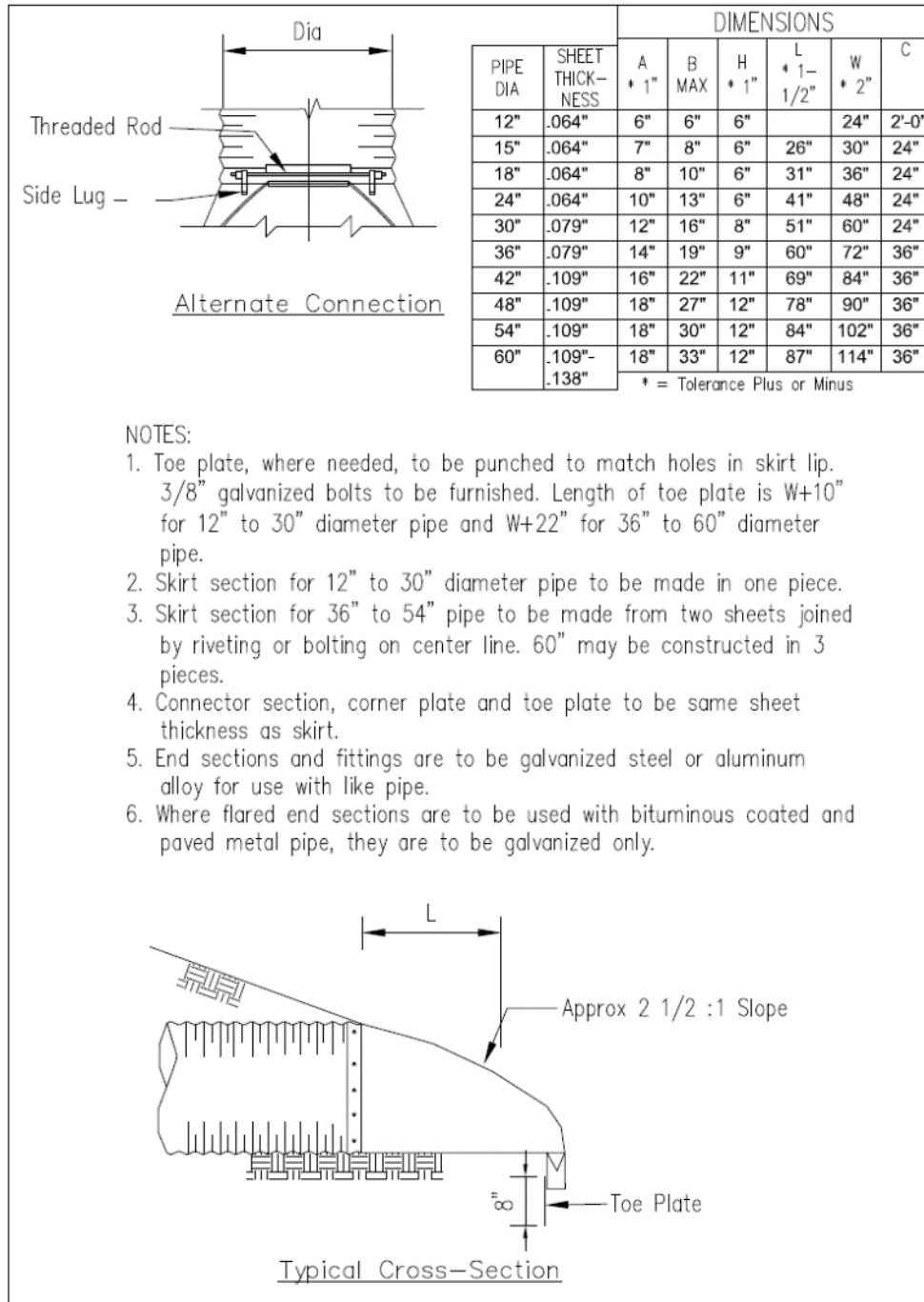

Figure TSD-3 Flared End-Section Details (continued)

This Page Intentionally Left Blank

Brush/Fabric Barrier (BFB)



Practice Description

A brush/fabric barrier is a dam-like structure constructed from woody residue and faced with a non-woven geotextile fabric to provide a temporary sediment basin. This practice is applicable on sites with a small drainage area where brush and other woody debris are available from a clearing and grubbing operation.

Planning Considerations

This practice is intended to be a temporary sediment basin with a limited life span and applicable only for small drainage areas.

The barrier should be located downslope from areas with potential sheet and rill erosion, with adequate storage volume in front of the barrier, and with no more than 2 acres of drainage area.

Adequate woody material from clearing and grubbing required on the site must be available for the construction of the barrier.

The practice should be located and designed so adequate storage volume and detention time can be obtained, and that failure of the barrier will not result in hazard to the public or damage to either work on-site or off-site property.

Design Criteria

Drainage Area

Brush/fabric barriers should be designed with no more than 2 acres of drainage area. A sediment basin should be considered for larger drainage areas (see Sediment Basin).

Structure Life

The design life of the structure should be 1 year or less. The barrier should be removed, and sediment accumulations properly stabilized prior to completion of the construction project.

Sediment Storage

The barrier should be designed to provide 67 cubic yards of sediment storage per acre of disturbed drainage area. Sediment should be removed and properly utilized on site when $\frac{1}{2}$ the sediment storage volume has been filled.

Site Location and Preparation

The site for the barrier should be located so that a basin capable of providing the sediment storage required can be obtained or created. The site for the barrier should be smoothed prior to placement of the brush.

Brush Placement

The barrier should be mostly on a contour or constant elevation with each end of the barrier turned up to a higher elevation so that excessive flows will overtop the barrier instead of bypassing the barrier. Brush should be placed in a longitudinal dense pile with main stems oriented perpendicular to the direction of flow. Generally, the barrier should be at least 3 feet tall, but no more than 6 feet tall. The width of the barrier perpendicular to the direction of flow should be at least 5 feet at its base. Small stems and limbs protruding from the bundle that could damage the fabric should be trimmed. (See Figure BFB-1)

Fabric

The fabric used to face the upstream surface of the brush should be non-woven geotextile. The geotextile shall be of the strength and durability required for the project. Generally, the non-woven geotextile should be an 8-ounce fabric and meet the same requirements as a temporary silt fence found in AASHTO M288.

The fabric to be used should be supplied in lengths and widths to minimize vertical splices and eliminate horizontal splices. The minimum vertical splice overlap should be 3 feet. Vertical splices must be securely fastened to each other so that flows will not short-circuit through the splice.

The fabric should be securely buried at the bottom of an excavated trench that is at least 6" deep in front of the barrier. Prior to compacting backfill in the trench, the

fabric should be securely staked at 3-foot centers with wooden stakes a minimum of 18" long.

The top edge of the fabric should be secured so that it will not sag below the designed storage elevation. The upper edge can be anchored with twine fastened to the fabric and secured to stakes behind the barrier.

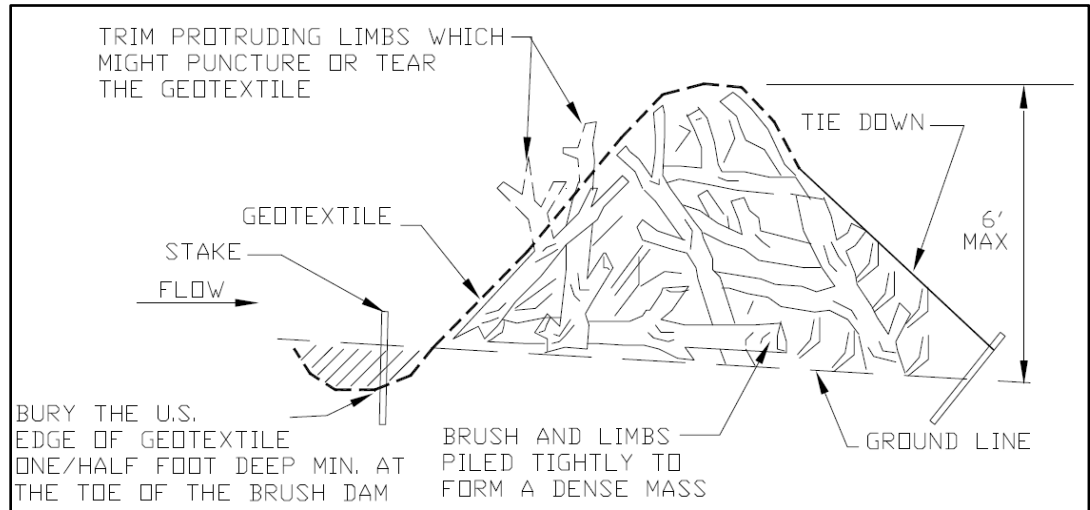

Figure BFB-1 Typical Brush/Fabric Barrier

This Page Intentionally Left Blank

Filter Strip (FS)



Practice Description

A filter strip is a wide belt of vegetation designed to provide infiltration, intercept sediment and other pollutants, and reduce stormwater flow and velocity. Filter strips are similar to grassed swales except that they are designed to intercept overland sheet flow (not channel flow). They cannot treat high velocity flows. Surface runoff must be evenly distributed across the filter strip. This practice applies on construction sites and other disturbed areas.

Planning Considerations

Filter strips provide their maximum benefit when established as early as possible after disturbances begin. This concept should receive strong consideration during the scheduling of practices to be installed. In some instances, the existing vegetation may be preserved to serve as a filter strip.

Filter strips should be strategically located on the contour to reduce runoff and increase infiltration. They should be situated downslope from the disturbed site and where runoff water enters environmentally sensitive areas.

Vegetation may consist of existing cover that is preserved and protected or be planted to establish the strip. Once a concentrated flow channel forms in the filter strip, the filter strip is no longer effective.

Overland flow entering filter strips should be primarily sheet flow. All concentrated flow should be dispersed prior to entering the filter strip.

Flow length should be based on slope percent and length, predicted amount and particle size distribution of sediment delivered to the filter strip, density and height of the filter strip vegetation, and runoff volume.

The slope of the drainage area above a filter strip should be greater than 1% but less than 10%. The ratio of the drainage area to the filter strip area should be less than 10:1. The minimum width of an effective filter strip is 15 feet.

Existing vegetation may be used if it meets stand density and height requirements and has uniform flow through the existing vegetation. The existing vegetation strip must be on a contour to be effective.

Site preparation for filter strips requires that the filter strip be placed on the contour. Variation in placement on the contour should not exceed a 0.5% longitudinal (perpendicular to the flow length) gradient.

All soil amendments should be applied according to a soil test recommendation for the planned vegetation.

The vegetation for filter strips must be permanent herbaceous vegetation of a single species or a mixture of grasses or legumes, which have stiff stems and a high stem density near the ground surface. Stem density should be such that the stem spacing does not exceed 1”.

Design Criteria

Installation (preservation of existing vegetation)

Designate the areas for preserving vegetation on the design plan map.

Indicate in the plan that the designated areas will be fenced or flagged and will not be disturbed. This includes avoiding surface disturbances that affect sheet flow of stormwater runoff and not storing debris from clearing and grubbing, and other construction waste material in the filter strips during construction.

Installation (planting)

Site Preparation

If the upper edge of the filter strip does not have a level edge, remove any obstructions, and grade the upper edge of the filter strip so that runoff evenly enters the filter strip. Fill and smooth any rills and gullies that exist over the filter strip area to ensure that overland flow will discharge across the filter strip along a smooth surface

Seedbed Preparation

Grade and loosen soil to a smooth firm surface to enhance rooting of seedlings and reduce rill erosion. If existing, break up large clods and loosen compacted, hard or

crusted soil surfaces with a disk, ripper, chisel, harrow or other tillage equipment. Avoid preparing the seedbed under excessively wet conditions. For broadcast seeding and drilling, tillage should adequately loosen the soil to a depth of at least 6", alleviate compaction, and smooth and firm the soil for the proper placement of seed.

For no-till drilling, the soil surface does not need to be loosened unless the site has surface compaction. If compaction exists, the area should be chiseled across the slope to a depth of at least 6".

Applying Soil Amendments

Liming

Follow soil test recommendation. If a soil test is not available, use 2 tons/acre of ground agricultural lime on clayey soils (approximately 90 lbs/1000 ft²) and 1 ton/acre on sandy soils (approximately 45 lbs/1000 ft²). Exception: If the cover is tall fescue, use the 2 tons/acre rate (90 lbs/1000 ft²) on both clayey and sandy soils.

Spread the specified amount of lime and incorporate into the top 6" of soil after applying fertilizer.

Fertilizing

Apply fertilizer at rates specified in the soil test recommendation. In the absence of soil tests, use the following as a guide:

Grass alone: 8-24-24 or equivalent - 400 lbs/acre (9.2 lbs/1000 ft²). When vegetation has emerged to a stand and is growing, 30 to 40 lbs/acre (0.8 lb/1000 ft²) of additional nitrogen fertilizer should be applied.

Grass-Legume Mixture: 8-24-24 or equivalent-400 lbs/acre (9.2 lbs/1000 ft²). When vegetation has emerged to a stand and is growing, 30 to 40 lbs (0.8 lb/1000 ft²) of additional nitrogen fertilizer should be applied.

Legume alone: 0-20-20 or equivalent-500 lbs/acre (11.5 lbs/1000 ft²).

Incorporate lime and fertilizer to a minimum depth of at least 6" or more by disking or chiseling on slopes of up to 3:1.

Planting

Select adapted species from Figure FS-1 and Table FS-1.

Apply seed uniformly using a cyclone seeder, drill seeder, cultipacker seeder or hydroseeder.

When using a drill seeder, plant grasses and legumes ¼" to ½" deep. Calibrate equipment in the field.

When planting by methods other than a drill seeder or hydroseeder, cover seed by raking, or dragging a chain, brush, or mat. Then firm the soil lightly with a roller. Seed can also be covered with hydro-mulched wood fiber and tackifier. Legumes

require inoculation with nitrogen-fixing bacteria to ensure good growth. Purchase inoculum specific for the seed and mix with seed prior to planting.

Table FS-1 Commonly Used Plants for Permanent Cover¹

Species	Seeding Rates/Ac PLS ²	North	Central	South
		Seeding Dates		
Bahiagrass, Pensacola	40 lbs	--	Mar 1-July 1	Feb 1-Nov 1 ³
Bermudagrass, Common	10 lbs	Apr 1-July 1	Mar 15-July 15	Mar 1-July 15
Bahiagrass, Pensacola Bermudagrass, Common	30 lbs 5 lbs	--	Mar 1-July 1	Mar 1-July 15
Bermudagrass, Hybrid (Lawn Types)	Solid Sod	Anytime	Anytime	Anytime
Bermudagrass, Hybrid (Lawn Types)	Sprigs 1/sq ft	Mar 1-Aug 1	Mar 1-Aug 1	Feb 15 - Sep 1
Fescue, Tall	40-50 lbs	Sep 1-Nov 1	Sep 1-Nov 1	--
Sericea	40-60 lbs	Mar 15-July 15	Mar 1-July 15	Feb 15 -July 15
Sericea & Common Bermudagrass	40 lbs 10 lbs	Mar 15 -July 15	Mar 1-July 15	Feb 15-July 15
Switchgrass, Alamo	4 lbs	Apr 1-Jun 15	Mar 15-Jun 15	Mar 15-Jun 15

- 1 DO NOT USE Seeding Rates as part of a mixture unless shown as a mixture in this table.
- 2 PLS means Pure Live Seed and is used to adjust seeding rates. For example, to plant 10 lbs PLS of a species with germination of 80% and purity of 90%, PLS= 0.8 X 0.9 = 72%. 10lbs PLS = 10/0.72 = 13.9 lbs of the species to be planted.
- 3 A late fall planting of Bahiagrass should include 45 lbs./ac. of small grain to provide cover during winter months.

Mulching

Cover approximately 75% of the surface with the specified mulch materials. Crimp, tack or tie down straw mulch with netting. Mulching is extremely important for successful seeding (See Mulching practice for more details).

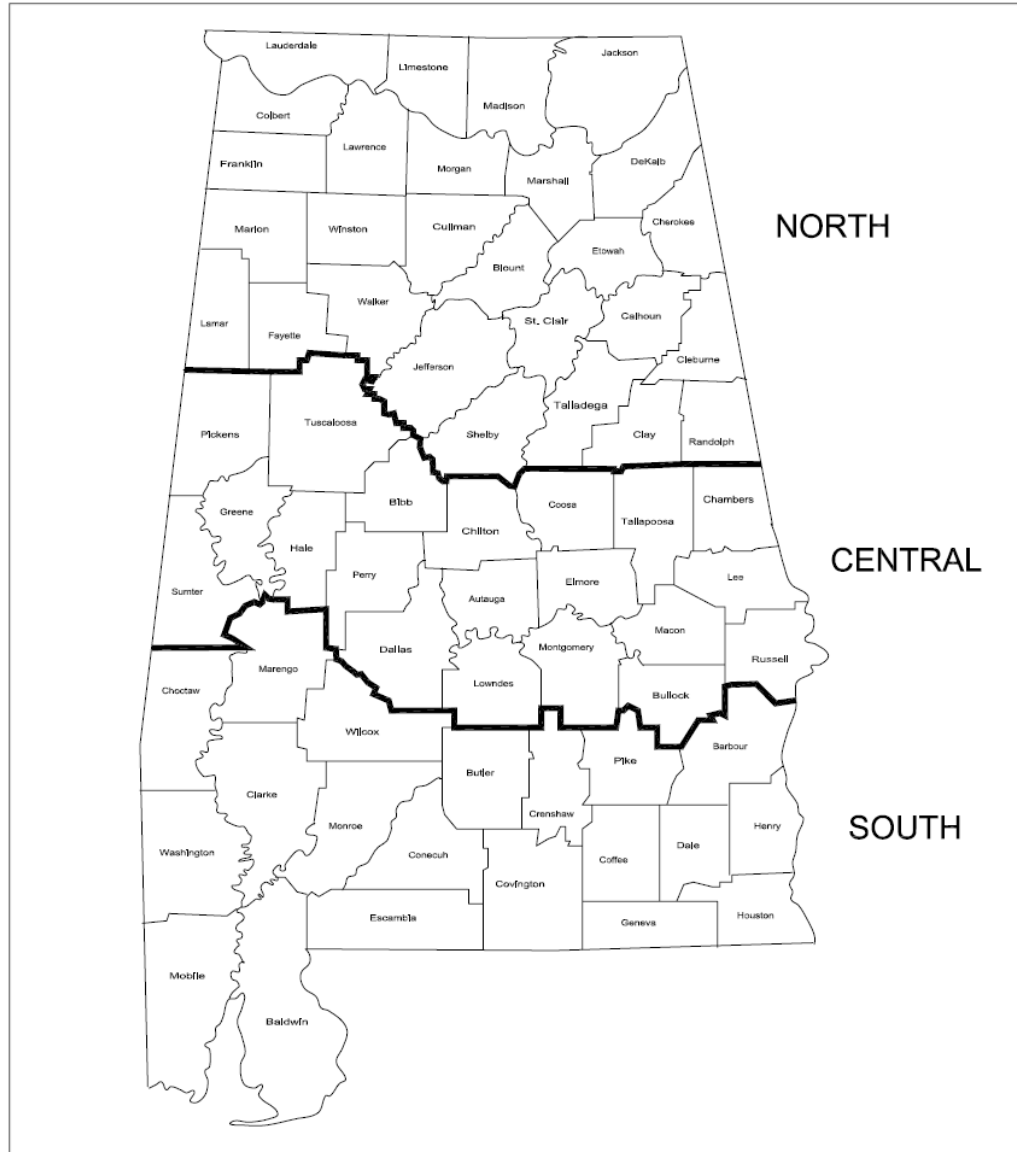

Figure FS-1 Geographical Areas for Species Adaptation and Seeding Dates

Note: Site conditions related to soils and aspect in counties adjacent or close to county boundaries may justify adjustments in planting dates by qualified design professionals.

This Page Intentionally Left Blank

Floating Turbidity Barrier (FB)



Practice Description

A floating turbidity barrier consists of geotextile material (curtain) with floats on the top, weights on the bottom, and an anchorage system that minimizes sediment transport from a disturbed area that is adjacent to or within a body of water. The barrier provides sedimentation and turbidity protection for a watercourse from up-slope land disturbance activities where conventional erosion and sediment controls cannot be used or need supplemental sediment control, or from dredging or filling operations within a watercourse. The practice can be used in non-tidal and tidal watercourses where intrusion into the watercourse by construction activities has been permitted and subsequent sediment movement is unavoidable.

Planning Considerations

Soil loss into a watercourse results in long-term suspension of sediment. In time, the suspended sediment may travel long distances and affect widespread areas. A turbidity barrier is designed to deflect and contain sediment within a limited area and provide enough residence time so that soil particles will fall out of suspension and not travel to other areas.

Turbidity barrier types must be selected based on the flow conditions within the waterbody, whether it is a flowing channel, lake, pond, or a tidal watercourse. The specifications contained within this practice pertain to minimal and moderate flow conditions where the velocity of flow may reach 5 ft/sec (or a current of approximately 3 knots). For situations where there are greater flow velocities or

currents, a qualified design professional and product manufacturer should be consulted.

Consideration must also be given to the direction of water movement in channel flow situations. Turbidity barriers are not designed to act as water impoundment dams and cannot be expected to stop the flow of a significant volume of water. They are designed and installed to trap sediment, not to halt the movement of water itself. In most situations, turbidity barriers should not be installed across channel flows. There is an exception to this rule. This occurs when there is a danger of creating a sediment buildup in the middle of a watercourse, thereby blocking access or creating a sediment bar. Curtains have been used effectively in large areas of moving water by forming a very long-sided, sharp “V” to deflect clean water around a work site, confining a large part of the sediment-laden water to the work area inside the “V” and direct much of the sediment toward the shoreline. Care must be taken, however, not to install the curtain perpendicular to the water current.

In tidal or moving water conditions, provisions must be made to allow the volume of water contained within the barrier to change. Since the bottom of the barrier is weighted and external anchors are frequently added, the volume of water contained within the curtain will be much greater at high tide versus low tide and measures must be taken to prevent the curtain from submerging. In addition to allowing slack in the curtain to rise and fall, water must be allowed to flow through the curtain if the curtain is to remain in roughly the same place and maintain the same shape. Normally, this is achieved by constructing part of the curtain from a heavy woven filter fabric. The fabric allows the water to pass through the curtain, but retains the sediment particles. Consideration should be given to the volume of water that must pass through the fabric and sediment particle size when specifying fabric permeability.

Sediment, which has been deflected and settled out by the curtain, may be removed if so directed by the on-site inspector or the permitting agency. However, consideration must be given to the probable outcome of the procedure, which may create more of a sediment problem by resuspension of particles and by accidental dumping of the material by the equipment involved. It is, therefore, recommended that the soil particles trapped by a turbidity curtain only be removed if there has been a significant change in the original contours of the affected area in the watercourse. Regardless of the decision made, soil particles should always be allowed to settle for a minimum of 6-12 hours before removal by equipment or before removal of a turbidity curtain.

It is imperative that all measures in the erosion control plan be used to keep sediment out of the watercourse. However, when proximity to the watercourse makes successfully mitigating sediment loss impossible, the use of the turbidity curtain during land disturbance is essential.

Design Criteria

Floating turbidity barriers are normally classified into 3 types:

- Type I (see Figure FB-1) is used in protected areas where there is no current and the area is sheltered from wind and waves.
- Type II (see Figure FB-1) is used in areas where there may be small to moderate current (up to 2 knots or 3.5 ft/sec) and/or wind and wave action can affect the curtain.
- Type III (see Figure FB-2) is used in areas where considerable current (up to 3 knots or 5 ft/sec) may be present, where tidal action may be present, and/or where the curtain is potentially subject to wind and wave action.

Turbidity curtains should extend the entire depth of the watercourse whenever the watercourse in question is not subject to tidal action and/or significant wind and wave forces. This prevents sediment-laden water from escaping under the barrier, scouring, and resuspending additional sediments.

In tidal and/or wind and wave action situations, the curtain should never be so long as to touch the bottom. A minimum 1-foot gap should exist between the weighted, lower end of the skirt and the bottom at “mean” low water. Movement of the lower skirt over the bottom due to tidal reverses or wind and wave action on the flotation system may fan and stir sediments already settled out.

In tidal and/or wind and wave action situations, it is seldom practical to extend a turbidity curtain depth lower than 10 to 12 feet below the surface, even in deep water. Curtains which are installed deeper than this will be subjected to very large loads with consequent strain on curtain materials and the mooring system. In addition, a curtain installed in such a manner can “billow up” toward the surface under the pressure of the moving water, which will result in an effective depth which is significantly less than the skirt depth.

Turbidity curtains should be located parallel to the direction of flow of a moving body of water. Turbidity curtains should not be placed across the main flow of a significant body of moving water.

When sizing the length of the floating curtain, allow an additional 10-20% variance in the straight-line measurements. This will allow for measuring errors, make installing easier and reduce stress from potential wave action during high winds.

An attempt should be made to avoid an excessive number of joints in the curtain. A minimum continuous span of 50 feet between joints is a good “rule of thumb.”

For stability reasons, a maximum span of 100 feet between anchor or stake locations is also a good rule to follow.

The ends of the curtain, both floating upper and weighted lower, should extend well up onto the shoreline, especially if high water conditions are expected. The

ends should be secured firmly to the shoreline to fully enclose the area where sediment may enter the water.

When there is a specific need to extend the curtain to the bottom of the watercourse in tidal or moving water conditions, a heavy woven pervious filter fabric may be substituted for the normally recommended impervious geotextile. This creates a “flow-through” medium, which significantly reduces the pressure on the curtain and will help to keep it in the same relative location and shape during the rise and fall of tidal waters.

Typical installation layouts of turbidity curtains can be seen in Figure FB-3. The number and spacing of external anchors will vary depending on current velocities and potential wind and wave action. Manufacturer’s recommendations should be followed.

In navigable waters, additional permits may be required from the Corps of Engineers or other regulatory agencies if the barrier creates an obstruction to navigation.

Materials and Installation Requirements

Barriers should be a bright color (yellow or “international” orange) that will attract the attention of nearby boaters. The curtain fabric must meet the minimum requirements noted in Table FB-1.

Seams in the fabric should be either vulcanized welded or sewn, and should develop the full strength of the fabric.

Flotation devices should be flexible, buoyant units contained in an individual flotation sleeve or collar attached to the curtain. Buoyancy provided by the flotation units should be sufficient to support the weight of the curtain and maintain a freeboard of at least 3” above the water surface level.

Load lines must be fabricated into the bottom of all floating turbidity curtains. Type II and Type III curtains must have load lines also fabricated into the top of the fabric. The top load line should consist of woven webbing or vinyl-sheathed steel cable and should have break strength in excess of 10,000 pounds (5 t). The supplemental (bottom) load line should consist of a chain incorporated into the bottom hem of the curtain of sufficient weight to serve as ballast to hold the curtain in a vertical position. Additional anchorage should be provided as necessary. The load lines should have suitable connecting devices which develop the full breaking strength for connecting to load lines in adjacent sections (See Figures FB-1 and FB-2 which portray this orientation)

Table FB-1 Curtain Fabric Material Requirements for Floating Turbidity Barriers

Characteristic Test Method	16 Oz Nominal Laminated	18 Oz Laminated	22 Oz Coated	Geotextile Filter
Construction	Vinyl Laminate On 1300 Denier 9 X 9 Scrim	Vinyl Laminate On1300 Denier 9 X 9 Scrim	Vinyl Coated On Woven 6 Oz Polyester Base	Woven Polypropylene
Weight Astm D-751-95 Sec 16	Nominal 16 Oz/Sq Yd 376 Gr/Sq M	18 Oz/Sq Yd 423 Gr/Sq M	22 Oz/Sq Yd 517 Gr/Sq M	7.5 Oz/Sq Yd 176 Gr/Sq M
Adhesion Astm D-751-95 Sec 43.1.2	15 Lb/In 14 Dan/5 Cm	15 Lb/In 14 Dan/5 Cm	14 Lb/In 13 Dan/5 Cm	Not Applicable
Tensile Strength Astm D-751-95 Sec 12	324 X 271 Lb/In 308 X 258 Dan/5 Cm	397 X 373 Lb/In 378 X 363 Dan/5 Cm	500 X 400 Lb/In 476 X 389 Dan / 5 Cm	350 X 250 Lb/ In 333 X 230 Dan / 5 Cm
Tear Strength Astm D-751-95 Sec 29	76 X 104 Lb/In 72 X 99 Dan/5 Cm	96 X 86 Lb/In 91 X 82 Dan/5 CM	132 X 143 Lb/In 126 X 136 Dan / 5 Cm	95 X 55 Lb/In 90 X 52 Dan / 5 Cm
Hydrostatic Astm D-751-95 Sec 34.2	385 Lb/Sq In 2674 Kpa	385 Lb/Sq In 674 Kpa	881 Lb/Sq In 6118 Kpa	Not Applicable

External anchors may consist of 2" x 4" or 2½" minimum diameter wooden stakes, or 1.33 pounds/linear foot steel posts when Type I installation is used. When Type II or Type III installations are used, bottom anchors should be used.

Bottom anchors must be sufficient to hold the curtain in the same position relative to the bottom of the watercourse without interfering with the action of the curtain. The anchor may dig into the bottom (grappling hook, plow or fluke-type) or may be weighted (mushroom type) and should be attached to a floating anchor buoy via an anchor line. The anchor line would then run from the buoy to the top load line of the curtain. When used with Type III installations, these lines must contain enough slack to allow the buoy and curtain to float freely with tidal changes without pulling the buoy or curtain down and must be checked regularly to make sure they do not become entangled with debris. As previously noted, anchor spacing will vary with current velocity and expected wind and wave action. Manufacturer's recommendations should be followed. See orientation of external anchors and anchor buoys for tidal installation in Figure FB-2.

Installing 2 parallel curtains, separated at regular intervals by 10 feet long wooden boards or lengths of pipe can increase the effectiveness of the barrier.

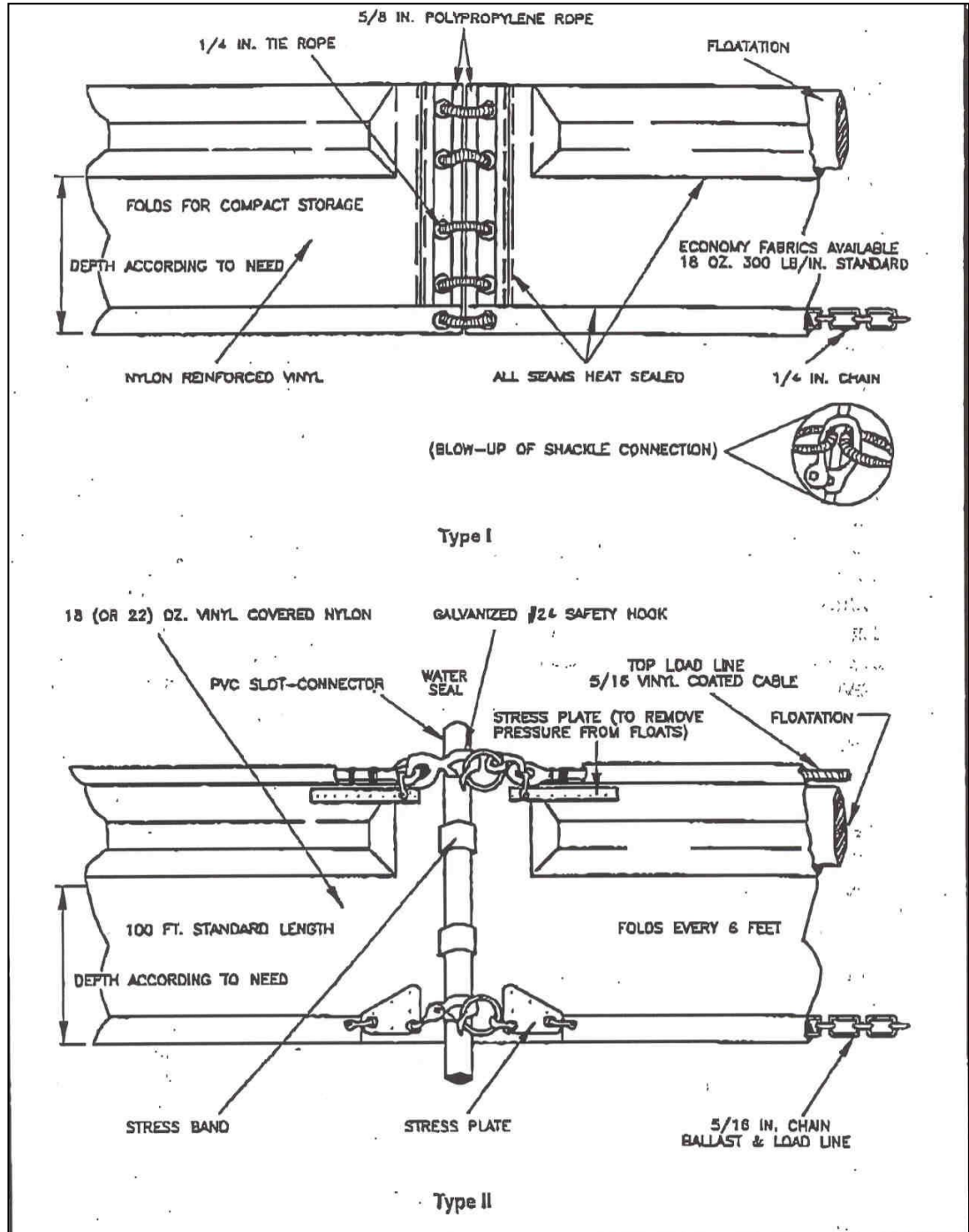

Figure FB-1 Type I and II Floating Turbidity Barriers
 (Source: American Boom and Barrier Corp. product literature)

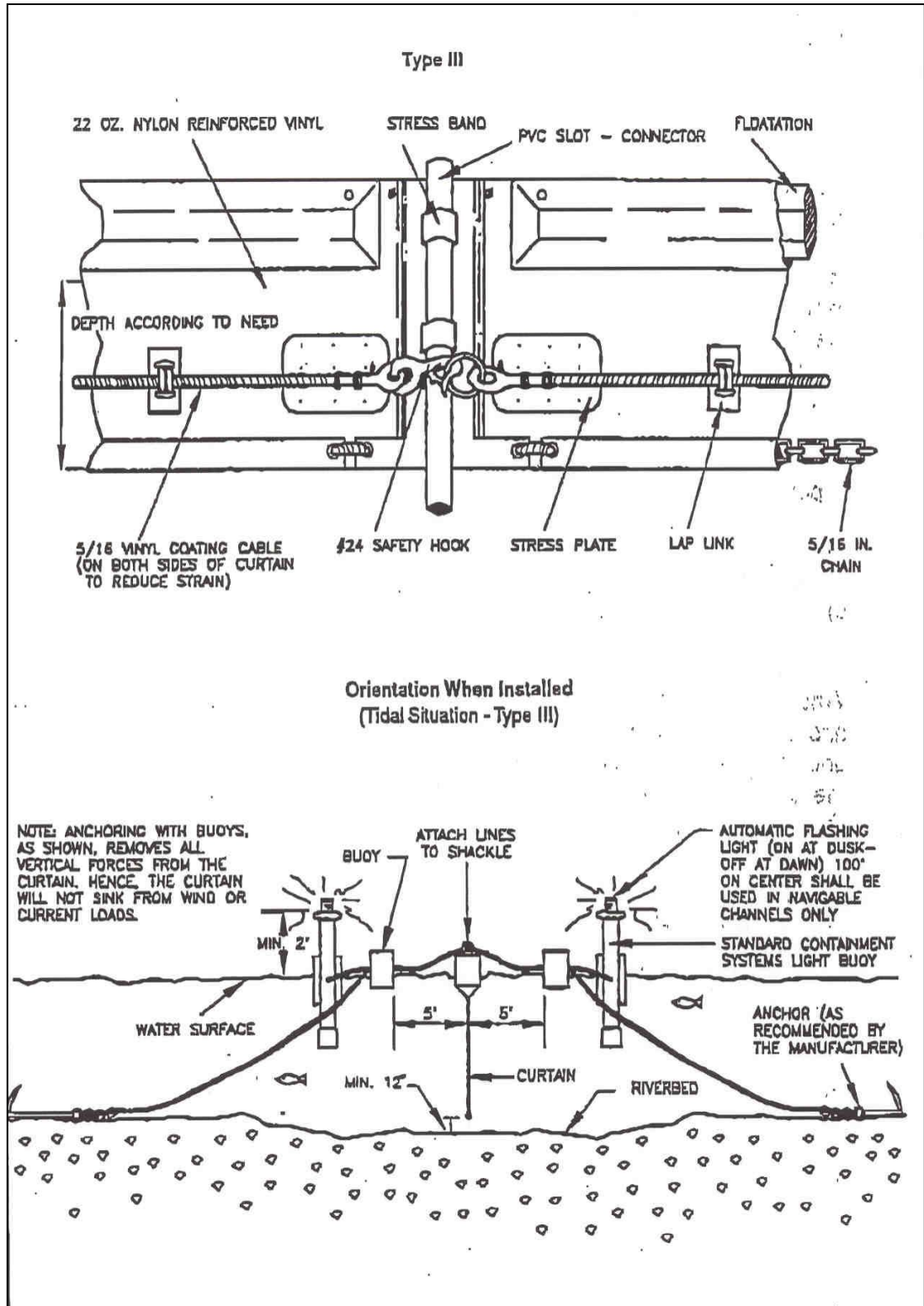

Figure FB-2 Type III Floating Turbidity Barrier
 (Source: American Boom and Barrier Corp. product literature)

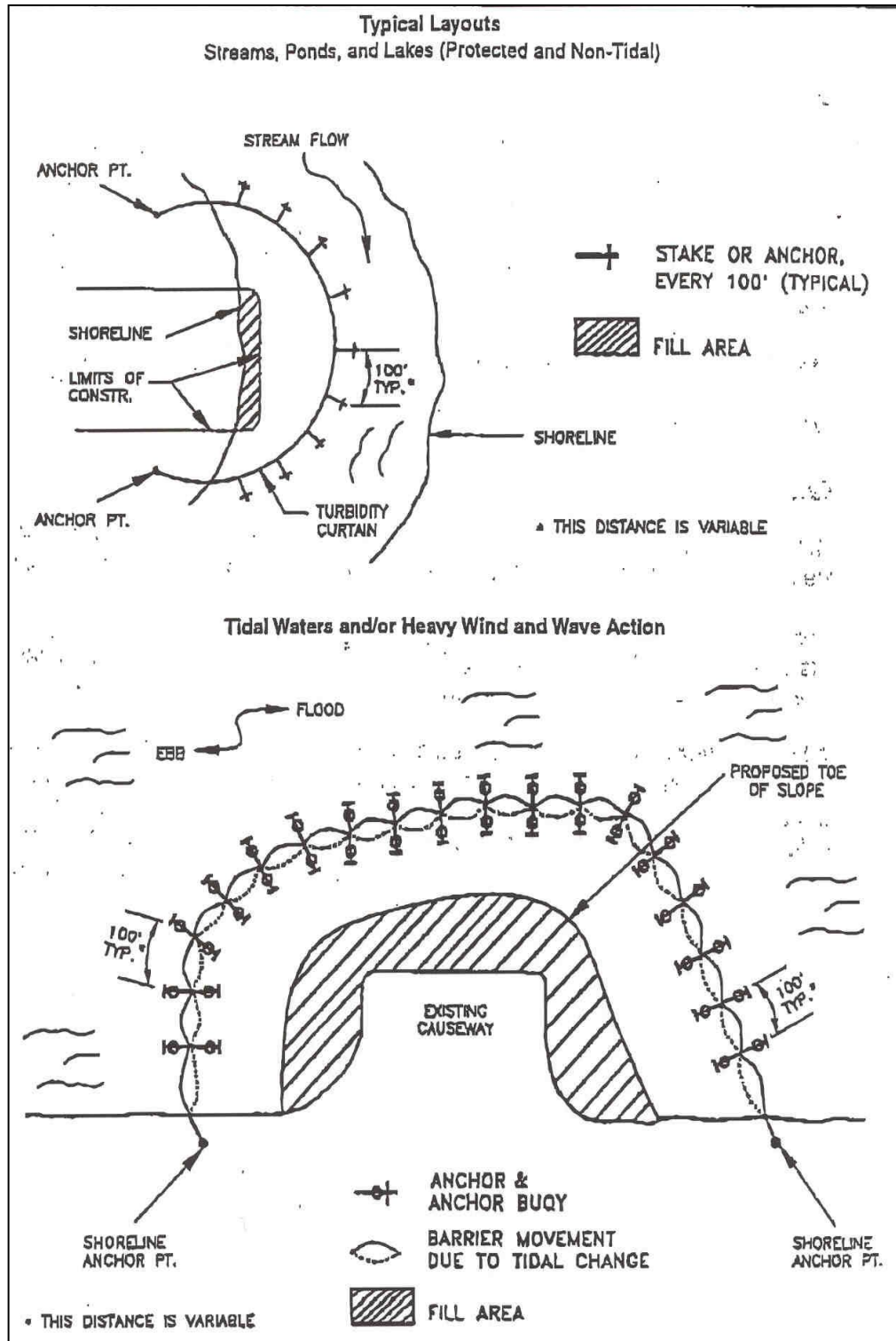

Figure FB-3 Typical Installation Layouts
(Source Florida Department of Transportation Road and Design Specifications)

Flocculant (FL)



Practice Description

A Flocculant is a chemical that facilitates the aggregation of fine suspended soil particles to produce large flocs that can quickly settle out of suspension. Flocculants are often used to help polish or minimize turbidity of stormwater runoff from construction sites.

Planning Considerations

Products containing polyacrylamide (PAM) are commonly used in construction. PAM is a term describing a wide variety of chemicals based on the acrylamide unit. Products containing chitosan have also shown to be effective in reducing turbidity in stormwater runoff and are also commonly used in the US. Chitosan is a naturally occurring polymer.

When properly applied at the recommended rates, flocculants can be used as polishing agents to remove sediments from turbid runoff water on a construction site. If conventional erosion and sediment control are not being properly implemented to the fullest extent, flocculants will have little or no effect on the quality of the runoff from a construction site. Most flocculant products are available in emulsions, powders, gel bars, logs, tablets, and socks.

When including flocculant as a treatment option on a project, the following items must be addressed:

- Some state regulatory agencies do not allow the use of flocculants for turbidity management. Flocculants are allowed in Alabama.
- Flocculant products should be tested for ecotoxicity and proven to not be toxic if used in accordance with the manufacturer's recommended application rates.
- Material Safety Data Sheets (MSDS) should be stored and available onsite.
- Areas where flocculant is applied must drain to a sediment basin or other BMP that promotes settling for final flocculation prior to discharging from the site.
- Adequate mixing is necessary for flocculant to be fully effective. Passive treatment using the turbulent flow of water in a channel or at the outlet of a pipe as the mixing method is encouraged.
- Adequate time and laminar flow (calm flow) or ponding is necessary to promote effective and efficient flocculation.
- Flocculant must be reapplied as it becomes bound with sediment particles with each rain event or other new flow.
- Flocculants that are water soluble dissolve slowly and may require considerable agitation and time to dissolve.
- Soil tests, such as the "jar test", are required to ensure that the flocculant is properly matched with the anticipated soils suspended in the runoff.
- Manufacturers or project specific application or dosage rates and application instructions should be followed closely based on specific site conditions and soils.

A rather recent flocculant delivery method sometimes referred to as a "turbidity reduction barrier" is used to reduce turbidity in runoff that reach sensitive sites. The measure consists of a double row of netting that allows runoff to easily pass through and contains loose straw spread between the rows. The netting should be a high-flow non-blinding fabric. Material such as jute is laid on the ground underneath the loose straw and adjacent to the downslope row (see Figure FL-1). An approved flocculant powder is added to the straw in layers between the netting and to the jute under the straw and below the downslope row prior to runoff events. The measure is located upstream of a filter strip or buffer zone with the intent of capturing flocs prior to discharging offsite. A turbidity reduction barrier is installed on the contour and should be located directly downstream of another sediment barrier that is intended to capture the large sediment particles. The turbidity reduction barrier provides minimal impoundment and should be used only as a means to the reduce turbidity of the stormwater runoff. Design professionals should get details needed to design this measure from a qualified industry representative.

Turbidity reduction barriers (Figure FL-1) may be used as a "last line of defense" against sediment leaving the construction site in sensitive areas if there is a filter strip or buffer zone directly downstream of the practice. It is recommended that turbidity reduction barriers be used in conjunction with appropriate erosion and sediment control practices and should not be used alone. Turbidity reduction barriers are intended to further treat sediment-laden water containing fine

suspended particles prior to offsite discharge. This practice is not intended to capture large sediment particles that will easily fall out of suspension.



Figure FL-1 Turbidity Reduction Barrier

Design Criteria

Flocculants mixed with turbid water and allowed adequate settling time can greatly reduce turbidity and suspended solids concentrations. Flocculants are commonly used to passively treat construction stormwater runoff in a conveyance, within sediment basins, or with other sediment traps, barriers, or other practices. Flocculants may also be used in conjunction with erosion control practices and products to better manage raindrop and rill erosion. Flocculant is also used as a part of active treatment systems. It is critical that precautions are taken to minimize the potential for over application of flocculant or the release of flocs into receiving waters.

The following basic guidelines, at a minimum, should be followed when specifying or using flocculant:

1. Completely understand any regulatory requirements concerning the use of flocculants.
2. Choose the appropriate flocculant for the soil type.
3. Choose flocculants deemed non-toxic based on toxicity reports related to the planned use.
4. Adhere to manufacturer or project specific recommendations and MSDS for specification and application.
5. Use flocculants in conjunction with other appropriate BMPs. Pretreatment to remove heavy loads and larger particles should take place in advance of flocculant introduction when possible.
6. Do not apply flocculants directly to streams, wetlands, or other waters of the state.

7. Provide provisions for capturing flocs prior to their entering receiving waters.
8. Use of multiple types of flocculants in the same watershed should be avoided. Without a full understanding of the chemical interactions of each flocculant there is a possibility the two flocculants could interact with each other, reducing the overall effectiveness.
9. Dry form (powder) may be applied by hand spreader or mechanical spreader. Mixing with dry silica sand will aid in spreading. Pre-mixing of dry form flocculants into fertilizer, seed or other soil amendments is allowable.
10. Solid forms of flocculant shall be applied following site testing results to ensure proper placement and performance and shall meet or exceed state and federal water quality requirements. Logs, blocks, and tablets must be installed up gradient from the sediment capture BMP. Solid forms of flocculant should be protected from the sun and remain hydrated if possible.
11. Some flocculants involve a two-component system and generally are provided in the form of “socks.” Manufacturer recommendations for installation and matching the components should be followed closely.

Materials and Installation Requirements

One of the key factors in making a flocculant work is to ensure that it is dissolved and thoroughly mixed with the runoff water, which can be accomplished in several ways. Introducing the flocculant to the runoff at a point of high velocity will help to provide the turbulence and mixing needed to maximize the suspended sediment exposure to the flocculant. Examples include a storm drain junction box where a pipe is dropping water, inside a slope drain, or other areas of falling or fast-moving water upslope from a sediment capture BMP.

Another option for introducing flocculant into runoff involves running the water over a solid form of flocculant. Powders can be sprinkled on various practices such as check dams and materials, such as jute, coir, or other geotextiles. When wet, flocculants could become very sticky, and bind to the geotextile fabric. The product binds to the material, and resists removal by flowing water rendering it ineffective for turbidity control.

Flocculant logs are designed to be placed in flowing water to dissolve the flocculant from the log somewhat proportionately to flow. While using these solid forms does not have the same challenges as liquid forms, they do have drawbacks. The amount of flocculant released is not adjustable and is generally unknown, so the user should adjust the system by moving or adding logs to get the desired effect. Because flocculant blocks can be sticky when wet, it can accumulate materials from the runoff and become coated, releasing little flocculant. The solid forms also tend to harden when allowed to dry. This causes less flocculant to be released initially during the next storm until the log becomes moist again.

To avoid these problems, the user must do two things to ensure flocculant releases from the solid form:

- Reduce sediment load in the runoff upstream of the flocculant location. This avoids burying the flocculant under accumulated sediment.
- Create constant flow across or onto the solid flocculant. The flow will help dissolve and mix the flocculant as well as prevent suspended solids from sticking to the product.

This Page Intentionally Left Blank

Inlet Protection (IP)



Practice Description

Inlet protection is a temporary practice installed around, above, or within a storm drain to minimize the conveyance of sediment. This practice applies where early use of the storm drain system is necessary prior to stabilization of the disturbed drainage area.

Planning Considerations

Storm sewers which are made operational before their drainage area is stabilized can convey large amounts of sediment to natural drainage ways. In case of extreme sediment loading, the storm sewer itself may clog and lose a major portion of its capacity. To avoid these problems, it is necessary to prevent sediment from entering the system at the inlets which may discharge directly to waters of the State.

The best way to prevent sediment from entering the storm sewer system is to stabilize the site as quickly as possible, preventing erosion and stopping sediment at its source. Sediment is best treated by preventing erosion. Leave as much of the site undisturbed as possible in the total site plan by phasing construction. Clear and disturb the site in small increments, if possible.

This practice is suitable for inlets with a drainage area of less than 1 acre. Gentler approach slopes provide for more storage. If used at a storm drain for a road, the practice could cause hazardous conditions to motorists due to ponding and should only be used when there is no public transportation allowed or when the height of ponded water is not a hazard.

Numerous products have been developed to facilitate the capture of suspended soil particles at inlets. The Design Criteria for performance should be considered when evaluating alternative products. Products that will likely not meet performance goals or that usually fail under storm conditions should not be selected.

Recommended installation procedures of the Auburn University Stormwater Research Facility should be followed to ensure the inlet protection practice is to be most successful. The Alabama Department of Transportation has developed drawings and specifications for many of these type installations.

Silt Fence Inlet Protection

As a minimum, incorporate the following into a silt fence inlet protection practice at a stormwater drop inlet:

- Use geotextile (8 oz. non-woven) as an underlayment on the compacted earth surface from the inlet to at least 1 ft. beyond the silt fence. The geotextile must be securely pinned at 5-inch centers at the inlet and around the outside edge of the geotextile.
- Use steel T-posts on maximum 3 ft. centers around the inlet.
- Do not trench the silt fence. Install the wire backing tightly from the compacted earth surface to the top of the posts, and secure to the posts.
- Add 2 x 4 bracing at the top of the posts and diagonally across the corners. Drill holes to fit over T-posts once T-posts are installed to ensure a proper fit.
- Install a dewatering device to remove water from the impoundment within 48 hours. A 2 x 4 vertical board with graduated holes (smallest at bottom and largest at top) has been found to work well. The fabric should be secured to the board with staples and the geotextile punctured at each hole.
- Install the geotextile (4 oz. non-woven) Type A silt fence. The top of the geotextile shall be folded over the 2 x 4 bracing and stapled. The bottom of the geotextile shall extend about 8 inches horizontally from the bottom of the fence and secured with pins every 5 inches. The bottom of the fabric at the corners shall be cut and pinned securely to prevent water undermining. Attach the geotextile to the wire as normally done for a silt fence.



Figure IP-1 Silt Fence Inlet Protection Installation. (Showing geotextile underlayment, steel T-posts, 2 x 4 bracing, and dewatering device.)
(Photo courtesy of AU-SRF. See Appendix for CAD files)



Figure IP-2 Silt Fence Inlet Protection Installation. (Showing silt fence, geotextile underlayment, steel T-posts, 2 x 4 bracing, and dewatering device.)
(Photo courtesy of AU-SRF. See Appendix for CAD files)

Block and Gravel Inlet Protection

As a minimum, incorporate the following into a block and gravel inlet protection practice at a stormwater drop inlet:

- Use geotextile (8 oz. non-woven) as an underlayment on the compacted earth surface that extends from the inlet, under the blocks and at least 1 ft. beyond the blocks, and securely pinned at 5 inches centers at the inlet and around the outside edge of the geotextile. A second underlay that extends from the inlet, under the blocks, and to the top of the blocks between the blocks and gravel. Note: place geotextile vertically on the blocks surface after blocks and hardware cloth are installed.
- Use 8-inch cinder blocks no more than two blocks high. Stacked the second layer of blocks in a staggered fashion. All blocks are placed in a normal orientation with at least one block turned sideways for dewatering.
- The dewatering block(s) shall be at the lowest elevation, faced with hardware cloth, and the geotextile cut out in a three-inch-tall rectangular section for dewatering.
- Place aggregate (ALDOT no. 4 stone) in a triangular cross-section to the top of the blocks with the aggregate extending out 1 ft. at the top from the blocks before sloping down at a 1:1 ft./ft. slope.



Figure IP-3 Block and Gravel Inlet Protection Installation.
(Showing geotextile underlayment, gravel, and dewatering device.)

(Photo courtesy of AU-SRF. See Appendix for CAD files)



Figure IP-4 Block and Gravel Inlet Protection Installation.
(Showing dewatering device.)
(Photo courtesy of AU-SRF. See Appendix for CAD files)

Sand Bag Inlet Protection

As a minimum, incorporate the following into a sand bag inlet protection practice at a stormwater drop inlet:

- Use geotextile (8 oz. non-woven) as an underlayment on the compacted earth surface that extends from the inlet to at least 1 ft. beyond the sand bags. Pin the geotextile securely at the inlet and around the edges on 5-inch centers.
- Place sand bags tight against each other around an inlet in a circular fashion with at least a 1 ft. space between the bags and the inlet.
- Orient the three layers of bags into a triangular cross-section with the first layer consisting of two bags oriented tangent to the circle, the second layer consisting of one bag perpendicular to the circle, and the third layer consisting of one bag tangent to the circle.



Figure IP-5 Sand Bag Inlet Protection Installation.
(Photo courtesy of AU-SRF. See Appendix for CAD files)

Wattle Inlet Protection

As a minimum, incorporate the following into a wattle inlet protection practice at a stormwater drop inlet:

- Use geotextile (8 oz. non-woven) as an underlayment on the compacted earth surface that extends from the inlet to at least 1 ft. beyond the wattles. Pin the geotextile securely at the inlet and around the edges on 5-inch centers.
- Use a wattle that is denser and less porous to ensure ponding occurs.
- Place the wattle in a circular fashion at least 1 ft. from the inlet. Wattle ends should be overlapped at least 18 inches and secured with grade stakes or hardwood stakes a T-Pee or A-Frame type installation method.
- Stake the wattles with T-Pee stakes at least 2 ft. on centers.
- Prevent the wattles from floating by securing with sod staples on each side of the wattle on approximately 6-inch centers.



Figure IP-6 Wattle Inlet Protection Installation.

(Photo courtesy of AU-SRF. See Appendix for CAD files)

Manufactured Inlet Protection

As a minimum, ensure that the manufactured inlet protection device accomplishes the following:

- Is structurally supported to withstand sediment and hydrostatic loads.
- Ponds water to allow for coarse sediment to settle out of suspension.
- Does not float or undermine.
- Does not cause erosion of the soil surface between the device and the inlet.
- Has a dewatering mechanism to prevent prolonged flooding.

Design Criteria

Drainage Area

Drainage area should be less than 1 acre per inlet.

Height

The height of the inlet protection device should be at least 1 foot but no more than 2.5 foot. Ensure the height of the structure when fully ponded does not cause unintentional damage or hazards to adjacent areas.

Approach

A gentle approach to the inlet protection provides more storage.

Sediment Storage

Maximizing storage increases ponding and sediment deposition. Whenever possible, either through structure height and/or excavated storage, provide 67 cubic yards per disturbed acre for sediment storage. This will provide sediment storage for ½ inch runoff from the disturbed area. For example, if the disturbed area is 0.3 acre, provide 20 cubic yards of storage ($0.3 \times 67 = 20$).

Structural Frame

The inlet protection device should be designed to withstand sediment and hydrostatic loads without failure due to buckling, fabric sagging, or undermining.

Performance

The inlet protection device should be designed to trap most of the coarse sediment. Turbidity is not controlled by the inlet protection practice. The system of protection for the project must be designed to meet the NTU requirements for discharge.

Maintenance

When sediment has accumulated to ½ the height of the structure, it should be removed and disposed of properly.

Safety

Protection should be provided to prevent children from entering open-top structures. Do not use the practice if it ponds water on roads used by motorist.

Rock Filter Dam (RD)



Practice Description

A rock filter dam is a stone embankment designed to help capture sediment in natural or constructed drainageways on construction sites. This practice can be used as a forebay to a sediment basin to help capture coarser particles of sediment.

Planning Considerations

Rock filter dams are used across drainageways to help remove coarser sediment particles and reduce off-site sediment delivery. Since rock filter dams are installed in flowing water, all local, state, and federal laws and regulations must be followed during the design and construction process. It is usually located so that it intercepts runoff primarily from disturbed areas, is accessible for periodic sediment removal and does not interfere with construction activities.

Dams should be designed so that impounded water behind the structures will not encroach on adjoining property owners or on other sediment and erosion control measures that outlet into the impoundment area.

Dams should be located so that the basin intercepts runoff primarily from disturbed areas, has adequate storage, and so that the basin can be accessed for sediment removal. Dams should also be located, as much as possible, in areas that do not interfere with construction activities.

Rock filter dams are not permanent structures. The design life of the structure is 3 years or less.

Design Criteria

Drainage Area

The drainage area above the dam should not exceed 10 acres.

Dam Height

The height of dam will be limited by the channel bank height or 8 feet, whichever is less. The dam height should also not exceed the elevation of the upstream property line. Water will bypass over the top of the dam and the back slope of the rock dam should be designed to be stable.

Spillway Capacity

The top of the dam should be designed to handle the peak runoff from a 10-year, 24-hour design storm with a maximum flow depth of 1 foot and freeboard of 1 foot. Therefore, the center portion of the dam should be at least 2 feet lower than the outer edges at the abutment. See Figure RD-1.

Dam Top Width

The minimum top width should be 6 feet. See Figure RD-2.

Dam Side Slopes

Side slopes should be 3:1 or flatter on the back slope and 2.5:1 or flatter on the front slope.

Outlet Protection

The downstream toe of the dam should be protected from erosion by placing larger stone on the back slope and a riprap apron at the toe. The apron should be placed on a zero grade with a riprap thickness of 1.5 feet. The apron should have a length equal to the height of the dam as a minimum and longer if needed to protect the toe of the dam.

Location

The dam should be located as close to the source of sediment as possible so that it will not cause water to back up onto adjoining property.

Basin Requirements

The basin behind the dam should provide a surface area that maximizes the sediment trapping efficiency. The basin should have a sediment storage capacity of 67 cubic yards per acre of drainage area.

Riprap Requirements

Stone for riprap should consist of field stone or rough unhewn quarry stone of approximately rectangular shape. The stone should be hard and angular and of such quality that it will not disintegrate on exposure to water or weathering and it should be suitable in all other respects for the purpose intended. The specific gravity of the individual stones should be at least 2.5.

The minimum median stone size should be 9". The gradation of rock to be used should be specified using Tables RD-1 and RD-2. Table RD-1 is used to determine the weight of the median stone size (d50). Using this median weight, a gradation can be selected from Table RD-2, which shows the commercially available riprap gradations as classified by the Alabama Department of Transportation.

The dam should be faced with 1 foot of smaller stone ($\frac{1}{2}$ " to $\frac{3}{4}$ " gravel) on the upstream side to increase efficiency for trapping coarser particles. Geotextile can also be added between the smaller stone and rock.

Table RD-1 Size of Riprap Stones

Weight (lbs)	Mean Spherical Diameter (ft)	Rectangular Shape	
		Length (ft)	Width, Height (ft)
50	0.8	1.4	0.5
100	1.1	1.75	0.6
150	1.3	2.0	0.67
300	1.6	2.6	0.9
500	1.9	3.0	1.0
1000	2.2	3.7	1.25
1500	2.6	4.7	1.5
2000	2.75	5.4	1.8
4000	3.6	6.0	2.0
6000	4.0	6.9	2.3
8000	4.5	7.6	2.5
20000	6.1	10.0	3.3

Geotextiles

Non-woven geotextiles should be used as a separator between the graded stone, the soil base, and the abutments. The geotextile shall be of the strength and durability required for the project to ensure the rock and soil base are stable. Generally, the non-woven geotextile should meet the requirements found in AASHTO M288 for Class 2 geotextile used for

separation. Geotextile should be placed immediately adjacent to the subgrade without any voids between the fabric and the subgrade.

Table RD-2 Graded Riprap

Class	Weight (lbs)					
	d ₁₀	d ₁₅	d ₂₅	d ₅₀	d ₇₅	d ₉₀
1	10	-	-	50	-	100
2	10	-	-	80	-	200
3	-	25	-	200	-	500
4	-	-	50	500	1000	-
5	-	-	200	1000	-	2000

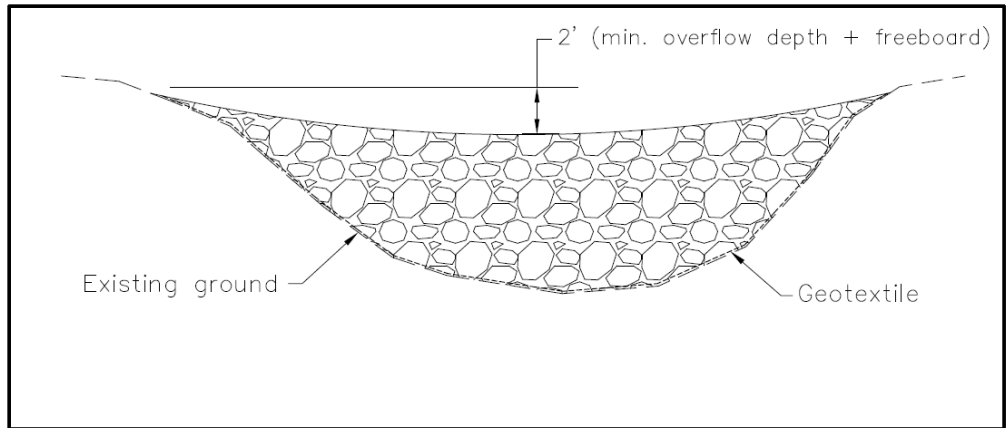

Figure RD-1 Typical Front View of Rock Filter Dam

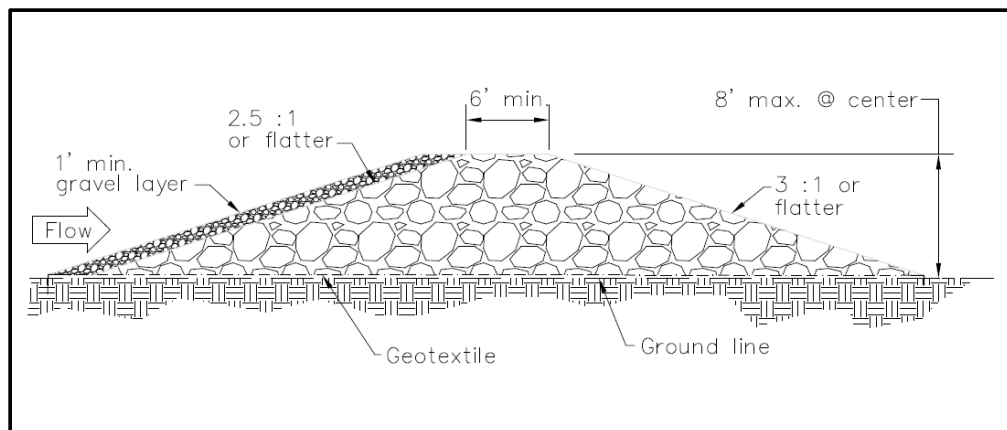

Figure RD-2 Typical Section of Rock Filter Dam

Sediment Barrier (SB)



Practice Description

A sediment barrier is a temporary sediment control practice installed downstream of a disturbed area intended to remove large-sized suspended sediment from sheet flow runoff by facilitating settling and to a lesser extent filtration. The most commonly used sediment barrier is a silt fence made up of a geotextile fabric that is anchored into the ground and attached to supporting posts and possibly reinforced with a wire fence or polypropylene netting. Other barrier materials could include sand bags, wattles, and various man-made materials and devices that can be used in a similar manner as a silt fence.

This practice applies downstream of small disturbed areas that yield runoff volumes less than the design storage volume. Barriers intercept runoff from upslope to form impoundments that temporarily detain runoff and allow sediment to settle out of the water and remain on the construction site.

Planning Considerations

Sediment barriers are used downslope of a disturbed area to intercept sediment-laden runoff. It is important that they be designed and installed to impound runoff from the design storm event and create favorable conditions for sediment to settle out of suspension. It is also important that the ends of sediment barriers are turned back upslope to prevent runoff from bypass around the ends of the barrier. Sediment barriers should be designed to safely overtop when the design storm is exceeded and provide for controlled dewatering of the detained runoff. Prevention

of scouring, erosion, and undermining at and under sediment barriers is also of utmost importance to ensure maximum impoundment capabilities.

The success of silt fences depends on a proper installation. Ideally, silt fences should be placed on the contour with each end turned up slope. When this installation is not feasible, “C” configurations (smiles), or “J” hooks should be used. Silt fences should be carefully installed to meet the intended purpose of intercepting and impounding sheet flow runoff. When properly installed, silt fences are effective at trapping coarse sediment but do not effectively reduce turbidity.

A silt fence is specifically designed to retain sediment transported by sheet flow from disturbed areas. Water flow through the silt fence often decreases over time as silts and debris “blind” or seal the geotextile fabric. Silt fences should be installed to be stable under the flows expected from the site. Generally, silt fences should not be installed across streams, ditches, waterways, or other concentrated flow areas. When properly designed and installed, silt fences can be used as a Check Dam (See Check Dam).

Silt fences are composed of geotextile (i.e., woven and non-woven) supported between steel or wooden posts. Silt fences are commercially available with geotextile attached to the post and can be rolled out and installed by driving the post into the ground. This type of silt fence is simple to install, but more expensive than some other installations. Silt fences must be trenched in at the bottom to prevent runoff from undermining the fence and developing rills under the fence. Locations with high runoff flows or velocities (steeper slopes and higher Runoff Curve Numbers) should use either a wire or polypropylene net reinforcement. In addition, decreasing the spacing between support posts will improve the structural integrity of the silt fence in these areas.

The “off-set” trench installation method (See Fig. SB-1) is now the preferred method of silt fence installation. This involves a conventional 6 in. x 6 in. trench or 6 in. slice installation to bury the geotextile, with the posts and wire installed 6 in. downslope of the trench or slice. The wire (when used) is on top of the ground surface and not in a trench. This installation has proven to have less potential for undermining than any installation tested at the Auburn University Stormwater Research Facility.

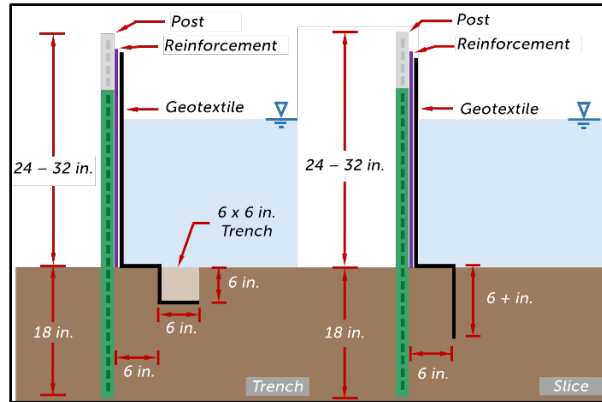

Figure SB-1 Off-Set Installation

Design Criteria (for silt fence)

Silt fence installations are normally limited to situations in which only sheet or overland flow is expected because the practice cannot pass the volumes of water generated by channelized flows. Silt fences are normally constructed of synthetic fabric (geotextile) and the life is expected to be the duration of most construction projects. Silt fence geotextile should conform to the property requirements found in AASHTO M288 shown in Table SB-1 as follows:

Table SB-1 Silt Fence Geotextile Fabric Requirements per AASHTO M288

Requirement	Test Methods	Units	Type A supported fence	Type B unsupported fence
Grab Strength	ASTM D4632/D4632M	N	Machine Direction	400
			X-Machine Direction	400
Permittivity	ASTM D4491	sec ⁻¹	0.05	0.05
Apparent Opening Size	ASTM D4751	mm	0.60 max avg roll value	0.60 max avg roll value
Ultraviolet stability (retained strength)	ASTM D4355/4355M	%	70% after 500 h of exposure	70% after 500 h of exposure

Note: ALDOT has an approved products list for geotextile

As a general rule-of-thumb the drainage area behind the silt fence should not exceed ¼ acre per 100 linear feet of silt fence for non-reinforced fence and ½ acre per 100 feet of reinforced silt fence. However, silt fence segments must be designed to impound runoff from the design storm event. Selection of the design storm should be based on site-specific characteristics including project location, duration of disturbance, and acceptable levels of risk to downstream receiving waters. Lacking site-specific guidance, a 2-yr, 24-hr design storm event is recommended.

Overflow Outlet and Dewatering

A silt fence segment must be designed for dewatering and overflow. Since geotextile materials blind or clog over time an effective means for dewatering must be included to prepare the silt fence for subsequent storms and minimize the chance of overtopping or periods of excessive ponding. The silt fence, at full storage capacity, should dewater in 4 to 12 hours. Overflow outlet(s) must be included for runoff that exceeds the design storm event and must convey the peak flow rate for the design storm event. One outlet option which has been well tested is a perforated board with a weir. This is installed in a break along the silt fence, which is sealed to the board. The break should be located at the lowest point of the silt fence segment. The board has several 1 in. diameter orifices, and a v-notch weir at the top, placed 18 in. from the bottom, to maintain volumetric storage (Fig. SB-2).

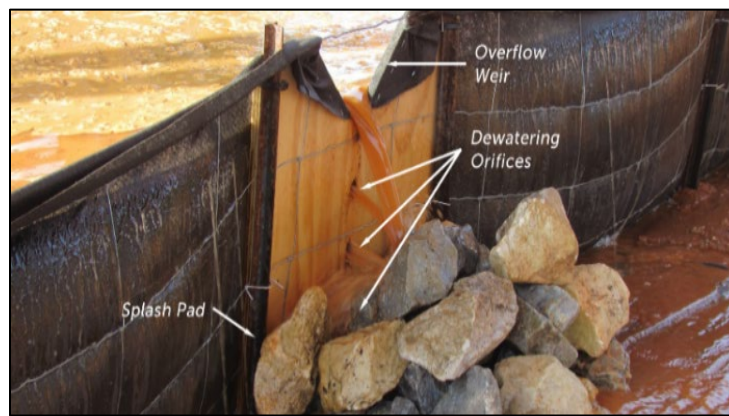

Figure SB-2 Example dewatering board & overflow weir.

Discharge from silt fence segments should be controlled to be non-erosive. Erosion control or scour protection, such as a geotextile splash apron and/or riprap, must be used immediately downstream of the dewatering and overflow outlet.

Type A Silt Fence

Type A fence shall be a minimum of 24 in. and not more than 32 in. above ground with wire reinforcements and is used on sites needing the highest degree of protection by a silt fence. The wire reinforcement is necessary because this type of silt fence is used for the highest runoff and flow situations. Wire fence should be made of 14-gauge wire with 6 in. x 6 in. openings (Note: ALDOT wire spacing may differ). Equivalent backing or reinforcement is allowed for wire reinforcement if it is sewn in or physically attached to the silt fence fabric. Type A silt fence should be used where runoff flows or velocities are particularly high or where slopes exceed a vertical height of 10 feet. Staked tie backs on each end of a Type A silt fence may be necessary to prevent overturning. Tie backs should also be used at points of possible concentration and overtopping if site conditions do not allow for the silt fence to be installed on the contour.

Provide an overflow outlet with a riprap splash pad with a geotextile underlay or other outlet protection device for any point where flow may overtop the silt fence.

The silt fence should be installed as shown in Figure SB-3. Maximum post spacing is 10 ft. In situations where runoff flows parallel with the silt fence when in perimeter control applications, 10 ft spacing is adequate. J-hooks should also be considered for long parallel flow scenarios to slow flow velocity and create areas of impoundments, thereby reducing scour potential under the silt fence. For the portion of the silt fence that creates the J-hook impoundment area, the maximum post spacing should be reduced to 5 ft. to support the hydrostatic loads. For all installations that intercept flow perpendicularly to the slope causing a concentrated impoundment, the maximum post spacing should be reduced to 5 ft. Materials for posts, post size, and fasteners are shown in Tables SB-2 and SB-3. Do not use “light weight” steel posts commonly found at building supply stores. Details for overlap of Type A silt fence is available from The Alabama Department of Transportation construction drawings and shown in Figure SB-4.

Geotextile silt fence material should be looped over each post and the top of the wire to prevent sagging. A “hog ring” attachment should be made each 1 ft along the top of the wire.

Table SB-2 Post Size for Silt Fence

Silt Fence	Minimum Length	Type of Post	Size of Post
Type A	4 ft	Steel “T” Post	1.25 lb./ft min.
Type B	4 ft	Soft Wood Oak Steel	3 in. diameter or 2X4 1.5 in. X 1.5 in. 1.33 lb./ft min.

Table SB-3 Wood Post Fasteners for Silt Fence

Fastener	Gauge	Crown	Legs	Staples/Post
Wire Staples	17 min.	¾” wide	½” long	5 min.
	Gauge	Length	Button Heads	Nail/Post
Nails	14 min.	1”	¾” long	4 min.

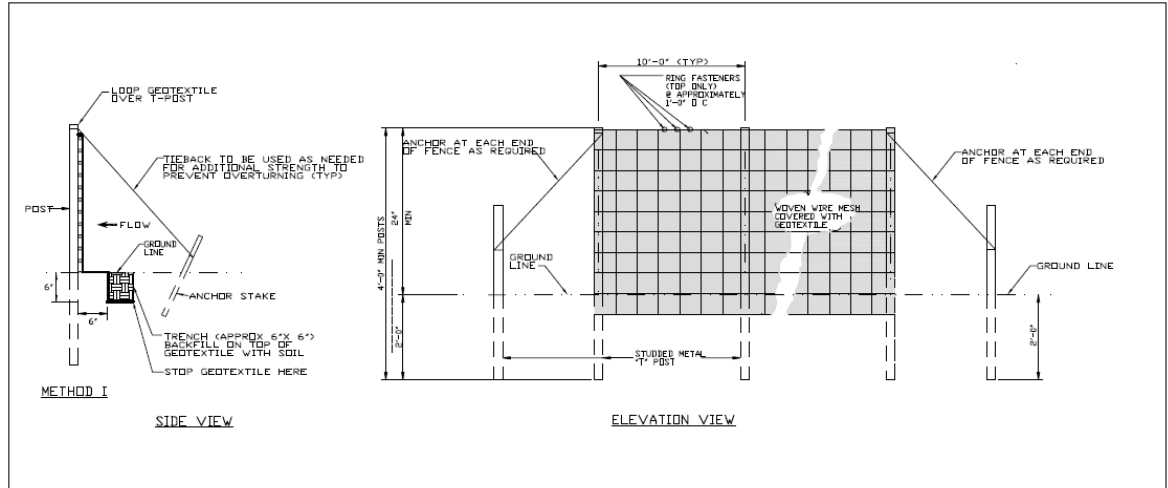

Figure SB-3 Silt Fence-Type A
(For post material requirements see Tables SB-2 and SB-3)

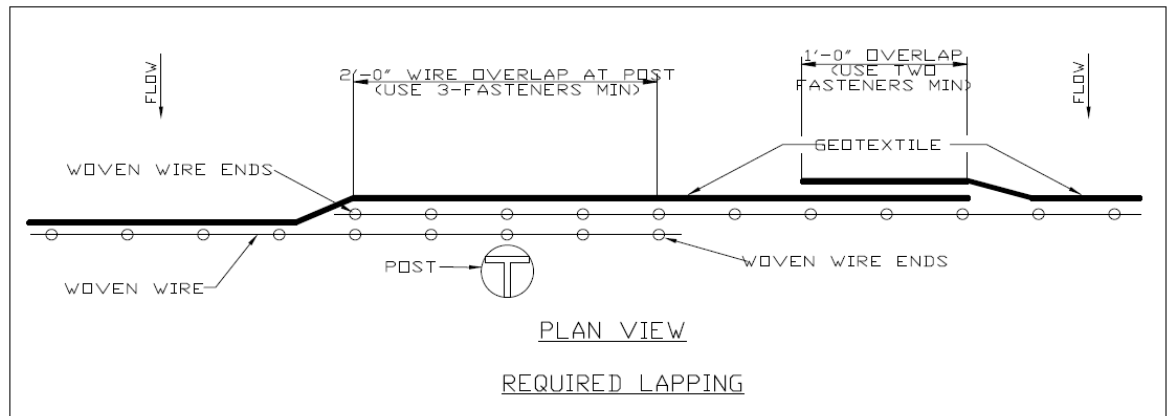

Figure SB-4 Type A Silt Fence Overlap

Type B Silt Fence

This 36 in. wide geotextile fabric should be used on developments where the life of the project is short (6 months or less) and there is less need for protection from a silt fence.

The silt fence should be installed as shown in Figure SB-5. Post spacing is either 4 ft or 6 ft based on geotextile elongation % (see note on Figure SB-5). Materials for posts and fasteners are shown in Tables SB-2 and SB-3. Details for overlap of the silt fence and fastener placement are shown in Figure SB-6. Provide overflow and dewatering devices if needed.

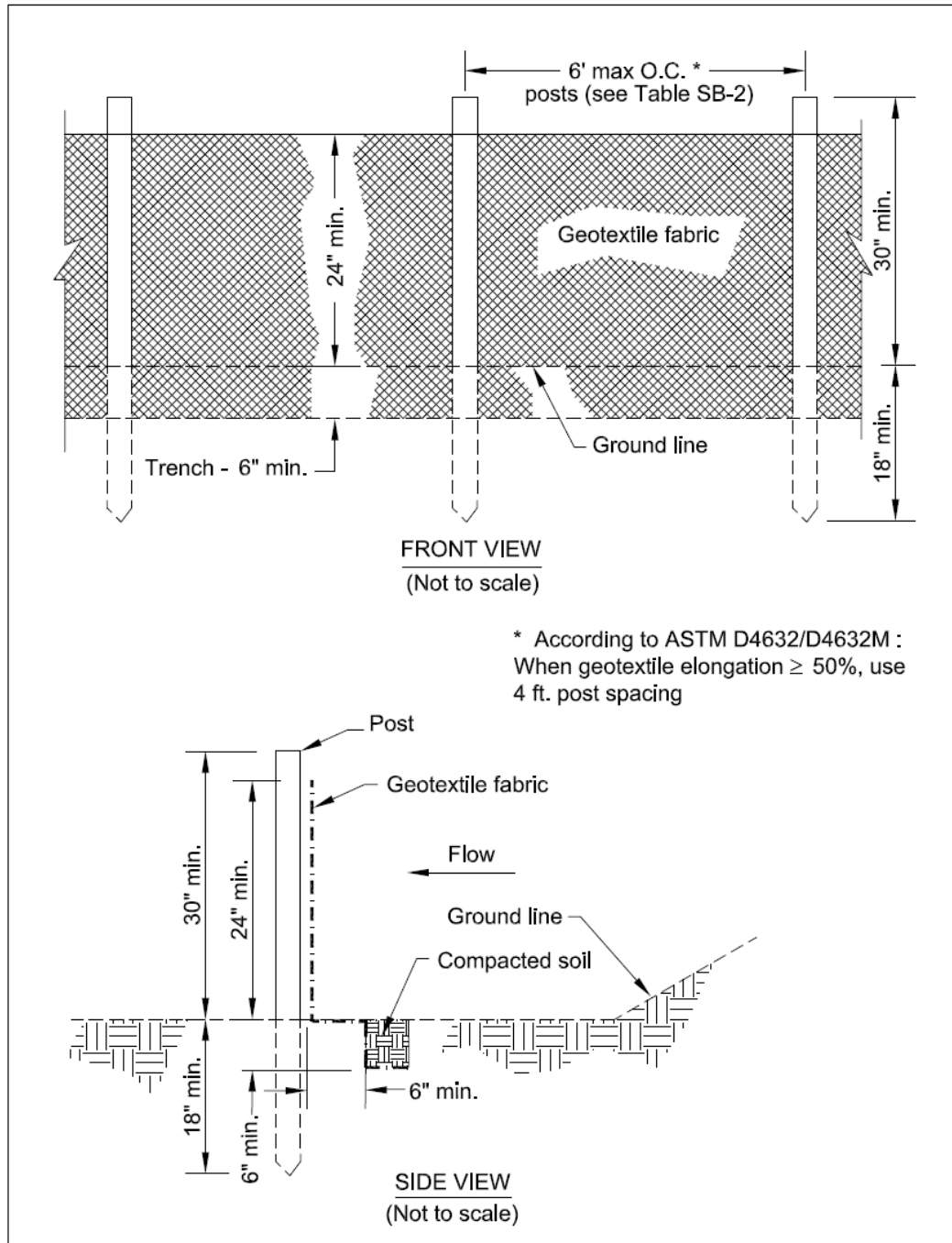

Figure SB-5 Silt Fence - Type B
(For post material requirements see Tables SB-2 and SB-3)

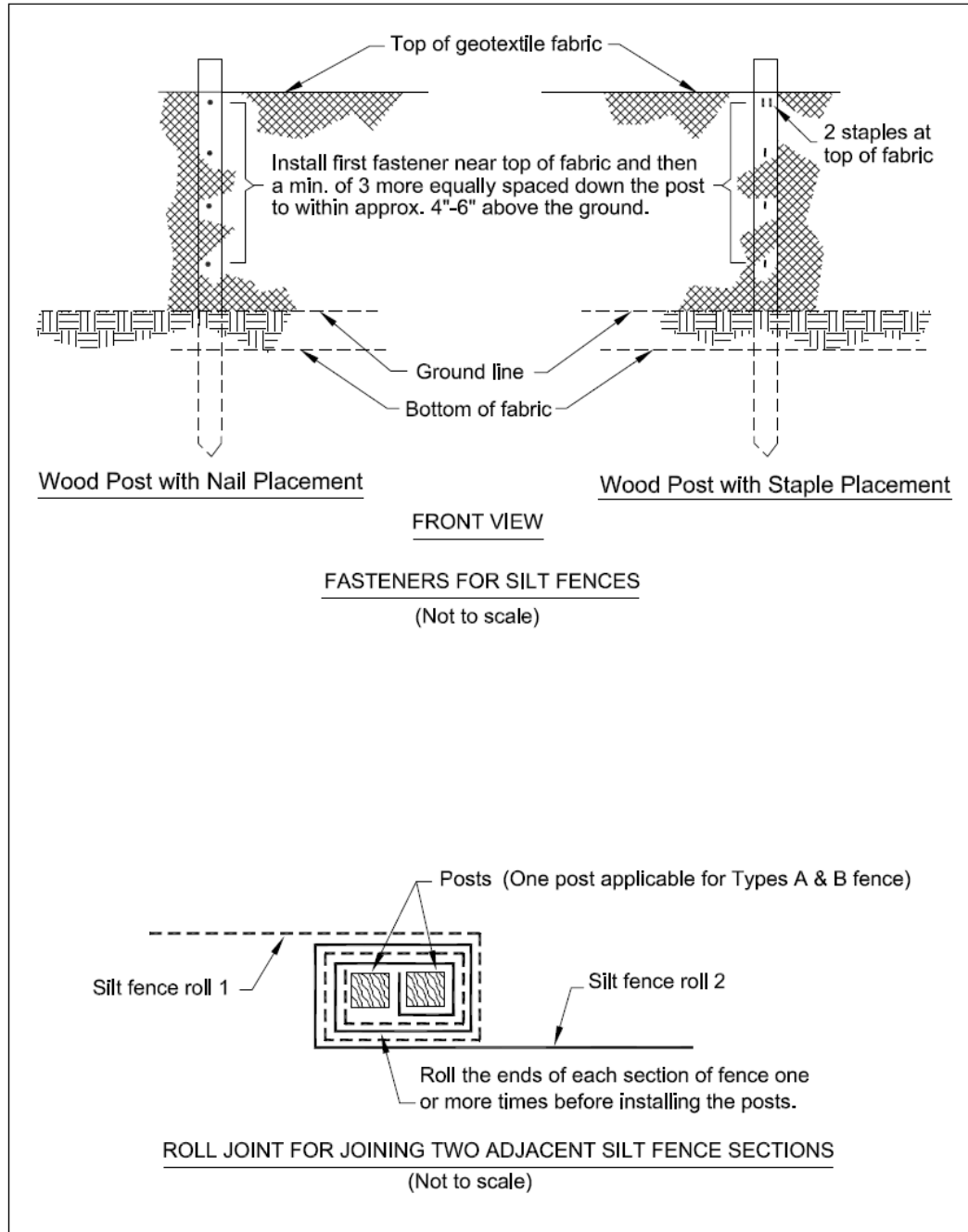

Figure SB-6 Silt Fence Installation Details for Type B

Sediment Basin (SBN)



Practice Description

A temporary impoundment designed and constructed to capture stormwater runoff and soil particles. This practice applies to sites where more storage is needed than provided by other sediment control practices and where turbidity must be reduced.

Planning Considerations

Sediment basins are needed where drainage areas are too large for other sediment control practices.

Select locations for basins during initial site evaluation. Locate basin so that sudden failure should not cause loss of life or serious property damage. Install sediment basins before any site grading takes place within the drainage area.

Select sediment basin sites to capture sediment from all areas that are not treated adequately by other sediment control measures. Always consider access for cleanout and disposal of the trapped sediment. Locations where a pond can be formed by constructing a low dam across a natural swale are generally preferred to sites that require excavation. Where practical, divert sediment-free runoff away from the basin. Ensure the slopes of the basin are stabilized to prevent erosion by vegetating or using a non-woven geotextile.

Because the auxiliary spillway is used relatively frequently, it is generally stabilized using geotextile and riprap that can withstand the expected flows and velocities without causing erosion. The spillway should be placed as far from the inlet of the basin as possible to maximize sedimentation before discharge. The spillway should be in natural ground (not over the embankment) to the greatest extent possible.

The use of approved flocculants properly introduced into the turbid runoff water should be considered to help polish the discharge from the basin for meeting turbidity requirements. Flocculant is best introduced upstream of the basin in a turbulent flow area.

A forebay or sump area prior to the basin should be considered for capture of heavier soil particles. Forebays also provide a more localized area for removing captured sediment and can extend maintenance cycles for the basin.

Sediment Basin technology can be retrofitted on Stormwater Detention Basins during the construction phase of a project.

Design Criteria

Inlet Structure

Turbid runoff should be directed to an inlet structure that conveys the runoff into the basin without causing erosion of the basin itself. The inlet structure must be positioned so that flows enter the basin from the opposite side of the discharge outlet.

Baffles

Porous baffles should be installed perpendicular between the inlet and outlet of the basin to effectively spread the flow across the entire width of a sediment basin and cause increased deposition within the basin. Water flows through the baffle material, but is slowed sufficiently to impound flow, causing it to spread across the entire width of the baffle (Figure SBN-1). Spreading the flow in this manner uses the full cross section of the basin and reduces turbulence, which shortens the time required for sediment to be deposited.

The installation should be similar to a sediment barrier (silt fence) (Figure SBN-2) using posts and wire backing. The most effective material for a baffle is two layers of 700 - 900 g/m² coir erosion blanket (Figure SBN-3). Other materials proven by research to be equivalent in this application may be used. A support wire or rope across the top will help prevent excessive sagging if the material is attached to it with appropriate ties. Another option is to use a sawhorse type of support with the legs stabilized with rebar inserted into the basin floor. These structures work well and can be prefabricated off site and quickly installed.

Baffles need to be installed correctly to fully provide their benefits. Refer to Figure SBN-2 and the following key points:

- The baffle material needs to be secured at the bottom and sides by using staples or stakes, trenching, or securing horizontally to the bottom. Flow should not be allowed under, over, or around the baffle. The height of the baffle should be the full depth of the basin, including the depth of flow through the auxiliary spillway.
- Most of the sediment will accumulate in the first bay, so this should be readily accessible for maintenance.

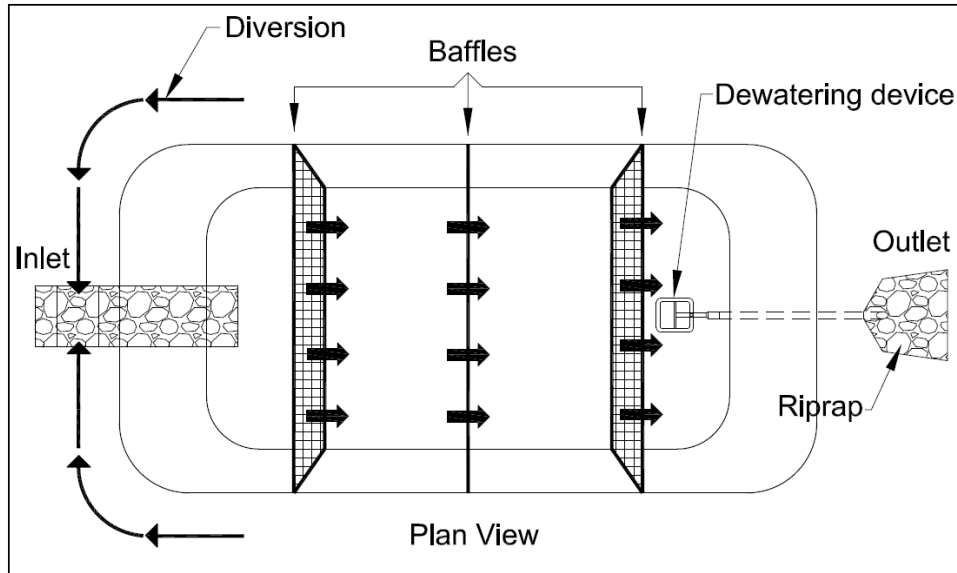

Figure SBN-1 Porous Baffles in a Sediment Basin

(modified from the North Carolina Erosion and Sediment Control Planning and Design Manual.)

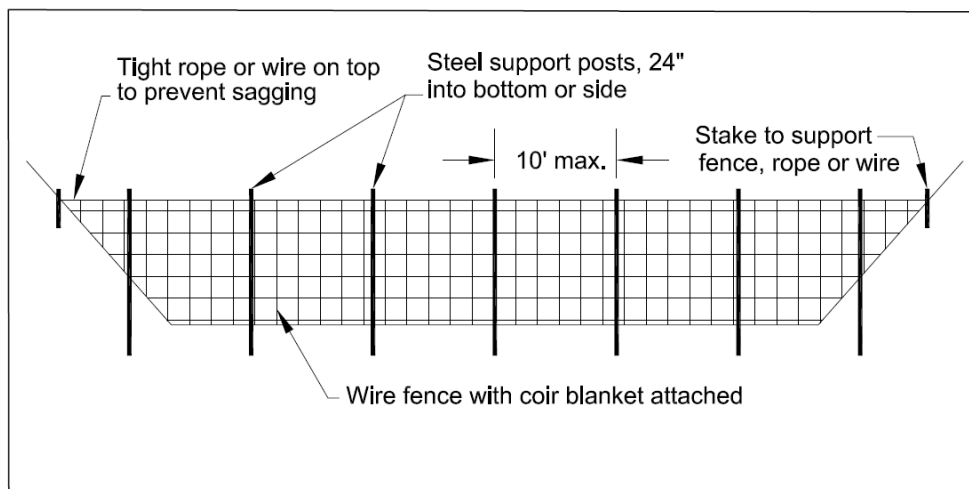

Figure SBN-2: Cross-Section of a Porous Baffle in a Sediment Basin.

Note: there is no weir because the water flows through the baffle material.
(from North Carolina Erosion and Sediment Control Planning and Design Manual.)



Figure SBN-3: Example of Porous Baffle Made of Coir Erosion Blanket as Viewed from the Inlet

Basin Dewatering

Sediment basins should be dewatered from the surface. A device often used for this is a skimmer that withdraws water from the basin's water surface, thus removing the highest quality water for delivery to the uncontrolled environment. One type of skimmer is shown in Figure SBN-4. By properly sizing the skimmer's control orifice, the skimmer can be made to dewater a design hydrologic event in a prescribed period.

An advantage of the skimmer is that it can be reused on future projects. Skimmers are generally maintenance free, but may require occasional maintenance to remove debris from the orifice.

All basin dewatering devices must dewater the basin from the top of the water surface. The rate of dewatering must be controlled. A dewatering time of 48 to 120 hours (2 to 5 days) is required for the basin to function properly.

If turbidity requirements are unattainable, the designer may want to consider adding a valve to the outlet of the discharge pipe to contain turbid runoff. This provides additional settling time and may allow the captured water to be actively treated with flocculant prior to discharge, if deemed necessary. However, if the treated water is not timely discharged, the basin storage volume will not be available for subsequent rainfall events occurring on site that result in additional runoff.

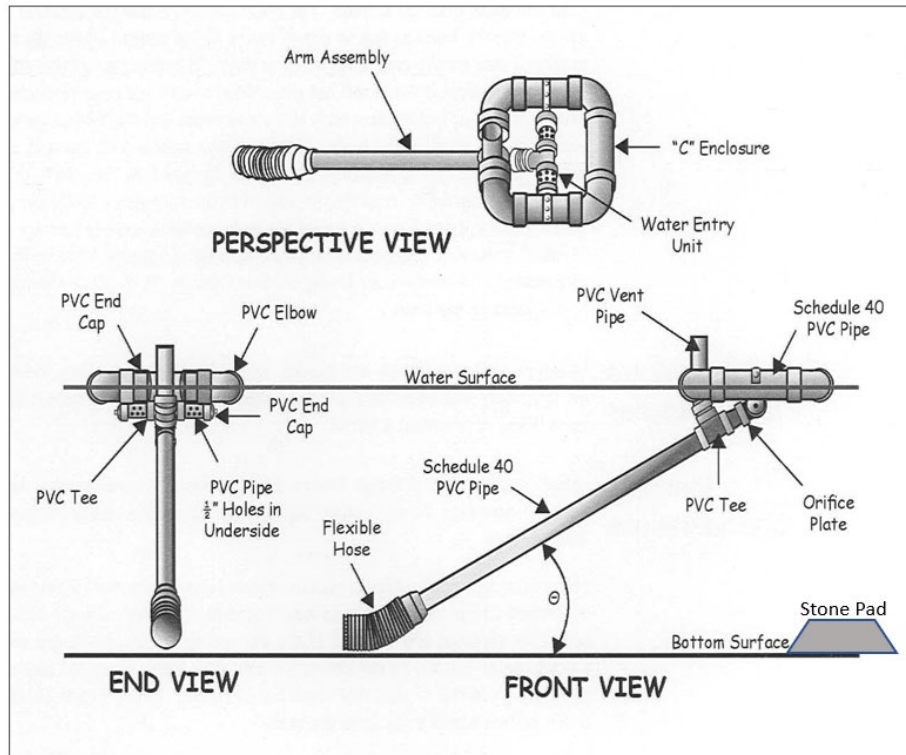

Figure SBN-4: Schematic of a Skimmer
 (modified from Pennsylvania Erosion and Sediment Pollution Control Manual, March 2000)

Design Criteria

Summary:	Temporary Sediment Trap
Auxiliary Spillway:	Trapezoidal open channel spillway with non-erosive lining. 10 – year, 24 – hour rainfall event
Recommended Maximum Drainage Area:	10 acres
Minimum Standing Pool Depth:	1 foot
Minimum Volume:	3,600 cubic feet per acre of drainage area
Minimum L/W Ratio:	2:1
Minimum Depth:	2 feet
Dewatering Mechanism:	Skimmer(s) or other approved basin dewatering device.
Dewatering Time:	2 – 5 days
Baffles Required:	3

Compliance with Laws and Regulations

Design and construction should comply with state and local laws, ordinances, rules, and regulations.

Design Basin Life

Structures intended for more than 3 years of use should be designed as permanent structures. Procedures outlined in this section do not apply to permanent structures.

Dam Height

To ensure public safety, the maximum dam height should be 10 feet, measured from the designed (settled) top elevation of the dam to the lowest point at the downstream toe.

Drainage Area

To minimize risk to the public and environment, the maximum drainage area for each sediment basin should be minimized. Diverting water from undisturbed areas can reduce the size of the basin. The recommended maximum drainage area is 10 acres.

Basin Locations

Select areas that:

- Are not intermittent or perennial streams
- Allow a maximum amount of construction runoff to be brought into the structure
- Provide capacity for storage of sediment from as much of the planned disturbed area as practical
- Exclude runoff from undisturbed areas where practical
- Provide access for sediment removal throughout the life of the project
- Interfere minimally with construction activities

Basin Shape

Ensure that the flow length to basin width ratio is 2:1 or larger to improve trapping efficiency. Length is measured at the elevation associated with the minimum storage volume. Generally, the bottom of the basin should be level to ensure the baffles function properly. The area between the inlet and first baffle can be designed with reverse grade to improve the trapping efficiency.

Research has shown that the surface area of the basin should be maximized to improve trapping efficiency. Results of tests show that a surface area of 325 sq. ft. per cubic feet per second of discharge associated with the peak discharge for the 10-year, 24-hour event, is needed for effective trapping efficiency. Designers should check to see if this surface area is possible on the site.

Storage Volume

Ensure that the sediment storage volume of the basin is at least 3,600 cubic feet per acre for the area draining into the basin. Volume is measured below the crest of the auxiliary spillway crest and above the standing pool elevation. Remove sediment from the basin when approximately one-half of the sediment storage volume has been filled.

Runoff in excess of 1 inch per acre from the drainage basin will not be contained in the 3,600 cubic feet per acre requirement. More storage volume may be needed for local conditions or requirements. Adding dead storage may be necessary on some sites in order to retain a portion of the runoff within the basin.

Baffles

Space the baffles to create equal zones of volume within the basin.

The top of the baffle should be the same elevation as the maximum water depth flowing through the auxiliary spillway. Baffles are most effective at a height of 3 feet; however, site conditions may warrant taller baffles.

Baffles should be designed to go up the sides of the basin banks, so water does not flow around the baffles. Most of the sediment will be captured in the first bay. Smaller particle size sediments are captured in the latter bays.

The design life of the baffle fabric can be up to 3 years but may need to be replaced more often if damaged or clogged.

Spillway Capacity

The auxiliary spillway system must carry the peak runoff from the 10-year 24-hour storm with a minimum 1 foot of freeboard (distance between the surface of the water with the spillway flowing full and the top of the embankment). Base runoff computations on the most severe soil cover conditions expected in the drainage area during the effective life of the structure.

Sediment Cleanout Elevation

Determine the elevation at which the invert of the basin would be half-full. This elevation should also be marked in the field with a permanent stake set at this ground elevation (not the top of the stake).

Basin Dewatering

The basin should be provided with a surface outlet. A floating skimmer should be attached to a Schedule 40 PVC barrel pipe of the same diameter as the skimmer arm. The skimmer apparatus will control the rate of dewatering. The skimmer should be sized to dewater the basin in 48-120 hours (2-5 days). The barrel pipe should be located under the embankment. When potential soil piping is a concern during the life of the project, place at least one anti-seep collar at the center of the embankment projecting a minimum of 1.5 ft. in all directions from the pipe. A filter diaphragm can be used in lieu of an anti-seep collar (See NRCS National Engineering Handbook Chapter 45 – Filter Diaphragms for design procedures). The barrel pipe outlet must be stable and not cause erosion.

*Skimmer Orifice Diameter***Skimmer Selection Procedure**

The manufacturer's skimmer performance charts are recommended for use in selecting skimmers for use in dewatering sediment control basins. Always verify performance with the manufacturer's information.

Required input data:

Basin volume = _____ ft³

Desired dewatering time = _____ days

Procedure:

1. First use the basin volume (ft³) and the desired dewatering time (days) and determine the required skimmer outflow rate in cubic feet per day (ft³/d) from the following equation

$$Q = \frac{V}{t_d}$$

2. Scan the manufacturer's skimmer performance charts and select the (a) skimmer size and (b) the skimmer orifice diameter (in inches) if desired.

Example: Select a skimmer that will dewater a 20,000 ft³ sediment basin in 3 days.

Solution: First compute the required outflow rate as

$$Q = \frac{V}{t_d} = \frac{20000 \text{ ft}^3}{3d} = 6670 \text{ ft}^3 / d$$

Now go to the manufacturer's selection charts and select an appropriate skimmer. For example, a 2-inch skimmer with no orifice could have an outflow rate of 5,429 ft³/d, which will require about 3.5 days to dewater the basin. A 4-inch

skimmer with a 2.5-inch diameter orifice could have an outflow rate of 8,181 ft³/d and dewater the basin in about 2.5 days.

Example: A More Precise Alternative: Most skimmers come with a plastic plug that can be drilled forming a hole that will limit the skimmer's outflow to any desired rate. Thus, for a specific skimmer the orifice that will dewater a basin in a more precisely chosen time can be determined. The flow through an orifice can be computed as

$$Q = CA\sqrt{2gH}$$

where C is the orifice coefficient (usually taken to be 0.6), A is the orifice cross-sectional area in ft², g is the acceleration of gravity (32.2 ft./sec²), and H is the driving head on the orifice center in feet. The orifice equation can be simplified to yield the orifice flow in gpm using the diameter D (in inches) and the head in feet as

$$Q = 12D^2\sqrt{H} .$$

Or the orifice flow in ft³/d using the diameter D (in inches) and the head in feet as

$$Q = 2310D^2\sqrt{H} .$$

If we solve the orifice equation for the orifice diameter using the desired outflow rate (6670 ft³/d) and the head driving water through the skimmer (0.333 ft. for a 4-inch skimmer) as

$$D = \sqrt{\frac{Q}{2310\sqrt{H}}} = \sqrt{\frac{6670}{2310\sqrt{0.333}}} = 2.24inches$$

We see that if the plastic plug were drilled to a diameter of 2.24 inches and placed in a 4-inch skimmer, the dewater rate would be 6,670 ft³/d and the 20,000 ft³ basin would dewater in 3 days.

Outlet Protection

Provide outlet protection to ensure erosion does not occur at the pipe outlet.

Basin Auxiliary Spillway

The auxiliary spillway should carry the peak runoff from a 10-year storm. The spillway should have a minimum 10-foot bottom width, 0.5-foot flow depth, and 1-foot freeboard above the design water surface.

Construct the entire flow area of the spillway in undisturbed soil to the greatest extent possible. Cross section should be trapezoidal, with side slopes 3:1 or flatter for grass spillways (Figure SBN-5) and 2:1 for riprap. Select a vegetated lining to meet flow requirements and site conditions.

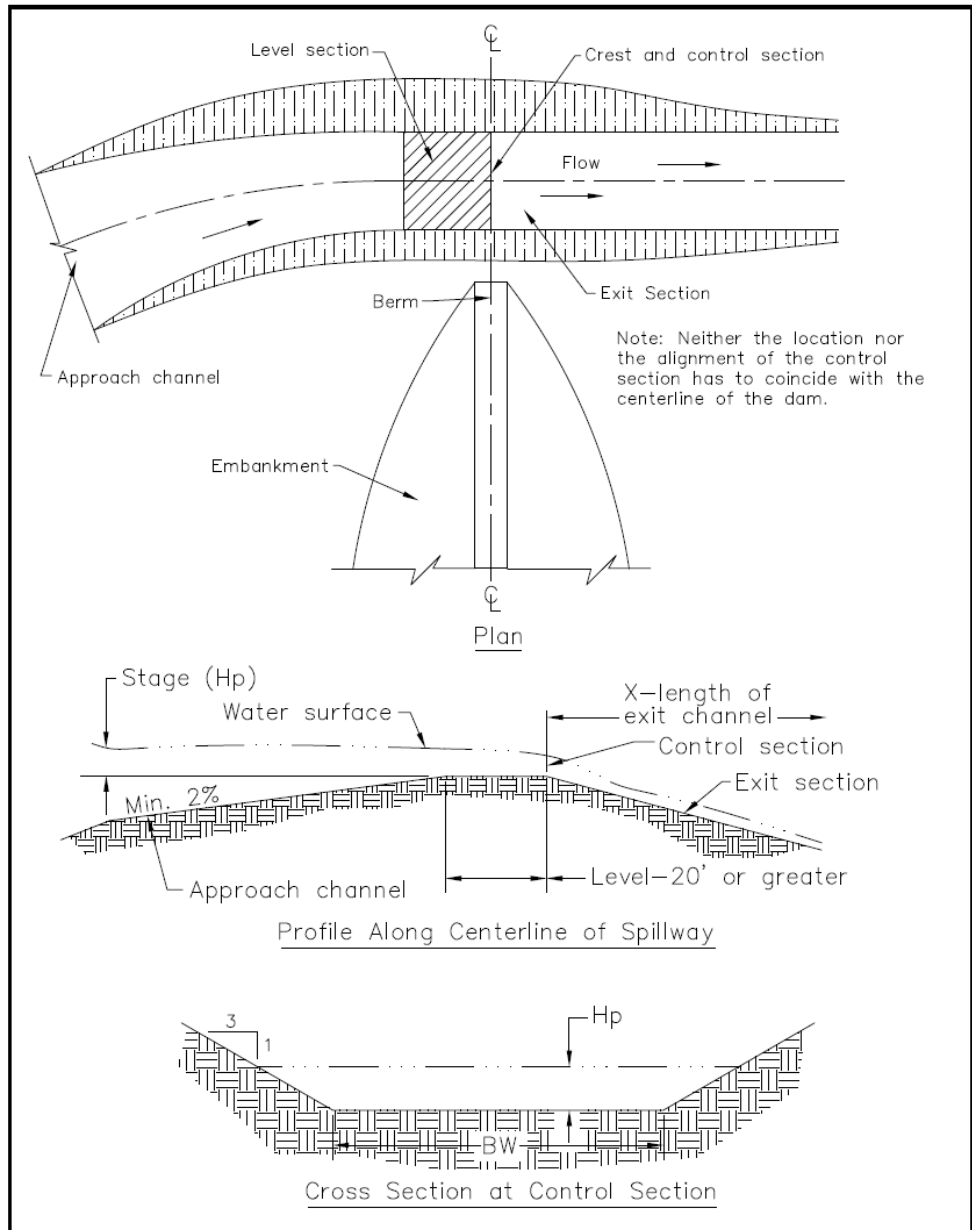

Figure SBN-5: Excavated Grass Spillway Views

Inlet Section

Ensure that the approach section has a slope toward the impoundment area of not less than 2% and is flared at its entrance, gradually reducing to the design width of the control section. The inlet portion of the spillway may be curved to improve alignment.

The Control Section

The control section of the spillway should be level and straight and at least 20 ft. long for grass spillways and 10 feet for riprap. Determine the width and depth for the required capacity and site conditions. Wide, shallow spillways are preferred because they reduce outlet velocities.

The Outlet Section

The outlet section of the spillway should be straight, aligned and sloped to assure supercritical flow with exit velocities not exceeding values acceptable for site conditions.

Outlet Velocity

Ensure that the velocity of flow from the basin is nonerosive for existing site conditions. It may be necessary to stabilize the downstream areas or the receiving channels.

Embankment

Embankments should not exceed 10 feet in height, measured at the center line from the original ground surface to the designed (settled) top elevation of the embankment. Keep a minimum of 1 foot between the designed (settled) top of the dam and the design water level in the auxiliary spillway. Additional freeboard may be added to the embankment height which allows flow through a designated bypass location. Embankments are generally constructed with a minimum top width of 8 feet and side slopes of 2.5:1 or flatter.

When needed to control seepage, a cutoff trench should be installed under the dam at the centerline. The trench would be at least 2 feet deep with 1.5:1 side slopes, and sufficiently wide (at least 8 ft.) to allow compaction by machine.

Embankment material should be a stable mineral soil, free of roots, woody vegetation, rocks or other objectionable materials, with adequate moisture for compaction. Place fill in 9-inch layers through the length of dam and compact by routing construction hauling equipment over it. Maintain moisture and compaction requirements according to the plans and specifications. Hauling or compaction equipment must traverse each layer so that the entire surface has been compacted by at least one pass of the equipment wheels or tracks.

Excavation

Where sediment pools are formed or enlarged by excavation, keep side slopes at 2:1 or flatter for safety.

Erosion Protection

Minimize the area disturbed during construction. Divert surface water from disturbed areas. When possible, delay clearing the sediment impoundment area until the dam is in place. Keep the remaining temporary pool area undisturbed. Stabilize the spillway, embankment, and all disturbed areas with permanent vegetation. The basin bottom should also be established to a vegetative cover or covered with non-woven geotextile to prevent erosion of the basin itself and promote sediment deposition.

Trap Efficiency

Improve sediment basin trapping efficiency by employing the following considerations in the basin design:

- Surface area—In the design of the settling pond, allow the largest surface area possible. The shallower the pool, the better.
- Length—Maximize the length-to-width ratio of the basin to provide the longest flow path possible.
- Baffles—Provide a minimum of three porous baffles to evenly distribute flow across the basin and reduce turbulence.
- Inlets—Area between the sediment inlets and the basin bottom should be stabilized by geotextile material, riprap with geotextile, a pipe drop, or other similar methods (Figure SBN-6 shows the area with rocks). Inlets to basin should be located the greatest distance possible from the spillway.
- Dewatering—Allow the maximum reasonable detention period before the basin is completely dewatered (minimum of at least 48 hours).
- Inflow rate—Reduce the inflow velocity to nonerosive rates and divert all sediment-free runoff
- Establish permanent vegetation in the bottom and side slopes of the basin.
- Introduce the appropriate flocculent material at the turbulent entrance of the runoff water into the basin. Apply the flocculent according to manufacturer's recommendations.

Safety

Avoid steep side slopes. Fence basins properly and mark them with warning signs if trespassing is likely. Follow all State and local safety requirements.

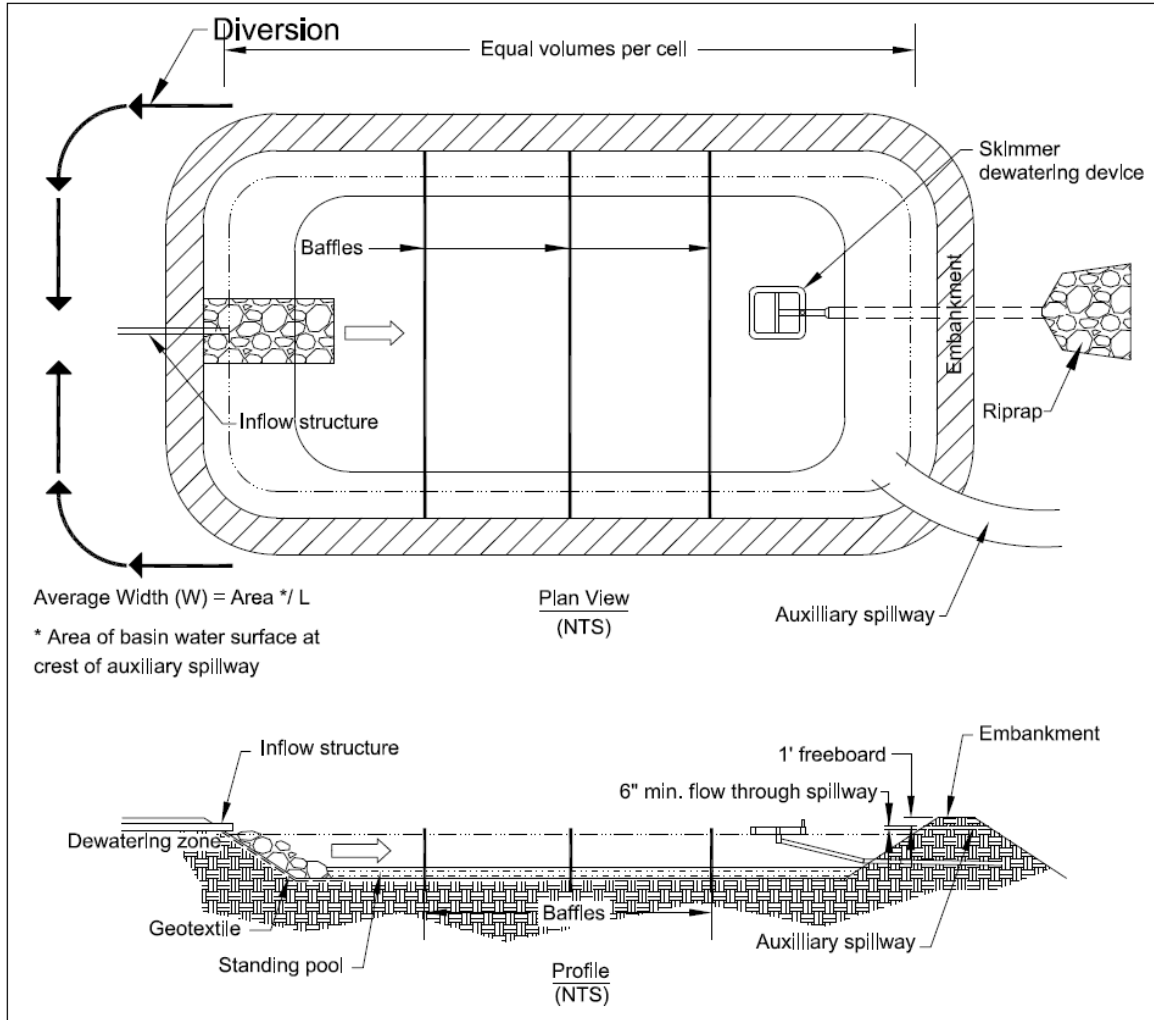

Figure SBN-6: Example of a Sediment Basin with a Skimmer Outlet and Auxiliary Spillway
 (modified from Pennsylvania Erosion and Sediment Control Manual, March 2000)

Design Procedure

Step 1. Determine peak flow, Q_{10} , for the basin drainage area using the NRCS runoff curve number method.

Step 2. Determine any site limitations for the sediment pool elevation, auxiliary spillway or top of the dam.

Step 3. Determine basin volumes:

- Determine standing pool elevation.
- Compute minimum volume required (3,600 ft³/acre of drainage area) above the standing pool.
- Specify sediment cleanout level to be clearly marked (one-half the design volume). Specify that the basin area is to be cleared after the dam is built.

Step 4. Determine area of basin, shape of basin, and baffles:

- Check length/width ratio (should be 2:1 or larger) and the surface area (325 sq.ft./ Q_{p10}).
- Ensure the bottom of the basin is level.
- Design and locate a minimum of 3 coir baffles. The baffle spacing should produce equal volumes of storage within the basin when the basin is full. The top elevation of the baffles will be set in Step 7.

Step 5. Size the skimmer, skimmer orifice, and barrel pipe.

Use Table SBN-1 or the precise alternative design to size the orifice. Generally, a Schedule 40 PVC barrel pipe the same size as the skimmer arm is used under the embankment.

Step 6. Design the anti-seep collar (optional based on site conditions).

Ensure that antiseep collar is no closer than 2 ft from a pipe joint and as close to the center of the embankment as possible. Collar must project at least 1.5 ft. from the pipe and be watertight.

Step 7. Determine the auxiliary spillway dimensions.

Size the spillway bottom width and flow depth to handle the Q_{10} peak flow. Tables SBN-1 and SBN-2 can be used for the design process for grassed auxiliary spillways. Use appropriate design procedures for spillways with other surfaces. Set top of baffles at the elevation of the designed maximum flow depth of the auxiliary spillway.

Step 8. Spillway approach section.

Adjust the spillway alignment so that the control section and outlet section are straight. The entrance width should be 1.5 times the width of the control section

with a smooth transition to the width of the control section. Approach channel should slope toward the reservoir no less than 2%.

Step 9. Spillway control section.

- Locate the control section in natural ground to the greatest extent possible.
- Keep a level area to extend at least 20 ft. (grass) or 10 ft. (riprap) upstream from the outlet end of the control section to ensure a straight alignment.
- Side slopes should be 3:1 (grass) or 2:1 (riprap).

Step 10. Design spillway exit section.

- Spillway exit should align with the control section and have the same bottom width and side slopes.
- Slope should be sufficient to maintain supercritical flow, but make sure it does not create erosive velocities for site conditions. (Stay within slope ranges in appropriate design tables.)
- Extend the exit channel to a point where the water may be released without damage.

Step 11. Size the embankment.

- Set the design elevation of the top of the dam a minimum of 1 ft. above the water surface for the design flow in the auxiliary spillway.
- Constructed height should be 10% greater than the design to allow for settlement.
- Set side slopes 2.5:1 or flatter.
- Determine depth of cutoff trench from site borings. It should extend to a stable, tight soil layer (a minimum of 2 ft. deep).
- Select borrow site remembering that the spillway cut may provide a significant amount of fill.

Step 12. Erosion control

- Select surface stabilization measures to control erosion.
- Select groundcover for auxiliary spillway to provide protection for design flow velocity and site conditions. Riprap stone over geotextile fabric may be required in erodible soils or when the spillway is not in undisturbed soils.
- Establish all disturbed areas including the basin bottom and side slopes to vegetation (see the Permanent Seeding practice).

Step 13. Safety.

- Construct a fence and install warning signs as needed.

Table SBN-1 Design Table for Vegetated Spillways Excavated in Erosion Resistant Soils (side slopes 3 horizontal: 1 vertical)

Discharge Q CFS	Slope Range		Bottom Width Feet	Stage Feet	Discharge Q CFS	Slope Range		Bottom Width Feet	Stage Feet
	Minimum Percent	Maximum Percent				Minimum Percent	Maximum Percent		
15	3.3	12.2	8	.83	80	2.8	5.2	24	1.24
	3.5	18.2	12	.69		2.8	5.9	28	1.14
20	3.1	8.9	8	.97	2.9	7.0	32	1.06	
	3.2	13.0	12	.81	2.5	2.6	12	1.84	
	3.3	17.3	16	.70	2.5	3.1	16	1.61	
25	2.9	7.1	8	1.09	2.6	3.8	20	1.45	
	3.2	9.9	12	.91	2.7	4.5	24	1.32	
	3.3	13.2	16	.79	2.8	5.3	28	1.22	
	3.3	17.2	20	.70	2.8	6.1	32	1.14	
30	2.9	6.0	8	1.20	2.5	2.8	16	1.71	
	3.0	8.2	12	1.01	2.6	3.3	20	1.54	
	3.0	10.7	16	.88	2.6	4.0	24	1.41	
	3.3	13.8	20	.78	2.7	4.8	28	1.30	
35	2.8	5.1	8	1.30	2.7	5.3	32	1.21	
	2.9	6.9	12	1.10	2.8	6.1	36	1.13	
	3.1	9.0	16	.94	2.5	2.8	20	1.71	
	3.1	11.3	20	.85	2.6	3.2	24	1.56	
	3.2	14.1	24	.77	2.7	3.8	28	1.44	
40	2.7	4.5	8	1.40	2.7	4.2	32	1.34	
	2.9	6.0	12	1.18	2.7	4.8	36	1.26	
	2.9	7.6	16	1.03	2.5	2.7	24	1.71	
	3.1	9.7	20	.91	2.5	3.2	28	1.58	
45	3.1	11.9	24	.83	2.6	3.6	32	1.47	
	2.6	4.1	8	1.49	2.6	4.0	36	1.38	
	2.8	5.3	12	1.25	2.7	4.5	40	1.30	
	2.9	6.7	16	1.09	2.5	2.7	28	1.70	
	3.0	8.4	20	.98	2.5	3.1	32	1.58	
50	3.0	10.4	24	.89	2.6	3.4	36	1.49	
	2.7	3.7	8	1.57	2.6	3.8	40	1.40	
	2.8	4.7	12	1.33	2.7	4.3	44	1.33	
	2.8	6.0	16	1.16	2.4	2.7	32	1.72	
60	2.9	7.3	20	1.03	2.4	3.0	36	1.60	
	3.1	9.0	24	.94	2.5	3.4	40	1.51	
	2.6	3.1	8	1.73	2.6	3.7	44	1.43	
	2.7	3.9	12	1.47	2.5	2.7	36	1.70	
	2.7	4.8	16	1.28	2.5	2.9	40	1.60	
70	2.9	5.9	20	1.15	2.5	3.3	44	1.52	
	2.9	7.3	24	1.05	2.6	3.6	48	1.45	
	3.0	8.6	28	.97	2.4	2.6	40	1.70	
	2.5	2.8	8	1.88	2.5	2.9	44	1.61	
	2.6	3.3	12	1.60	2.5	3.2	48	1.53	
80	2.6	4.1	16	1.40	2.5	2.6	44	1.70	
	2.7	5.0	20	1.26	2.5	2.9	48	1.62	
	2.8	6.1	24	1.15	2.6	3.2	52	1.54	
	2.9	7.0	28	1.05	2.4	2.6	48	1.70	
200	2.5	2.9	12	1.72	2.5	2.9	52	1.62	
	2.6	3.6	16	1.51	280	2.4	2.6	52	1.70
	2.7	4.3	20	1.35	300	2.5	2.6	56	1.69

Example of Table Use:

Given: Discharge, $Q_{10} = 87$ cfs, Spillway slope (exit section) = 4%.

Find: Bottom Width and Stage in Spillway.

Procedure: Using a discharge of 90 cfs, note that the spillway (exit section) slope falls within slope ranges corresponding to bottom widths of 24, 28, and 32 ft. Use bottom width of 32 ft, to minimize velocity. Stage in the spillway is 1.14 ft.

Note: Computations are based on: Roughness coefficient, $n = 0.40$ and a maximum velocity of 5.50 ft. per sec.

Table SBN-2 Design Table for Vegetated Spillways Excavated in Very Erodible Soils (side slopes 3 horizontal: 1 vertical)

Discharge Q CFS	Slope Range		Bottom Width Feet	Stage Feet
	Minimum Percent	Maximum Percent		
10	3.5	4.7	8	.68
15	3.4	4.4	12	.69
	3.4	5.9	16	.60
20	3.3	3.3	12	.80
	3.3	4.1	16	.70
	3.5	5.3	20	.62
25	3.3	3.3	16	.79
	3.3	4.0	20	.70
	3.5	4.9	24	.64
30	3.3	3.3	20	.78
	3.3	4.0	24	.71
	3.4	4.7	28	.65
	3.4	5.5	32	.61
35	3.2	3.2	24	.77
	3.3	3.9	28	.71
	3.5	4.6	32	.66
	3.5	5.2	36	.62
40	3.3	3.3	28	.76
	3.4	3.8	32	.71
	3.4	4.4	36	.67
	3.4	5.0	40	.64
45	3.3	3.3	32	.76
	3.4	3.8	36	.71
	3.4	4.3	40	.67
	3.4	4.8	44	.64
50	3.3	3.3	36	.75
	3.3	3.8	40	.71
	3.3	4.3	44	.68
60	3.2	3.2	44	.75
	3.2	3.7	48	.72
70	3.3	3.3	52	.75
80	3.1	3.1	56	.78

Example of Table Use:

Given: Discharge, $Q_{10} = 38$ cfs, Spillway slope (exit section) = 4%.

Find: Bottom Width and Stage in Spillway.

Procedure: Using a discharge of 40 cfs, note that the spillway (exit section) slope falls within slope ranges corresponding to bottom widths of 36 and 40 ft. Use bottom width of 40 ft., to minimize velocity. Stage in the spillway is 0.64 ft.

Note: Computations are based on: Roughness coefficient, $n = 0.40$ and a maximum velocity of 3.50 ft. per sec.

This Page Intentionally Left Blank

Bioretention Area (BA)



Source: Department of Environmental Resources, Prince George's County, MD

Practice Description

A bioretention area is a shallow, vegetated depression incorporated into a development's landscape to restore, as much as possible, an area's pre-development hydrology and provide both water quantity and water quality benefits.

Note: Only general guidance is provided for this practice. More specific information can be obtained from the Low Impact Development Handbook for the State of Alabama

<https://adem.alabama.gov/programs/water/waterforms/LIDHandbook.pdf>

Planning Considerations

Stormwater is conveyed as sheet flow to the bioretention area that temporarily stores runoff. As stormwater percolates through the bioretention area, soils and plants remove pollutants. Filtered stormwater is then directed to the conveyance system or if underlying soils are appropriate, stormwater is allowed to infiltrate to the aquifer below and provide recharge.

A bioretention area is a suitable stormwater practice for commercial, transportation, industrial, and residential developments. Applications include parking lot islands, roadway medians, roadside swales, and residential gardens positioned to collect roof and parking lot runoff. Bioretention is particularly effective on sites of 1 acre or less. Bioretention is used on larger sites with

multiple bioretention areas treating sub-drainages. In general, a bioretention area is a suitable stormwater management practice for residential subdivisions and high density/ultra-urban sites but not for regional-scale control. ^[2]

Examples of bioretention area applications are illustrated in Figure BA-1.

A bioretention area is designed with one of the two basic configurations: (1) with an underdrain connected to a stormwater collection system; or (2) without an underdrain (“no-underdrain”) and infiltration into a permeable soil profile, providing groundwater recharge. The underlying soil is the main factor determining which configuration is used. ^[2] The no-underdrain design is a better choice when feasible because of aquifer recharge. However, the underdrain design is likely to be more appropriate over much of Alabama because of the occurrence of clayey soils.

A typical underdrain bioretention area consists of (1) grass/gravel filter strip at the entrance, (2) ponding area, (3) native vegetation selected for tolerance to wet and dry conditions, (4) hardwood mulch layer, (5) planting soil layer amended to promote infiltration, (6) pea gravel diaphragm, (7) underdrain with outlet, and (8) overflow structure. ^[3] Premanufactured bioretention boxes are also available.

Properly designed, constructed and maintained bioretention areas have demonstrated excellent pollutant load removal. However, pollutant removal drastically declines when poorly designed or not sufficiently maintained. Information on pollutant removal by bioretention areas may be found in the National Pollutant Removal Performance Database, 2nd Edition (www.cwp.org) and the National Stormwater Best Management Practices (BMP) Database (www.bmpdatabase.org).

Native vegetation is preferred for use in bioretention areas. Ideally, native plant species should require less maintenance and provide better wildlife habitat than introduced species. Exotic invasive species should never be used and should be removed during annual maintenance.

Bioretention areas should be finished “last” during the construction phase to minimize sediment delivery to the bioretention facility.

- The non-engineered version of this practice is a Rain Garden and is not included in the Bioretention Area of this handbook, but is covered in the Low Impact Development Handbook for the State of Alabama [1].

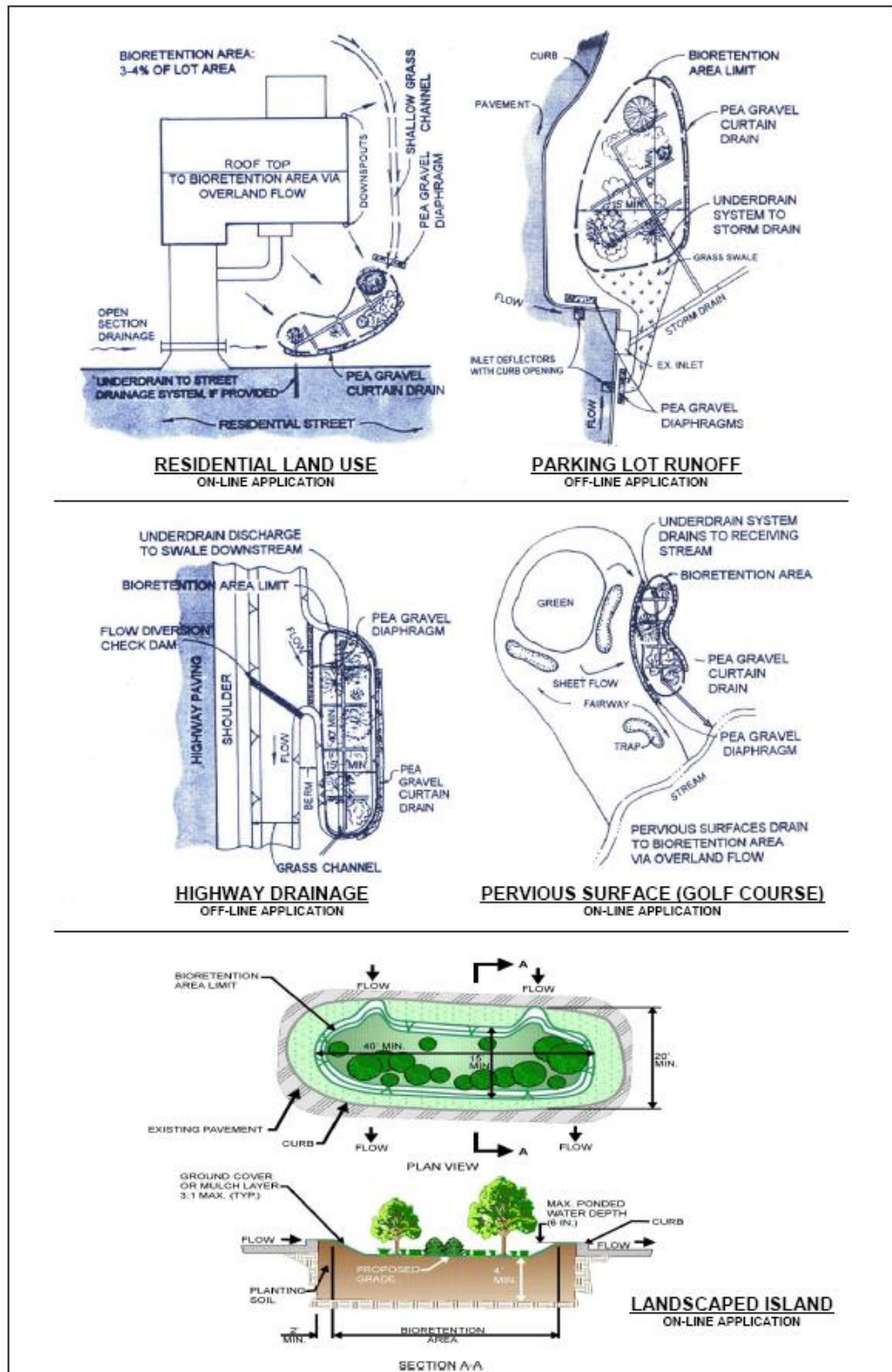

Figure BA-1 Applications of Bioretention Areas
(Source: Claytor and Schueler, 1996. Center for Watershed Protection.)

Design Criteria

Drainage Area

The drainage area contributing runoff to a bioretention area should be at maximum 5 acres and preferably between 0.5 and 2 acres. ^[2]

Slopes

Slopes in the bioretention area should be flatter than 6%. ^[2]

Space Required

A bioretention area requires approximately 5% of the impervious portion of its drainage area. A minimum area of 200 ft² (10 ft. x 20 ft.) is recommended for small sites. ^[2]

Water Table

A distance of 2 feet between the bottom of the bioretention basin and the seasonal high-water table is recommended. If a bioretention area is installed at a potential stormwater pollutant hotspot, e.g. gas station or in karst topography, an impermeable liner should be installed to prevent runoff from potentially reaching and polluting an aquifer. ^[2]

In-situ Soils for No-Underdrain Design

In-situ soils should have an infiltration rate greater than 1” per hour for a no-underdrain bioretention area design. ^[3]

Soil Mixtures

The volumetric soil mixture for the bioretention area should consist of 85% washed sand, 3-5% organic (mulch, non-animal waste compost or peat moss) and 8-12% fines (silt and clay).

The planting soil for the bioretention soil mixture should be equivalent to loamy sand or sandy loam. Soil testing is recommended to determine fertilizer and lime needs. Proper soil fertility and pH is essential to support vigorous plant growth and to enhance pollutant removal.

Plant Materials

Plants should be tolerant of both extreme wet and dry conditions and include a mixture of evergreen and deciduous vegetation. Publications, such as the Low Impact Development Handbook for the State of Alabama ^[1] and Residential Rain Garden Handbook ^[5] by the Alabama Cooperative Extension System provide a listing of adapted species used in the region. The Alabama Cooperative Extension System specialists trained in bioretention technology can also provide plant selection guidance.

Facility Specifications

Minimum dimensions of a bioretention area are 10 feet wide by 20 feet long. Wherever possible, sites should have a minimum length to width ratio of 2:1. The planned ponding depth above the facility bottom should be 6 inches. The planting soil layer should have a minimum depth of 2 feet. Runoff should be pretreated before entering the facility by providing a grass filter strip with a gravel diaphragm (see Figures BA-2 and BA-3). The recommended organic mulch layer is 3 inches of double shredded hardwood bark.

Stone for the diaphragm should be ASTM D 448 coarse aggregate size No. 6 or No. 57.

The underdrain system is 6-inch diameter perforated plastic pipe or tubing such as that conforming to ASTM F 405 (corrugated PE tubing) or ASTM F 758 (smooth wall PVC underdrain pipe). Perforations for PVC pipe should be 4 rows of 3/8-inch diameter holes, with holes spaced at a maximum of 6 inches along the row. Perforations should be located in the lower 1/2 of the pipe circumference. The minimum grade of the pipe is 0.5%. Underground pipes should be spaced at a maximum of 10 feet on center. See Figures BA-2, BA-3 and BA-4 for schematic representations of designs.

Outlet Structures

An outlet pipe should connect the underdrain system to a storm sewer outlet. When outlets empty into a drainage structure, the outlet pipe should be positioned a minimum of 6 inches above normal flow level and covered by a minimum of 18 inches of fill.

Emergency (Auxiliary) Spillway

Overflows from a bioretention area shall be diverted by an overflow structure and a stabilized overflow channel to a stable swale or other stable waterway. The inlet of the overflow system is placed in the bioretention area and is placed 6 inches above the mulch layer (see Figure BA-2).^[2]

Maintenance

Bioretention areas must be kept accessible for inspection and maintenance.

Caution should be exercised during the application of fertilizers and pesticides in and around the bioretention area to prevent the possibility of surface and ground water contamination.

Landscaping

Proper attention to landscaping is vital to the performance of a bioretention area. Diversity of vegetation structure may include small trees, shrubs, and herbaceous vegetation. Using combinations of small trees, shrubs or

herbaceous vegetation is aesthetically pleasing and offers different levels of pollutant removal. Woody plants should not be placed near the facility inflow.

Design Procedures

Designs must be quite site-specific because of the variability in site conditions including soils, topography, use of the land in the drainage area, space for the facility and desired appearance of the facility. Because of these variables, no additional design procedures are provided. Instead, one should refer to other references^{1,2,3} for more details.

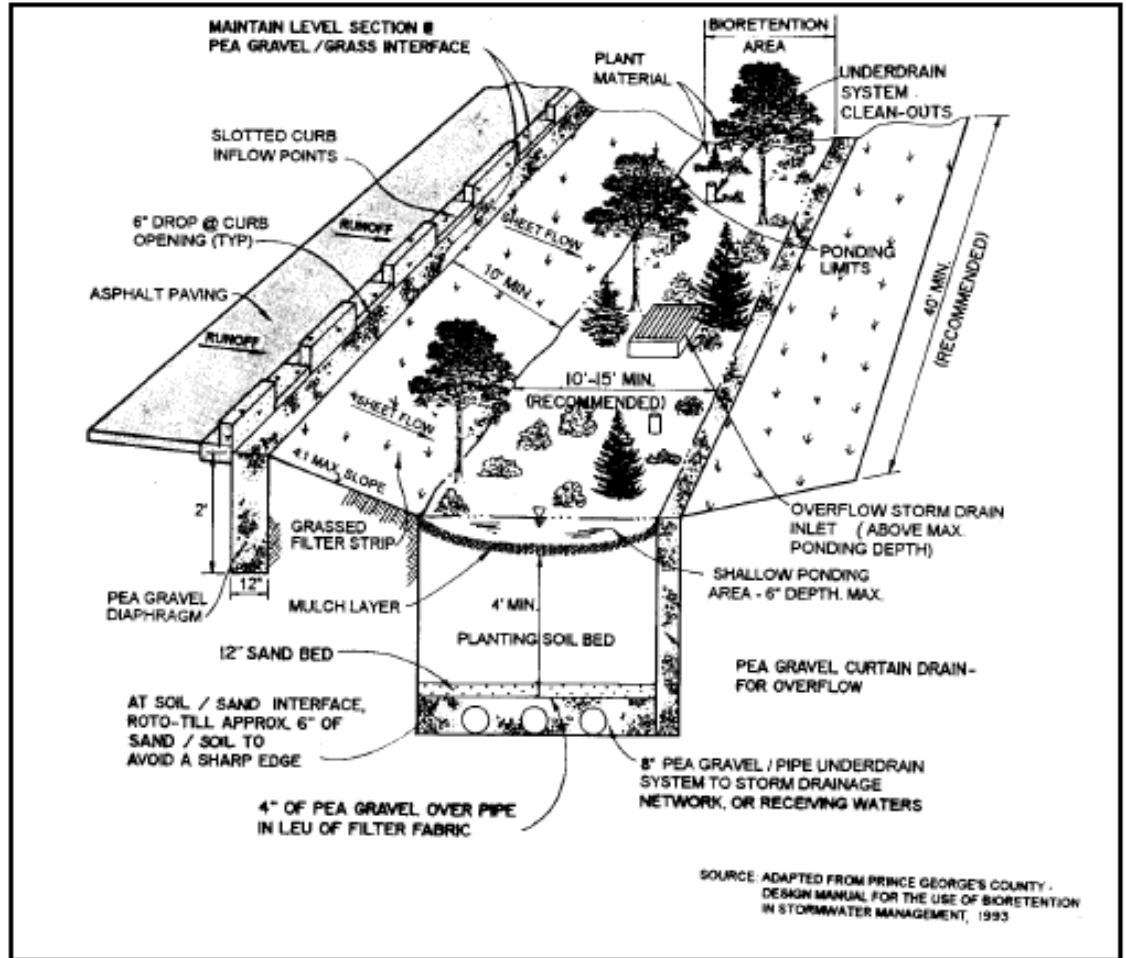

Figure BA-2 Typical Bioretention Area
 (Source: Claytor and Schueler. 1996. Center for Watershed Protection.)

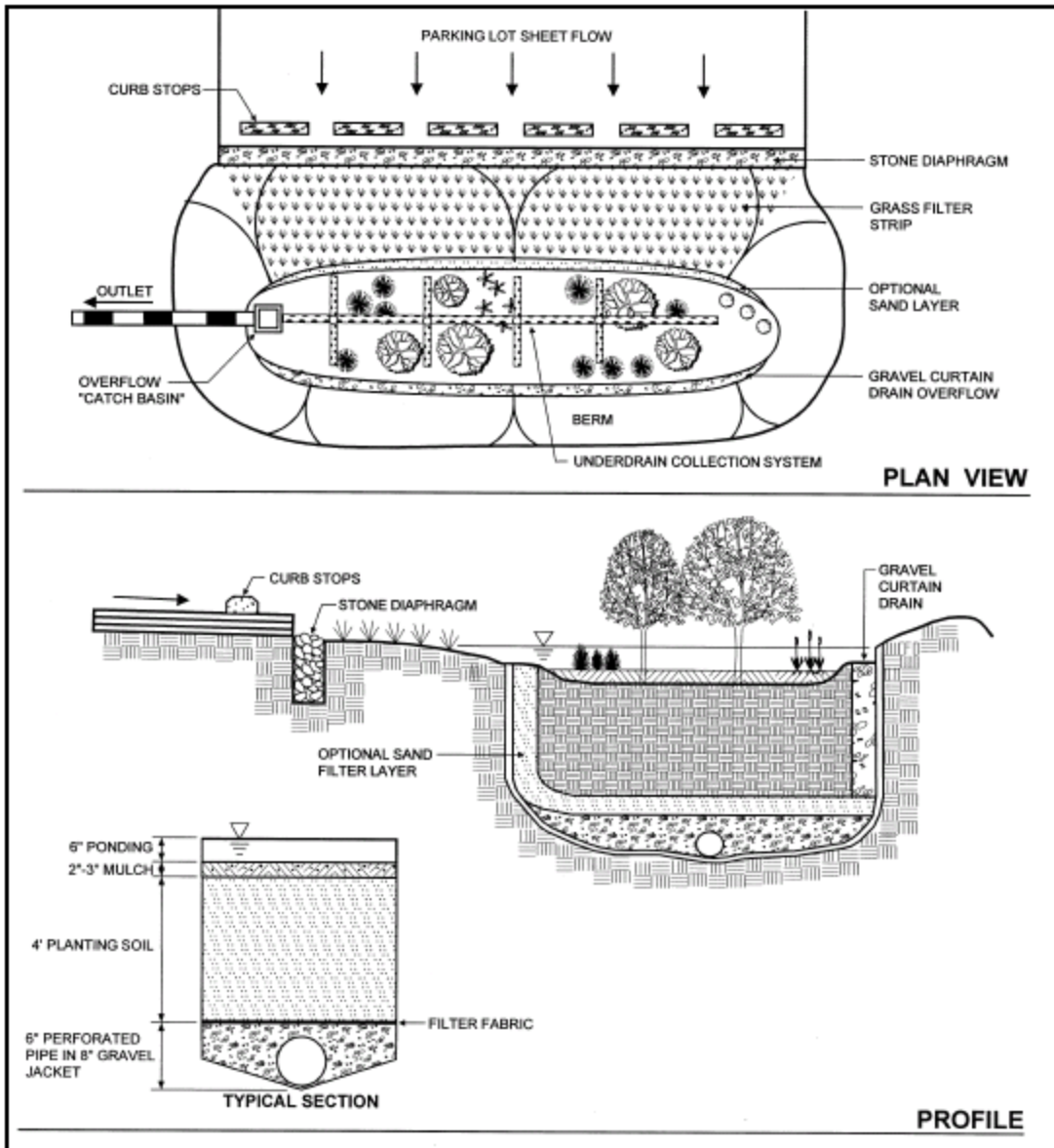

Figure BA-3 Typical On-line Bioretention Facility
 (Source: Claytor and Schueler, 1996. Center for Watershed Protection.)

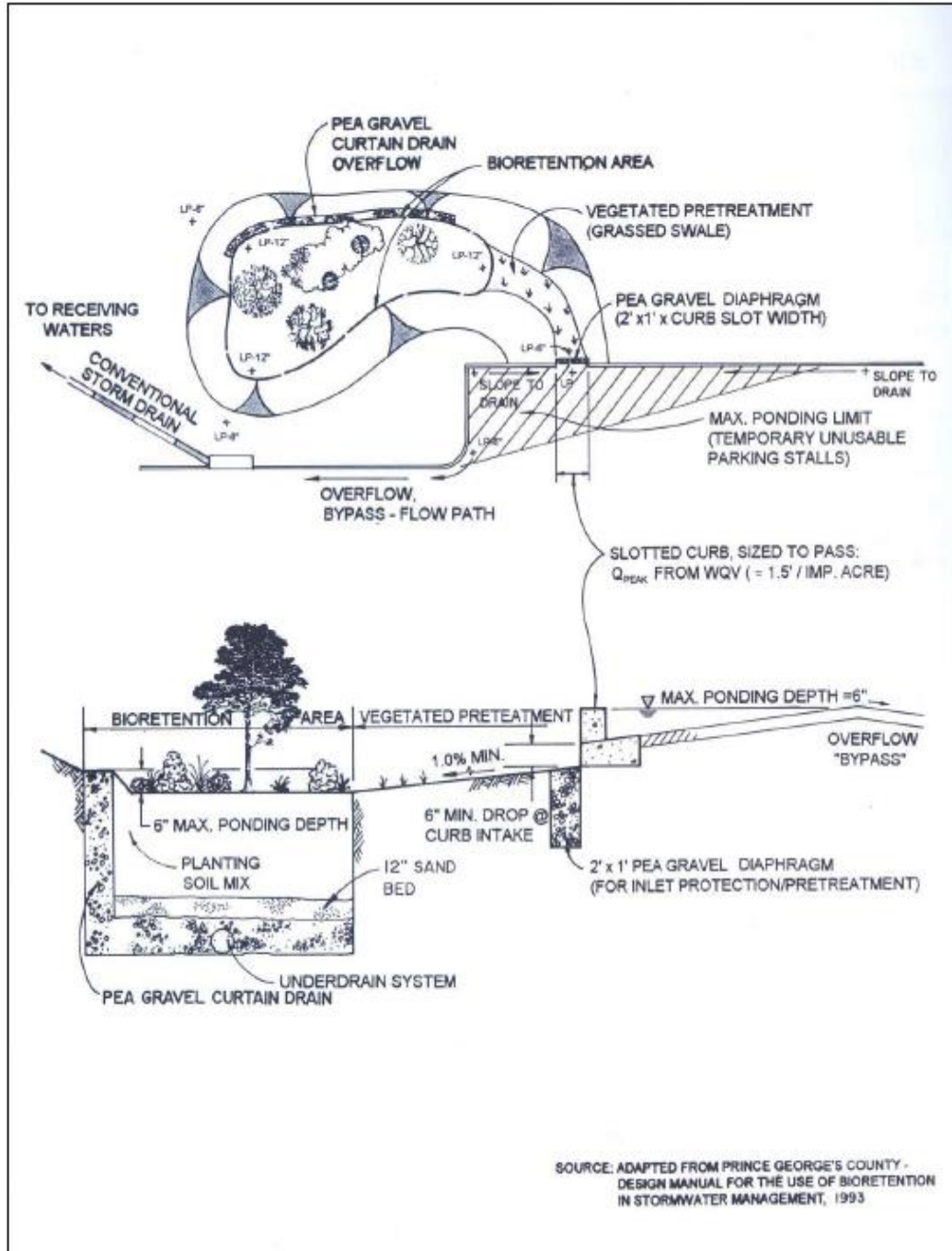

Figure BA-4 Typical Off-line Bioretention Facility
 (Source: Claytor and Schueler. 1996. Center for Watershed Protection.)

References

- [1] Low Impact Development Handbook for the State of Alabama. Alabama Department of Environmental Management, Alabama Cooperative Extension System and Auburn University, <https://adem.alabama.gov/programs/water/waterforms/LIDHandbook.pdf>
- [2] Georgia Stormwater Management Manual, Volume 2 – Technical Manual. Section 3.2.3 Bioretention Areas
- [3] The Bioretention Manual. Prince George’s County, Maryland
- [4] Drainage-Bioretention Specifications website. Low-Impact Development Center
- [5] Residential Rain Garden Handbook, Alabama Cooperative Extension System,
- [6] Claytor, R. and T. Schuler. 1996. Design of Stormwater Filtering Systems. Center for Watershed Protection. Ellicott City, MD.

This Page Intentionally Left Blank

Porous Pavement (PP)



Practice Description

Porous pavement is a permeable load-bearing layer that reduces runoff by providing infiltration and can be underlain by a stone reservoir for stormwater storage. The practice is applicable for areas with low traffic, such as overflow parking lots and lightly used access roads that are on relatively gentle slopes and permeable soils.

Concrete grids, modular pavement, or similar products will be considered as a part of this practice.

Note: Only general guidance is provided for this practice. More specific information can be obtained from the Alabama Low Impact Development (LID) Handbook.

<https://adem.alabama.gov/programs/water/waterforms/LIDHandbook.pdf>

Planning Considerations

The practice with a stone reservoir is designed to intercept storm runoff and allow it to gradually infiltrate into the subsoil. In addition, porous pavement may provide groundwater recharge, augment low flow in streams during dry periods, reduce downstream flooding and protect water quality.

Porous pavement falls into three different categories based on the extent of storage provide by the stone reservoir: a full exfiltration system (stores the entire design storm), a partial exfiltration system (stores a portion of the design storm) and a

water quality exfiltration system (provides infiltration only or stores the first flush or some portion of a design storm and conveys the excess runoff to a conventional stormwater management facility).

This practice provides protection of water quality by reducing stormwater runoff through infiltration and/or storage in a buried stone reservoir. The practice is intended for areas with relatively flat slopes (less than 5%) where traffic volumes are low and the on-site soils are permeable. The practice also requires a higher degree of maintenance than normal paving materials.

When considering use of this practice the type and amount of traffic traversing the pavement must be considered. Soils and topography of the finished paving are also important. Since various levels of storage can be used, the area available for underground storage, as well as outlets for the storage area, needs to be considered in the design of the system. The seasonal high-water table is an important consideration in the design of the stone storage reservoirs.

Design Criteria

Drainage Area

The drainage area contributing runoff to the stone storage reservoir should be between $\frac{1}{4}$ and 10 acres.

Slopes

Slopes in the area to receive porous paving should be flatter than 5%.

Pavement Thickness

If permeable asphalt is used the pavement thickness should be 2 to 4 inches. When using permeable concrete, the thickness should be 4 to 6 inches. The thickness of concrete grids or modular pavers will be determined by the thickness of the product selected that is available from the manufacturer.

Water Table

This practice should be used in areas with deep water tables. As a minimum the seasonal high-water table should be below the planned bottom of the stone storage reservoir.

Soils

Soils at the site where porous pavement is to be used should be permeable soils with combined silt/clay contents of less than 40%. Soils would generally be in NRCS hydrologic groups A, B, or C.

Stone Reservoir

The stone reservoir should be installed with a minimum of 2 feet (preferably 4 feet) of clearance between the bottom of the reservoir and bedrock. The stone reservoir should be designed so that it can be drained within 72 hours (see Figures PP-1 and PP-2).

Site Protection

Design of the porous pavement site should include measures to protect the site from being compacted by construction equipment and from erosion and sediment. Only tracked construction equipment should be used on the construction of the porous pavement subgrade. Construction traffic access routes should be routed around the site to prevent compaction by unnecessary traffic over the site. Diversions should be installed around the area to keep off-site runoff and sediment away from the site.

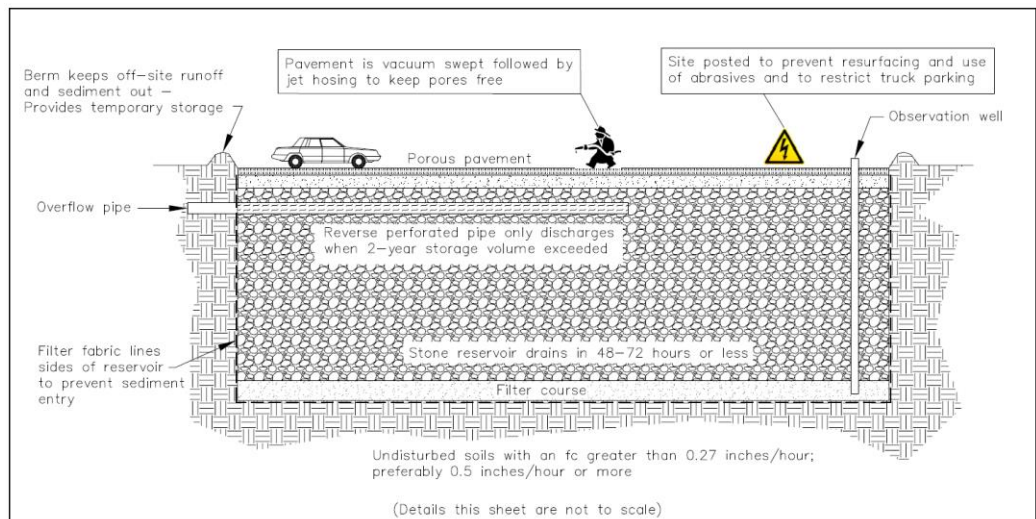

Figure PP-1 Typical Section of Porous Pavement with Buried Stone Reservoir

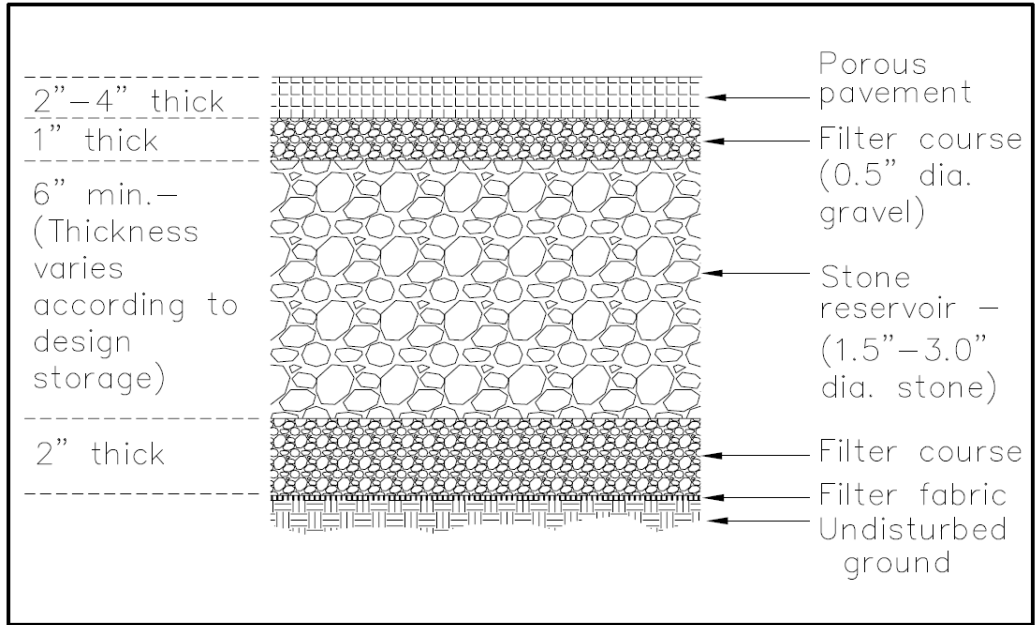

Figure PP-2 Typical Porous Pavement Design

Stormwater Detention Basin (SDB)



Practice Description

A stormwater detention basin is a dam-basin practice designed to hold stormwater runoff and release the water slowly to prevent downstream flooding and stream erosion. The practice is an extremely effective water quality and peak discharge reduction measure. Its usage is best suited to larger, more intensively developed sites. Structure life is 10 years or more. A stormwater detention basin can have a permanent pool of water or be designed to have a dry basin (typical). A detention basin can be designed to also serve as a sediment basin during the construction period.

Planning Considerations

The purpose of a stormwater detention basin is to intercept stormwater runoff and to protect drainageways, properties, and rights-of-way downstream of the structure. A qualified design professional engineer with expertise in hydrology and hydraulics should always design stormwater detention basins. This practice applies only to permanent basins on sites where:

- Failure of the dam will not result in loss of life; in damage to homes, commercial, or industrial buildings, main highways, or railroads; or in interruption of the use or service of public utilities.
- The peak release rate of stormwater runoff from the design storm does not exceed the predevelopment runoff rate for the drainage area or the rate allowed by local ordinances, whichever is less.

- The drainage area does not exceed 50 acres. The peak flow through the principal spillway normally should not exceed 50 cfs. Structures should be designed as water impoundment structures utilizing inflow hydrographs, storage characteristics of the basin, and outflow hydrographs in the design process. Design criteria should be commensurate with the complexity of site conditions, including consideration of damages that would be caused by breaching of the embankment by overtopping.

A stormwater detention basin is appropriate where physical site conditions or land ownership restrictions preclude the installation of other stormwater measures to adequately control runoff. Where site conditions are suitable, low impact practices should be strongly considered to reduce the volume of stormwater runoff. The basin should be maintained throughout the life of the development which produced the need for the basin.

When a stormwater detention basin is retrofitted as a sediment basin during the construction phase of a project, refer to the practice Sediment Basin for details of the design.

Design Criteria

Classification

Table SDB-1 shows the recommended design and classification criteria for three types of Stormwater Detention Basins.

Table SDB-1 Stormwater Detention Basin Classification

Type ¹	Max. W/S Size (acre)	Max. Dam Ht. ² (feet)	Minimum Principal Spillway Design Storm Frequency ³	Minimum Emergency (Auxiliary) Spillway Design Storm Frequency ³	Freeboard ⁴ (feet)
1	20	7	5-yr 24-hr	10-yr 24-hr	1.0
2	20	10	5-yr 24-hr	10-yr 24-hr	1.0
3	50	15	10-yr 24-hr	25-yr 24-hr	1.0

¹ Type 1 basins may be used where site conditions prevent the construction of an auxiliary spillway on residual earth.

² Height is measured from the top of the dam to the low point on the original centerline survey of the dam.

³ Runoff should be determined by NRCS methods or other methods accepted by local ordinances. Soil and cover conditions used should be based on those expected during the construction period.

⁴ Vertical distance between basin water surface at maximum flow through the auxiliary spillway and top of dam.

Location

Locate the stormwater detention basin to obtain the maximum storage benefit from the terrain and for ease of cleanout of trapped sediment. It should be located to minimize interference with construction activities and construction of utilities. Whenever possible, locate detention basins out of floodplain areas and never in flowing streams. Detention basins can be an excavated basin type as well as an earthfill dam type or a combination of the two.

Entrance of Runoff into Basin

Protect the entrance points of surface runoff into the basins to prevent erosion of the basin walls. Install riprap check dams, grade stabilization structures, or other water control devices at main points of inflow to ensure direction of runoff and protect the points of entry into the basin. Locate points of entry to ensure maximum travel distance of runoff water through the basin to the point of exit from the basin.

Erosion and Sedimentation Control

Conduct construction operations in such a manner that erosion and sedimentation will be minimized. Comply with state and local laws concerning pollution abatement.

Safety

Stormwater detention basins should comply with any state laws related to Dam Safety.

Stormwater detention basins are attractive to children and can be very dangerous. Local ordinances and regulations must be adhered to regarding health and safety. The developer or owner should check with local building officials on applicable safety requirements. If fencing of basins is required, the location of and type of fence should be shown on the plans.

Storage

The minimum capacity of a stormwater detention basin below the crest of the principal spillway pipe should be $\frac{1}{2}$ inch per acre of the potential disturbed portion of the drainage area plus the runoff volume from a 2-year frequency, 24-hour duration storm for the developed conditions.

Shape of the Basin

Design the stormwater detention basin to have a flow length to width ratio of 2:1 or greater, where flow length is the distance between the point of inflow and the point of outflow.

When the basin is used as for sediment control during construction, design the sediment storage portion of the basin to meet the requirements in the *Sediment Basin* practice.

Principal (Pipe) Spillway Design

Layout

The spillway should consist of a vertical riser joined at its bottom to a conduit (barrel) which extends through the embankment. Connections should be watertight.

Capacity

The maximum capacity of the pipe spillway should not exceed the peak rate of runoff from the drainage area in its pre-developed condition for all rainfall events up to and including the principal spillway design storm frequency. The minimum inside diameter of the barrel should be 8 inches. The diameter of the vertical inlet riser should be a minimum of 1.5 times greater than that of the barrel to ensure full barrel flow. Size the pipe to remove at least 50% of the runoff volume of the design storm within a 3-day period.

Inlet Data

The vertical inlet (riser) may be one of the following:

- A full round pipe.
- A half round pipe fitted for flashboards.
- A box-type riser fitted with flashboards.

Set the crest of the riser inlet at an elevation to provide the minimum storage requirement (runoff from a 2-year 24-hour storm for developed conditions and ½” sediment storage for the disturbed acreage). The riser should have a base (ballast) of sufficient weight to provide a 1.5:1 safety factor against flotation. Install an approved trash rack and anti-vortex device securely on top of the riser.

Anti-seep Collars

Install anti-seep collars around all conduits through earth fills according to the following criteria:

- Collars should be placed to increase the seepage length along the conduit by a minimum of 15 percent of the pipe length located within the saturation zone.
- Collar spacing should be between 5 and 14 times the vertical projection of each collar.
- All collars should be placed within the saturation zone.
- All anti-seep collars and their connection should be watertight.

A properly designed filter diaphragm may be utilized and should be preferred in lieu of anti-seep collars (See NRCS National Engineering Chapter 45 – Filter Diaphragms for design procedures).

Outlet

Provide protection of the barrel pipe outlet where needed to prevent outlet scour. Design outlet protection measures according to the *Outlet Protection Standard*.

Dewatering the Basin

Stormwater detention basins can serve a dual purpose as a sediment basin during construction and a stormwater detention basin after construction (See Figure SDB-1). Basins that serve only for stormwater detention can be designed as either a dry pool (typical) or a wet pool (See Figures SDB-2 and SDB-3).

For basins designed to also serve as a sediment basin, dewatering the sediment basin volume ($\frac{1}{2}$ " runoff for the disturbed acreage plus $\frac{1}{2}$ " runoff for the total drainage area) is best accomplished with a skimmer designed according to the *Sediment Basin* practice design criteria. Dewatering of the 2-year developed condition runoff above the sediment basin volume can be accomplished with a small 4-inch orifice (installed with trash protection) in the riser at the sediment storage elevation. After disturbed areas contributing runoff water to the basin have been stabilized, the skimmer dewatering device can be removed to allow the basin to operate only as a stormwater detention basin. If the purpose of the basin is to also treat the "first flush", the skimmer can be left as a permanent treatment measure. Any accumulation of sediments that would reduce stormwater detention storage should be removed and disposed of in a proper manner.

Dry basins that serve only as stormwater detention can be dewatered with a 4" orifice (installed with trash protection) at the base of the riser.

Emergency (Auxiliary) spillways

Layout

Install earth emergency (auxiliary) spillways for Type 2 and 3 basins only in undisturbed earth. Auxiliary spillways for Type 1 basins may be located on compacted earth fill selected for erosion resistance qualities. Other erosion control measures such as rock riprap may be required to ensure stable Auxiliary spillways. Each spillway should have a longitudinal level section at least 25 feet long at its crest and a straight outlet section for at least 25 feet or $\frac{1}{2}$ the base width of the embankment fill.

Capacity and Design

Spillways should be trapezoidal in cross section with minimum bottom widths of 10 feet and side slopes of 3:1. The elevation of the emergency spillway crest will

be determined through routing procedures of the principal spillway design storm. The capacity of the emergency spillway should be adequate to pass peak discharges of the emergency spillway design storm, taking into account the discharge through the principal spillway and the available storage. As a minimum, the designer should consider at least 0.5 foot of stage for flow through the emergency spillway. Spillways should be designed to pass designed discharges at non-erosive velocities for the types of protection used.

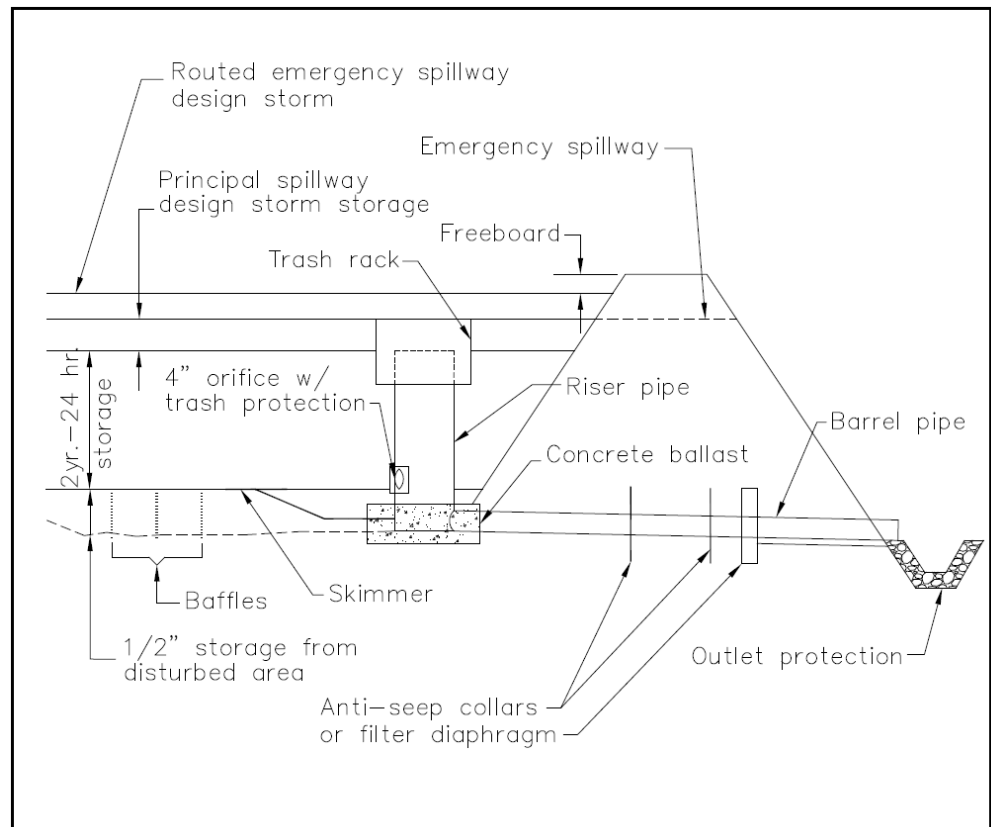

Figure SDB-1 Typical Stormwater Detention Basin / Sediment Basin Components.

Embankment

The minimum top width should be 8 feet. Side slopes should be no steeper than 2½:1 (mowable surfaces should be 3:1 or flatter). On sites where relatively impermeable material (clay) is not available for a core, the downstream side slope should be increased to 4:1. Construct a keyway along the centerline of the dam. It should be at least 8 feet wide, have 1:5:1 or flatter side slopes, and should extend at least 2 feet below the normal ground surface. The core of the embankment should be at least 8 feet wide and consist of the most impermeable material available at the site. Extend this core from the bottom of the keyway to the crest of the emergency (auxiliary) spillway.

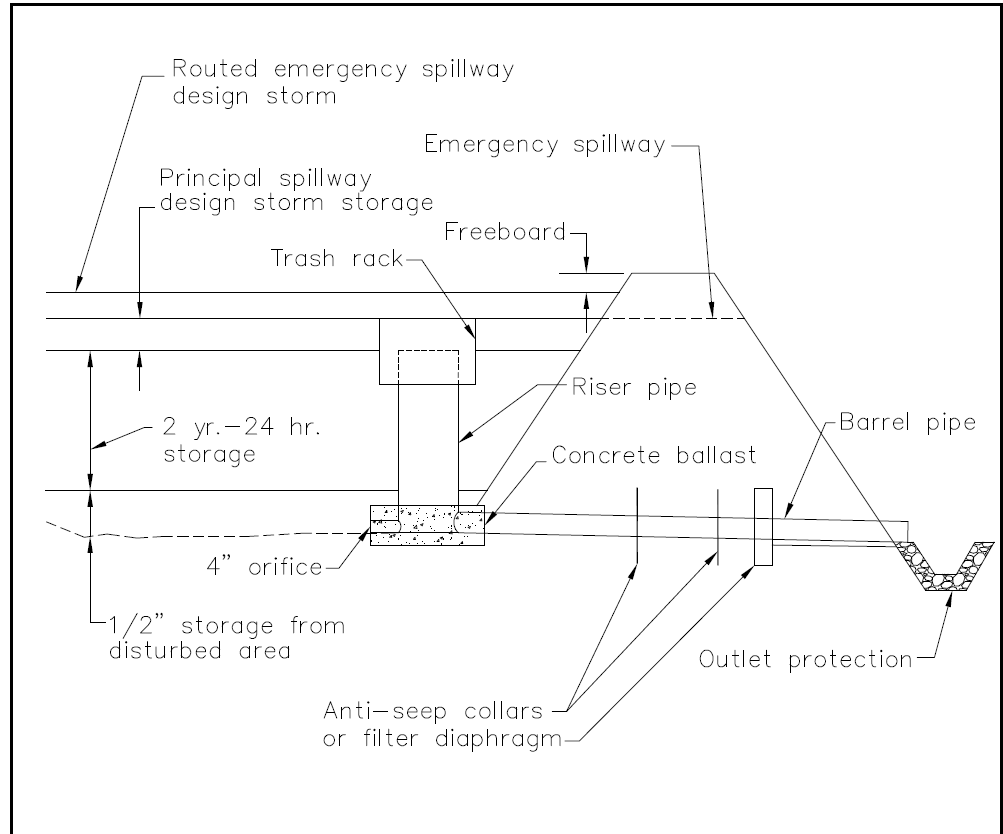

Figure SDB-2 Typical Dry Stormwater Detention Basin Components.

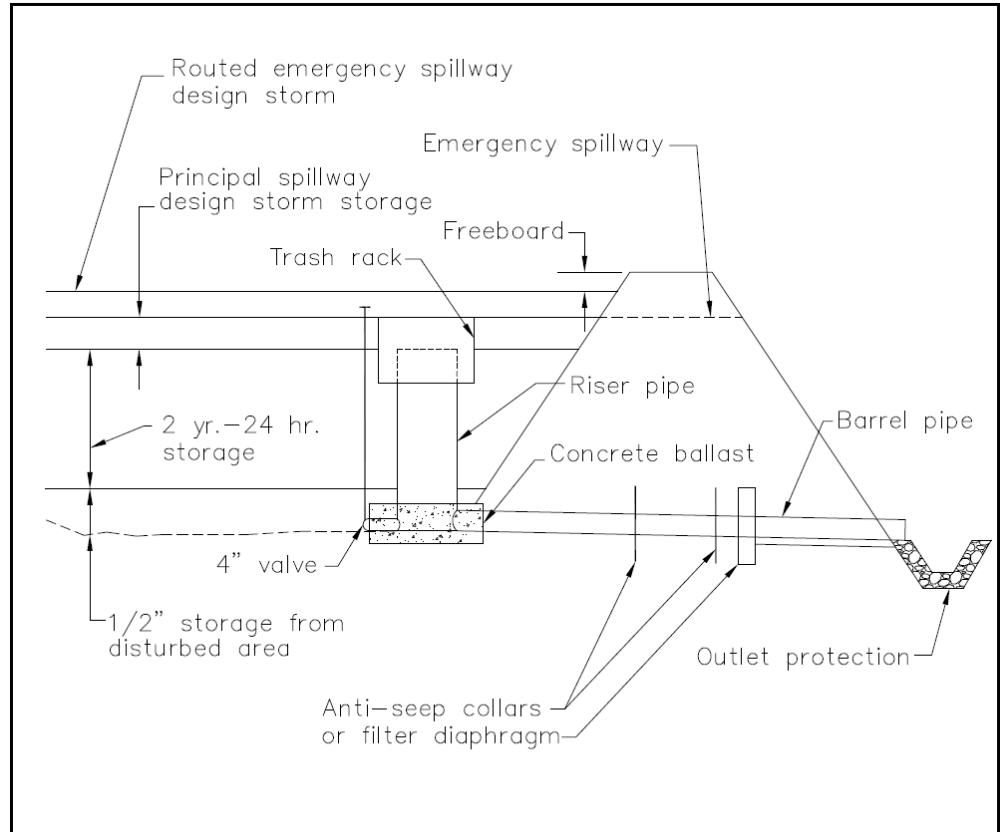

Figure SDB-3 Typical Wet Stormwater Detention Basin Components.

Buffer Zone (BZ)



Practice Description

A buffer zone is a strip of plants adjacent to land-disturbing sites bordering streams, lakes, and wetlands which provides streambank stability, reduces scour erosion, reduces storm runoff velocities, and filters sediment in stormwater. This practice applies on construction sites and other disturbed areas that can support vegetation and can be particularly effective on floodplains, next to wetlands, along streambanks and on steep, unstable slopes.

Planning Considerations

The width and plant composition of a buffer zone will determine its effectiveness.

There is no ideal width and plant community for buffer zones. The width of the buffer zone should be designed with desirable vegetation to provide significant protection of a perennial stream, water body or wetland. The purpose(s) of the buffer and landscape characteristics should determine the width of the buffer needed.

Three zones are typically recognized in the buffer area. If planned to be 45 to 55 feet wide, the recommended width and plant categories are described in the following listings:

- Zone 1: the first 15 to 20 feet nearest the stream. Cover is close growing trees (commonly 6 to 10 feet apart).
- Zone 2: the next 10 to 15 feet. Cover is trees or trees and shrubs.
- Zone 3: the next 20 feet. Cover is grass or dense groundcover.

Note: All widths are for one side of the stream only and are measured from top of stream bank.

Existing vegetation should be considered for retention, especially hardwoods that are in Zones 1 and 2.

Buffer Zone 3 may be established with a grass planting or with close-growing groundcover that will provide dense cover to filter sediment. Where topography accommodates sheet flow from the adjacent landscape, Zone 3 should be retained or developed as a Filter Strip.

Necessary site preparation and planting for establishing new buffers should be done at a time and manner to insure survival and growth of selected species.

Buffer zones may become part of the overall landscape of the project.

The layout and density of the buffer should complement natural features and mimic natural riparian forests.

Design Criteria

Installation (Preservation)

Evaluate vegetation and landscape features in proposed buffer zone to determine potential for existing plant community to maintain streambank stability, prevent sheet, rill and scour erosion, reduce stormwater velocities and filter sediment.

Dedicate a vegetated zone to effectively minimize streambank and shoreline erosion, prevent sheet, rill and scour erosion in the buffer zone and remove sediment from sheet flow from the disturbed area. Initially estimate a width of 50 feet wide adjacent to the stream (each side), water body or wetland. Adjust the width to account for slope of the land adjacent to the stream and the purposes of the buffer. If the buffer is planned to trap sediment in sheet flow the width should be increased 2 feet for every 1% slope measured along a line perpendicular to the streambank and immediately downslope of the disturbed area. If the buffer is not planned to trap sediment and only bank stabilization is the purpose of the buffer only Zones 1 and 2 are required and the adjustment for slope of the adjacent land is not essential.

Installation (Plantings)

Width and Zone Requirements

Use guidance under Installation (Preservation) to determine width and zone requirements.

Site Preparation

Plan appropriate site preparation to provide a suitable planting medium for grass, or trees and shrubs.

Plan to install sediment and erosion control measures such as silt fence and diversions if zones are graded before seedbed preparation.

If significant compaction exists, plan for chiseling or subsoiling.

For Zone 3 plantings, clear area of clods, rocks, etc. that would interfere with seedbed preparation; smooth the area, to encourage sheet flow, before the soil amendments are applied and firm the soil after the soil amendments are applied. Follow guidelines in the Filter Strip practice Design Criteria if Zone 3 is to be used to filter sheet flow from the adjacent construction area.

Soil Amendments (lime and fertilizer)

Plan soil amendments using design criteria for the appropriate category (Permanent Seeding, Tree Planting on Disturbed Areas, and Shrub, Vine and Groundcover Planting). Incorporate amendments to a depth of 4" to 6" with a disk or chisel plow.

Plantings

Plan the vegetation for buffer zones using Design Criteria for Permanent Seeding, Tree Planting on Disturbed Areas, and/or Shrub, Vine and Groundcover Planting. No invasive species shall be used. If trees are planted, multiple hardwood species should be used.

Mulching

Plan to mulch shaped areas, and other areas that are bare using the Mulching practice.

This Page Intentionally Left Blank

Channel Stabilization (CS)



Practice Description

Channel stabilization is stabilizing an open channel, either natural or artificial, in which water flows with a free surface. The purpose of this practice is to establish a non-erosive channel. This practice applies to the stabilization of open channels and existing streams or ditches with drainage areas less than 1 square mile.

Note: The design of open channel conveyance structures other than Grass Swale is beyond the scope of this edition of the Alabama Handbook and should be done by a qualified design professional and meet applicable state, federal and local regulatory requirements.

Planning Considerations

Methods of channel stabilization include rock riprap lining, concrete lining, and grade stabilization structures.

This practice applies to the improvement or stabilization of open channels and existing streams or ditches with drainage areas less than 1 square mile. Channels with drainage greater than 1 square mile will be designed with appropriate criteria. In all cases, channel stabilization design should be done by a qualified design professional experienced in hydrology and hydraulics. An adequate outlet for the channel must be available for discharge by gravity flow. Construction or other improvements to the channel should not adversely affect the environmental integrity of the area and must not cause significant erosion upstream or flooding and/or sediment deposition downstream.

The alignment and design of channels and stabilization structures shall give careful consideration to the preservation of valuable fish and wildlife habitat and trees of significant value for aesthetic purposes.

Where construction will adversely affect significant fish or wildlife habitat, mitigation measures should be included in the plan. Mitigation measures may include in-stream structures such as pools, riffles, and woody structures, or streamside measures such as trees, shrubs, and other features that enhance wildlife habitat.

Due to the varied nature of these considerations an interdisciplinary team consisting of engineers, hydrologists, and wildlife biologists should prepare the design of streambank protection for each unique channel reach. If instability is occurring over a significant length of stream the team should consider performing a geomorphic analysis of the stream. All local, state and federal laws, especially laws relating to 404 permits should be followed during the design and construction process.

Design Criteria

Realignment

The realignment of channels should be kept to an absolute minimum. Where realignment is unavoidable, the realigned channel should be designed to have a stable grade considering the soil type, vegetation, and new channel length.

Channel Capacity

The design capacity of open channels and stabilization structures should be determined by procedures applicable to the purposes to be served.

Hydraulic Requirements

Manning's formula should be used to determine velocities in channels. The "n" values for use in this formula should be estimated using currently accepted guides along with knowledge and experience regarding the conditions. Acceptable guides can be found in hydrology textbooks.

Channel Cross-Section

The required channel cross section of new or realigned channels is determined by the design capacity, the bed and bank materials, vegetation, and the requirements for maintenance. A minimum depth may be required to provide adequate outlets for subsurface drains and tributary channels. In order to enhance fisheries and wildlife, consider a channel cross section configuration that will ensure concentrated and unobstructed flow during periods of low flow.

Drop Structure

Drop structures are used to reduce or prevent excessive erosion by reduction of velocities in the watercourse or by providing structures that can withstand and reduce the higher velocities. They may be constructed of concrete, rock, masonry, steel, aluminum or non-toxic treated wood.

These structures are constructed where the capability of earth and vegetative measures is exceeded in the safe handling of water at permissible velocities, where excessive grades or overall conditions are encountered or where water is to be lowered structurally from one elevation to another. These structures should generally be planned and installed along with or as part of other erosion control practices. The structures must be designed hydraulically to adequately carry the channel discharge and structurally to withstand loadings imposed by the site conditions.

Channel Stability

All channel construction, improvement and modification should be in accord with a design expected to result in a stable channel which can be maintained.

Characteristics of a stable channel are:

- It neither aggrades nor degrades beyond tolerable limits.
- The channel banks do not erode to the extent that the channel cross section is changed appreciably.
- Excessive sediment bars do not develop.
- Excessive erosion does not occur around culverts, bridges or elsewhere.
- Gullies do not form or enlarge due to the entry of uncontrolled surface flow to the channel.
- The determination of channel stability considers “bankfull” flow.
- Bankfull flow is defined as the flow in the channel which creates a water surface that is at or near normal ground elevation for a significant length of a channel reach. Excessive channel depth created by cutting through high ground, such as might result from realignment of the channel, should not be considered in determinations of bankfull flow.

The design for channels in natural materials shall be considered stable if the check velocity is less than the allowable velocities shown in Table CS-1. The check velocity is defined as the lesser of the bankfull velocity or 10-year frequency peak discharge velocity.

Table CS-1 Allowable Velocities for Various Soil Textures

Soil Texture	Allowable Velocity (ft/sec.)
Sand and Sandy Loam (noncolloidal)	2.5
Silt Loam (also high lime clay)	3.0
Sandy Clay Loam	3.5
Clay Loam	4.0
Stiff Clay, Fine Gravel, Graded Loam to Gravel	5.0
Graded Silt to Cobbles (colloidal)	5.5
Shale, Hardpan and Coarse Gravel	6.0

Channel Linings and Structural Measures

Where channel velocities exceed safe velocities for bare soil, channel linings of rock, concrete or other durable material may be needed. Grade stabilization structures may also be needed.

Use one or more of the following methods to stabilize channels:

Rock Riprap Lining

Rock riprap should be designed to resist displacement when the channel is flowing at the bankfull discharge or the 10-year 24-hour frequency discharge whichever is the lesser. Rock riprap lining should not be used when channel velocities exceed 10 feet per second unless a detailed engineering analysis is performed using appropriate guidelines.

Use Figure CS-1 to determine the stable basic stone weight (d_{100}). Using the d_{100} size as a d_{90} , select a commercially available riprap gradation as classified by the Alabama Department of Transportation, from Table CS-2.

Dumped and machine placed riprap should be installed on slopes flatter than 2 horizontal to 1 vertical. Where riprap is placed by hand the slopes may be steeper. Stone for riprap should consist of field stone or rough unhewn quarry stone of approximately rectangular shape. The stone should be hard and angular and of such quality that it will not disintegrate on exposure to water or weathering and it should be suitable in all other respects for the purpose intended. The specific gravity of the individual stones should be at least 2.5.

A filter blanket should be placed between the riprap and base material, if needed. A filter blanket is a layer of material placed between the riprap and the underlying soil surface to prevent soil movement into or through the riprap. A filter blanket should be considered where soils have a high piping potential and/or there is significant seepage of groundwater from the bed or banks.

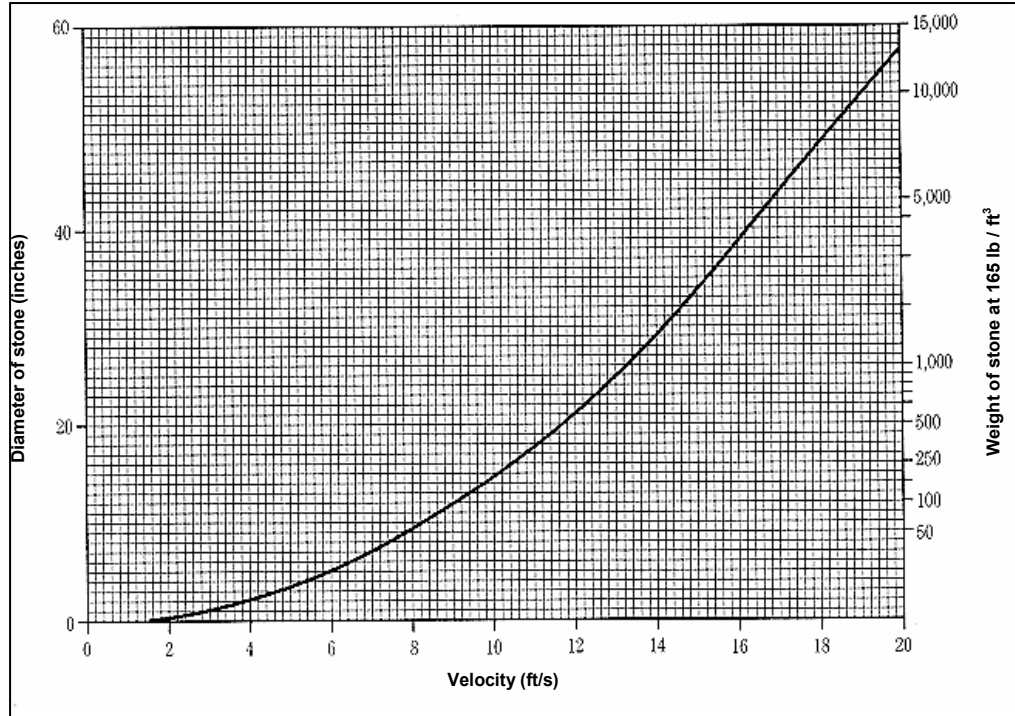

Figure CS-1 Ishbash Curve

- 1) Determine the design velocity.
- 2) Use design velocity and Figure CS-1 to determine d_{100} rock size.
- 3) Use d_{100} from Figure CS-1 as d_{90} to select rock gradation from Table CS-2.

Table CS-2 Commercially Available Riprap Gradations

Class	Weight (lbs.)					
	d_{10}	d_{15}	d_{25}	d_{50}	d_{75}	d_{90}
1	10	-	-	50	-	100
2	10	-	-	80	-	200
3	-	25	-	200	-	500
4	-	-	50	500	1000	-
5	-	-	200	1000	-	2000

A filter blanket can be of 2 general forms: a gravel layer or a geotextile filter cloth. Gravel filter blankets are to be designed in accordance with the criteria below.

The following relationships must exist:

$$(d_{15} \text{ filter} / d_{85} \text{ base}) < 5 < (d_{15} \text{ filter} / d_{15} \text{ base}) < 40$$

$$(d_{50} \text{ filter} / d_{50} \text{ base}) < 40$$

In these relationships, filter refers to the overlying material and base refers to the underlying material. The relationships must hold between the filter material and the base material and between the riprap and the filter material. In some cases, more than one layer of filter material may be needed. Each layer of filter material should be approximately 6" thick.

Non-woven geotextile filter cloth may be used in place of or in conjunction with gravel filters where appropriate as a separator between rock and soil to prevent migration of soil particles from the subgrade, through the lining material. The geotextile shall be of the strength and durability required for the project to ensure the rock and soil base are stable. Generally, the non-woven geotextile should meet the requirements found in AASHTO M288 for Class 2 separation.

Filter blankets should always be provided where seepage from underground sources threatens the stability of the riprap.

Concrete Lining

Concrete linings should be designed according to currently accepted guides for structural and hydraulic adequacy. They must be designed to carry the required discharge and to withstand the loading imposed by site conditions. Concrete linings are generally used when velocities exceed 10 ft/sec. Erosion at the outlet of concrete lined channels is generally a problem due to the high velocities. Measures should be taken to reduce the velocity and erosion potential at the outlet by use of outlet protection measures (see Outlet Protection practice).

Stream Diversion Channel (SDC)



Practice Description

A stream diversion channel is a temporary practice to convey stream flow in an environmentally safe manner around or through a construction site while a permanent structure or conveyance is being installed in the stream channel.

Planning Considerations

Construction projects often cross and impact live streams creating a potential for excessive sediment delivery into the stream. In cases where in-stream work is unavoidable, a temporary stream diversion channel should be planned. In-stream projects of this nature are subject to the rules and regulations of the U. S. Army Corps of Engineers for in-stream modifications (Clean Water Act Section 404 permit) and if applicable, ADEM CWA Section 401 water quality certification. Temporary stream diversions shall be used only on streams with a drainage area less than 1 square mile (640 acres). Detailed engineering analysis and design should be used for larger drainage areas to ensure a stable diversion channel. For sites with very small drainage areas, the designer may consider temporary blocking and overland pumping of the stream. In order to avoid crossing a live stream, the planner or designer should consider only allowing access for the construction of the permanent structure from the side opposite the stream diversion channel. At locations where access from both sides of the stream is required to construct the permanent structure in the stream channel, a Temporary Stream Crossing (TSC) may be necessary. It is best to locate this crossing either up or downstream of the stream diversion channel.

Vegetation along the existing stream channel should be left undisturbed and protected with effective sediment control practices until such time as the diversion channel is constructed and can safely convey stream flows. Construction equipment should not be allowed to operate in flowing waters and are to be operated and maintained according to the Groundskeeping (GK) practice. Excavated materials should be stockpiled away from the stream and diversion channel and protected to ensure the material does not erode and enter the stream system. The stream diversion channel should be planned and installed in such a manner and time (dry season) that the impact to fisheries and the aquatic environment is minimized. A pictorial representation of a stream diversion channel is shown in Figure SDC-1.

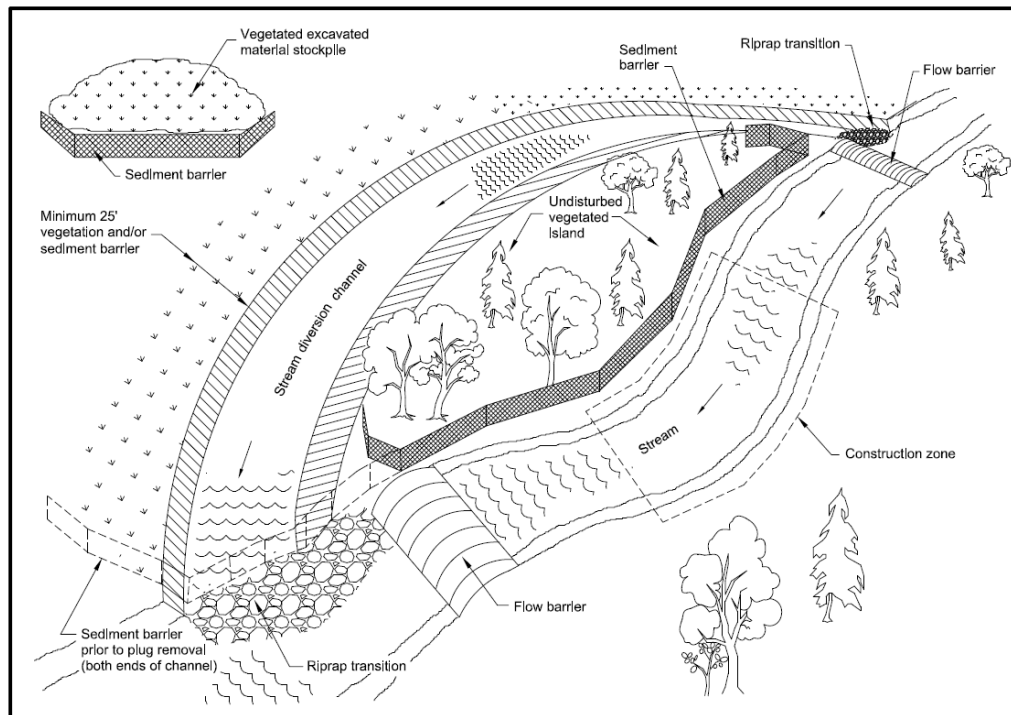

Figure SDC-1 Typical Stream Diversion Channel Layout

Design Criteria

Size

The combination of bottom width, depth, and gradient shall be sufficient to provide the required flow capacity. The minimum bottom width of the stream diversion channel shall be six feet or equal to the bottom width of the existing streambed, whichever is greater. The bottom surface should be shaped or configured to ensure adequate concentrated and unobstructed flow of water during periods of low flow.

Side Slope

Side slopes of the stream diversion channel shall be no steeper than 2 horizontal to 1 vertical (2:1).

Gradient

The diversion bottom grade may be variable, dependent on site conditions, but shall be sufficient to ensure continuous flow of water in the diversion at velocities not exceeding the allowable velocities for the selected channel lining material. The stream diversion channel length should be the same or greater than the length of the stream diverted.

Capacity

The capacity of the stream diversion channel shall be at least bankfull capacity of the existing stream. Consideration should be given to providing greater capacity where construction is expected to extend over several weeks or months.

Channel Lining

The stream diversion channel shall be lined to prevent erosion of the channel and sedimentation in the stream. The lining should be selected based on the velocity at bankfull flow. Use Table SDC-1 for general guidance on the type of lining to be used. Pre-manufactured products like turf reinforcement mats (TRM), cellular blocks, and other similar products shall be designed and installed according to the manufacturer's recommendations.

Table SDC-1 Stream Diversion Channel Linings

Lining Materials	Acceptable Velocity Range
Geotextile fabric, polyethylene film, light weight TRM, block sod	0 – 2.5 fps
Geotextile fabric, heavy weight TRM,	2.5 – 9.0 fps
Class I Riprap and Geotextile, flexible concrete lining	9.0 – 13.0 fps

Riprap linings shall be designed in accordance with the guidance contained in the Channel Stabilization (CS) practice. Non-woven geotextile shall be used underneath riprap lining for high velocity applications. Generally, the non-woven geotextile should meet the requirements found in AASHTO M288 for Class 2 separation.

When rolled products like polyethylene film or geotextile fabric are used as a channel lining, the product should be placed so that one width of material will cover the entire channel bottom and slopes while also providing enough material for a minimum 6 inch anchorage at the top of the bank. The upstream end of the material shall be buried at least 2 feet from top of bank to top of bank with additional trench anchorages of at least 1 ft. x 1 ft. at 50 foot intervals. Upstream sections of material shall overlap downstream sections by at least 2 feet and occur at a trench anchorage location. Polyethylene film shall be at least 6 mil thick and be capable of maintaining strength against the effects of ultraviolet light for a period of at least 60 days.

Block sod shall be covered with erosion control netting and staked at minimal 3 ft. x 3 ft. spacing and staked at the upstream edge of each piece of sod.

Transitions

Additional protection such as riprap may be needed at the entrance and exit portion of the stream diversion channel to ensure velocities do not scour the existing stream bed or bank.

Sequence of Construction

In order to minimize detrimental effects to the environment and the aquatic community, the stream diversion channel should be quickly and carefully installed, well maintained, and removed as soon as possible when the construction area is stable. A sequence of construction should be specified in the contract work. While the sequence of construction should be tailored to the specific site, the general process should be as follows:

- Install sediment barrier at locations alongside stream to intercept runoff from the construction of the stream diversion channel.
- Install sediment barrier around or downstream of stockpile location.
- Maintain vegetation around stream.
- Clear downstream portion of stream diversion channel except for the area of the temporary plug.
- Begin excavation of the stream diversion channel at least 25 ft. from the outlet and maintain this undisturbed plug.
- Stockpile excavated material at designated location and clear additional portions of the stream diversion channel as needed for excavation operations.
- Complete the excavation and leave at least a 25 ft. undisturbed plug at the entrance to the stream diversion channel.

- Dewater the excavated area as needed for installation of the lining and pump the dewatered material to a settling basin before any discharge is allowed.
- Install the lining in diversion channel.
- Excavate the downstream plug and install the transition riprap.
- Adjust sediment barrier locations as needed for stream protection.
- Excavate the upstream plug and install the transition riprap.
- Install an upstream flow barrier, forcing flow into the diversion channel.
- Allow time for aquatic organisms to move or migrate downstream.
- Install a downstream flow barrier if needed.
- Seed and mulch the stockpile and the disturbed area around the stream diversion channel.
- Complete the “in-stream” work.
- Divert flow into the completed “in-stream” conveyance system.
- Place sediment barriers for protection while decommissioning the stream diversion channel.
- Remove channel linings as needed, recycle or properly dispose of the material.
- Place excavated material into diversion channel
- Apply seed and mulch to disturbed areas.

This Page Intentionally Left Blank

Streambank Protection (SP)



Practice Description

Streambank protection is the stabilization of the side slopes of a stream. Streambank protection can be vegetative, structural or a combined method (bioengineering) where live plant materials are incorporated into a structure. Vegetative protection is the least costly and the most compatible with natural stream characteristics. Additional protection is required when hydrologic conditions have been greatly altered and stream velocities are excessively high. Streambank protection is often necessary in areas where development has occurred in the upstream watershed and full channel flow occurs several times a year.

Planning Considerations

Since there are several different methods of streambank protection the first step in the design process is a determination of the type protection to be used at the site. Items to consider include:

- Overall condition of the stream within and adjacent to the reach to be stabilized
- Current and future watershed conditions
- Amount of discharge at the site
- Flow velocity at the site
- Sediment load in the stream
- Channel slope
- Controls for bottom scour
- Soil conditions

- Present and anticipated channel roughness
- Compatibility of selected protection with other improvements at the site
- Changes in channel alignment
- Fish and wildlife habitat

Due to the varied nature of these considerations an interdisciplinary team consisting of engineers, hydrologists, and wildlife biologists should prepare the design of streambank protection for each unique channel reach. If instability is occurring over a significant length of stream the team should consider performing a geomorphic analysis of the stream. All local, state and federal laws, especially laws relating to 404 permits should be followed during the design and construction process.

Design Criteria

Velocities

Use vegetation alone with velocities up to 6 ft/sec if the stream bottom is stable. Use structural protection for velocities greater than 6 ft/sec. The design velocity should be the velocity associated with the peak discharge of the design storm for the channel.

Channel Bottom

The channel bottom must be stabilized before installing bank protection. Grade control in the channel bottom may be needed to prevent downcutting (see Channel Stabilization practice).

Permits

All local, state, and federal laws should be complied with during the design and construction of bank protection. If fill is to be placed in wetlands or streams the Army Corps of Engineers should be contacted regarding a 404 permit for the work.

Vegetative Protection

This practice should be used only when velocities are less than 6 ft/sec. The design team should consider the natural zones of a streambank community when selecting vegetation for use in the protection design. Native plant materials should be used for establishment and long term success. No exotic or invasive species should be used.

Aquatic Zone

This area includes the stream bed and is normally submerged at all times (See Figure SP-1). No planting is required in this zone.

Shrub Zone

This zone is on the bank slopes above mean water level and is normally dry except during floods. Plants with high root densities, high root shear and tensile strength, and an ability to transpire water at high rates are recommended for this zone. Willows, silver maples, and poplars are examples of species to use here.

Normally, grasses are not used in this area, but they can be if velocities are low and the grass will not be submerged frequently or for long periods of time.

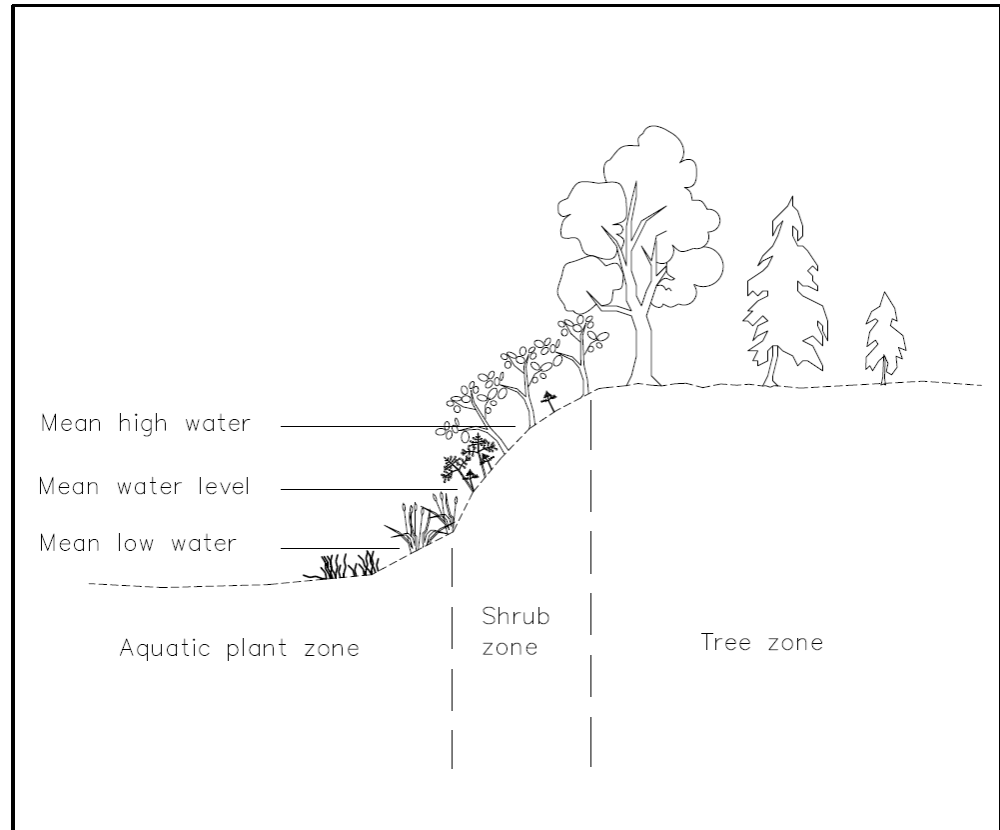

Figure SP-1 Vegetative Zones for Streambank Protection

Tree Zone

This area is at the top of the streambank. Plants in this area usually provide shade for the stream and riparian habitat for wildlife. Upland species should be planted in this location.

Structural Protection

Structural protection is used in areas where velocities exceed 6 feet per second, along channel bends, in areas with highly erodible soils and in areas of steep channel slopes. Common measures are riprap, gabions, fabric-formed revetments, tied concrete mats, and reinforced concrete.

Riprap

This is the most commonly used material for streambank protection. The following criteria should be used when designing riprap bank protection:

- Riprap should be designed to be stable under the design flow conditions using the following procedure:
 - 1) Determine the design velocity.
 - 2) Use velocity and figure SP-2 to determine d_{100} rock size.
 - 3) Use d_{100} from Figure SP-2 as d_{90} to select rock gradation from Table SP-1.
- Streambanks should be sloped at 2:1 or flatter.
- Where needed to prevent movement of soil from the channel bank into the riprap, place a geotextile filter fabric between the soil and riprap. The geotextile shall be of the strength and durability required for the project to ensure the rock and soil base are stable. Generally, the non-woven geotextile should meet the requirements found in AASHTO M288 for Class 2 separation.
- The toe of the riprap should extend a minimum of 1 foot below the stream channel bottom or anticipated scour depth to prevent failure of the riprap protection.
- The top of the riprap should extend up to the 2-year water surface elevation as a minimum unless it is determined that a lesser height in combination with vegetative measures will provide the needed protection. The remainder of the bank above the riprap can be vegetated.

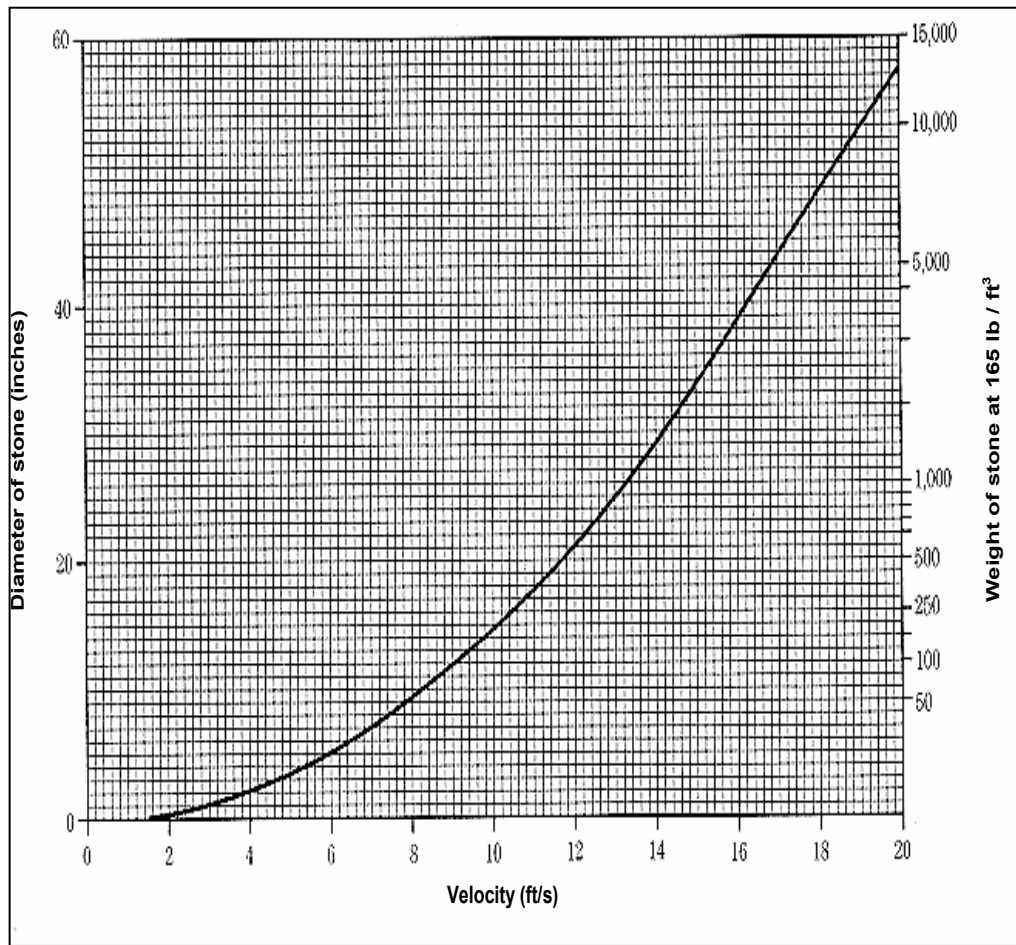

Figure SP-2 Isbash Curve

Table SP-1 Graded Riprap

Class	Weight (lbs.)					
	d ₁₀	d ₁₅	d ₂₅	d ₅₀	d ₇₅	d ₉₀
1	10	-	-	50	-	100
2	10	-	-	80	-	200
3	-	25	-	200	-	500
4	-	-	50	500	1000	-
5	-	-	200	1000	-	2000

Gabions

These rock-filled wire baskets are very labor intensive to construct, but they are semi-flexible and permeable. Gabions should be designed and constructed according to manufacturer's guidelines and recommendations. They should be filled with durable rock. If needed, a filter fabric can be used between the gabions and the soil subgrade.

Fabric-Formed Revetments

These are manufactured, large, quilted envelopes that can be sewn or zipped together at the site to form continuous coverage of the area to be protected. Once the fabric is in place, it is pumped full of grout to form a solid, hard and semi-impervious cover. Revetments should be designed and installed according to manufacturer's recommendations.

Reinforced Concrete

A qualified design professional using sound and accepted engineering procedures should design this protection method. The design should include a solid foundation for the retaining wall and a method of draining excess water from behind the wall. All structural protection methods should begin and end along stable reaches of the stream.

Combined Methods of Protection

Combinations of vegetative and structural protection can be used in any area where a structural measure would be used. Common measures include cellular matrix confinement systems, grid pavers, tied concrete mats, and bioengineering techniques. As with structural measures all combined methods should begin and end along stable reaches of the stream.

Cellular Confinement Matrices

These are commercially available products made of heavy-duty polyethylene formed into a honeycomb type matrix. The product is flexible to conform to surface irregularities. The combs may be filled with soil, sand, gravel or cement. Where soil is used to fill the combs vegetation may also be established. These systems should be designed and installed according to manufacturer's recommendations.

Grid Pavers

These are modular concrete units with interspaced voids. They are used to armor the bank and provide an area for vegetation as well. Pavers come in a variety of shapes and sizes with various anchoring methods. They should be designed and installed according to manufacturer's recommendations.

Soil Bioengineering

This method uses live, woody vegetative cuttings to increase slope stability. It can either be a woody vegetation system alone or woody vegetation combined with simple inert structures. It is especially useful in areas with minimal access or environmentally sensitive areas. Following are some general requirements for this method:

Plant Species

Use native species that root easily such as willow and are suitable for the intended use and adapted to site conditions. Plants are usually harvested from a nearby local area.

Cutting Size

Normally ½” to 2” in diameter and from 2 to 6 feet long (length will depend on project requirements).

Harvesting

Cut plant materials at a blunt angle, 8” to 10” from the ground, leaving enough trunk so that cut plants will regrow.

Transportation and Handling

Bundle cuttings together on harvest site, removing side branches. Keep material moist. Handle carefully during loading and unloading to prevent damage. Cover to protect cuttings from drying out.

Installation Timing

Deliver to construction site within 8 hours of harvest and install immediately, especially when temperatures are above 50° F. Store up to 2 days if cuttings are submerged, “heeled in” moist soil, shaded and protected from wind.

Season

Install during plants’ dormant season, generally late October to March.

Soil

Must be able to support plant growth. Compact backfill to eliminate voids and maintain good branch cutting-to-soil contact.

Woody Protective Vegetation

Live staking, live fascines, brushlayers and branchpacking are soil bioengineering practices that use the stems or branches of living plants as a soil reinforcing and stabilizing material. Eventually the vegetation becomes a major structural component of the bioengineered system.

Live Staking

Live staking is the use of live, rootable vegetative cuttings, inserted and tamped into the ground. As the stakes grow, they create a living root mat that stabilizes the soil. Use live stakes to peg down surface erosion control materials. Most native willow species root rapidly and can be used to repair small earth slips and slumps in wet areas.

To prepare live material, cleanly remove side branches, leaving the bark intact. Use cuttings ½" to 1½" in diameter and 2 to 3 feet long. Cut bottom ends at an angle to insert into soil. Cut top square. Tamp the live stake into the ground at right angles to the slope, starting at any point on the slope face. Buds should point up. Install stakes 2 to 3 feet apart using triangular spacing with from 2 to 4 stakes per square yard. An iron bar can be used to make a pilot hole in firm soil. Drive the stake into the ground with a dead blow hammer (hammer head filled with shot or sand). Four-fifths of the live stake should be underground with soil packed firmly around it after installation. Replace stakes that split during installation.

Live Fascines

Live fascines are long bundles of branch cuttings bound together into sausage-like structures. They should be placed in shallow contour trenches and at an angle on wet slopes to reduce erosion and shallow face sliding. This practice is suited to steep, rocky slopes, where digging is difficult.

To prepare live materials, make cuttings from species such as young willows or shrub dogwoods that root easily and have long, straight branches. Make stakes 2 ½ feet long for cut slopes and 3 feet long for fill slopes. Make bundles of varying lengths from 5 to 30 feet or longer, depending on site conditions and limitations in handling. Use untreated twine for bundling. Completed bundles should be 6" to 8" in diameter. Orient growing tips in the same direction. Stagger cuttings so that root ends are evenly distributed throughout the length of the bundle. Install live fascine bundles the same day they are prepared. Prepare dead stakes 2 ½ feet long, untreated 2" by 4" lumber, cut diagonally lengthwise to make 2 stakes. Live stakes will also work. Beginning at the base of the slope, dig a trench on the contour large enough to contain the live fascine. Vary width of trench from 12" to 18", depending on angle of the slope. Trench depth will be 6" to 8", depending on size

of the bundle. Place the live fascine into the trench. Drive the dead stakes directly through the bundle every 2 to 3 feet. Use extra stakes at connections or bundle overlap. Leave the top of the stakes flush with the bundle. Install live stakes on the downslope side of the bundle between the dead stakes.

Brushlayer

Brushlayering is similar to live fascine systems. Both involve placing live branch cuttings on slopes. However, in brushlayering, the cuttings are oriented at right angles to the slope contour. Use on slopes up to 2:1 in steepness and not over 15 feet in vertical height.

Starting at the toe of the slope, excavate benches horizontally, on the contour, or angled slightly down the slope to aid drainage. Construct benches 2 to 3 feet wide. Slope each bench so that the outside edge is higher than the inside.

Crisscross or overlap live branch cuttings on each bench. Place growing tips toward the outside of the bench. Place backfill on top of the root ends and compact to eliminate air spaces. Growing tips should extend slightly beyond the fill to filter sediment. Soil for backfill can be obtained from excavating the bench above. Space brushlayer rows 3 to 5 feet apart, depending upon the slope angle and stability.

Branchpacking

Branchpacking consists of alternating layers of live branch cuttings and compacted backfill to repair small localized slumps and holes in slopes (no greater than 4 feet deep or 5 feet wide). Use for earth reinforcement and mass stability of small earthen fill sites.

Make live branch cuttings from ½” to 2” in diameter and long enough to reach from soil at the back of the trench to extend slightly from the front of the rebuilt slope face.

Make wooden stakes 5 to 8 feet long from 2” by 4” lumber or 3” to 4” diameter poles. Start at the lowest point and drive wooden stakes vertically 3 to 4 feet into the ground. Set them 1 to 1½ feet apart. Place a layer of living branches 4” to 6” thick in the bottom of the hole, between the vertical stakes, and at right angles to the slope face. Place live branches in a crisscross arrangement with the growing tips oriented toward the slope face. Some of the root ends of the branches should touch the back of the hole. Follow each layer of branches with a layer of compacted soil to ensure soil contact with the branch cuttings. The final installation should match the existing slope. Branches should protrude only slightly from the rebuilt slope face.

The soil should be moist or moistened to ensure that live branches do not dry out.

Woody Vegetation with Inert Structures

Live cribwalls, vegetated rock gabions and joint plantings are soil bioengineering practices that combine a porous structure with vegetative cuttings. The structures provide immediate erosion, sliding and washout protection. As the vegetation becomes established, the structural elements become less important.

Live Cribwall

A live cribwall consists of a hollow, box-like interlocking arrangement of untreated logs or timber. Use at the base of a slope where a low wall may be required to stabilize the toe of the slope and reduce its steepness or where space is limited and a more vertical structure is required. It should be tilted back if the system is built on a smooth, evenly sloped surface.

Make live branch cuttings ½” to 2” in diameter and long enough to reach the back of the wooden crib structure. Build constructed crib of logs or timbers from 4” to 6” in diameter or width. The length will vary with the size of the crib structure. Starting at the lowest point of the slope, excavate loose material 2 to 3 feet below the ground elevation until a stable foundation is reached. Excavate the back of the stable foundation (closest to the slope) slightly deeper than the front to add stability. Place the first course of logs or timbers at the front and back of the excavated foundation, approximately 4 to 5 feet apart and parallel to the slope contour. Place the next set of logs or timbers at right angles to the slope on top of the previous set. Place each set of timbers in the same manner and nail to the preceding set. Place live branch cuttings on each set to the top of the cribwall structure with growing tips oriented toward the slope face. Backfill the cribwall, compact the soil for good root-to-soil contact, then apply seed and mulch.

Vegetated Rock Gabions

Vegetated gabions combine layers of live branches and gabions (rectangular baskets filled with rock). This practice is appropriate at the base of a slope where a low wall is required to stabilize the toe of the slope and reduce its steepness. It is not designed to resist large, lateral earth stresses. Use where space is limited and a more vertical structure is required. Overall height, including the footing, should be less than 5 feet.

Make live branch cuttings from ½” to 1” in diameter and long enough to reach beyond the rock basket structure into the backfill. Starting at the lowest point of the slope, excavate loose material 2 to 3 feet below the ground elevation until a stable foundation is reached. Excavate the back of the stable foundation (closest to the slope) slightly deeper than the front to add stability and ensure rooting. Place the wire baskets in the bottom of the excavation and fill with rock. Backfill between and behind the wire baskets. Place live branch cuttings on the wire baskets at right angles to the slope with the growing tips oriented away from the slope and extending slightly beyond the gabions. Root ends must extend beyond the backs of the wire baskets into the fill material. Place soil over the cuttings and compact it. Repeat the construction sequence until the structure reaches the required height.

Joint Planting

Joint planting or vegetated riprap involves tamping live cuttings into soil between the joints or open spaces in rocks that have previously been placed on a slope. Use where rock riprap is required. Joint planting is used to remove soil moisture, to prevent soil from washing out below the rock and to increase slope stability over riprap alone.

Make live branch cuttings from ½” to 1½” in diameter and long enough to extend into soil below the rock surface. Remove side branches from cuttings leaving the bark intact. Tamp live branch cuttings into the openings of the rock during or after construction. The root ends should extend into the soil behind the riprap. Mechanical probes may be needed to create pilot holes for the live cuttings. Place cuttings at right angles to the slope with growing tips protruding from the finished face of the rock.

This Page Intentionally Left Blank

Temporary Stream Crossing (TSC)



Photo courtesy of Steve Taylor, Auburn University Biosystems Engineering

Practice Description

A temporary stream crossing is a short term road crossing constructed over a stream for use by construction traffic to prevent turbidity and streambed disturbance caused by traffic. A temporary stream crossing can be a low water crossing, a culvert crossing, or a bridge with or without embankment approaches. Temporary stream crossings are applicable on construction sites where traffic must cross streams during construction.

Planning Considerations

A stream crossing can be an open ford, a pipe (culvert), or bridge crossing. Stream crossings can be a useful practice to provide a means for construction traffic to cross flowing streams without damaging the channel or banks or causing flooding, and to keep sediment generated by construction traffic out of the stream. Stream crossings are generally applicable to flowing streams with drainage areas less than 1 square mile. A qualified design professional should design permanent structures to handle flow from larger drainage areas.

Careful planning can minimize the need for stream crossings and the qualified design professional should always try to avoid crossing streams. Whenever possible, complete the development separately on each side and leave a natural buffer zone along the stream. Temporary stream crossings are a direct source of

water pollution; they may create flooding and safety hazards; they can be expensive to construct; and they cause costly construction delays if damaged by flooding.

Temporary stream crossings are necessary to prevent construction vehicles from damaging streambanks and continually tracking sediment and other pollutants into the flow regime. However, these structures are also undesirable in that they could cause a channel constriction, which can cause flow backups or washouts during periods of high flow. For this reason, the temporary nature of stream crossings is stressed. They should be planned to be in service for the shortest practical period of time and to be removed as soon as their function is completed.

Fords made of stabilizing material such as rock are often used in steep areas subject to flash flooding, where normal flow is shallow (less than 3") or intermittent. Fords should only be used where crossings are infrequent. Fords are especially adapted for crossing wide, shallow watercourses. Generally do not use fords where bank height exceeds 5 ft. Rock material used for the ford may be washed out during large storm events and require the rock to be replaced. Mud and other contaminants are brought into the stream on vehicles using ford crossings unless crossings are limited to no flow conditions.

The criteria contained in this practice pertains primarily to flow capacity and resistance to washout of the structure. From a safety and utility standpoint, the qualified design professional must also be sure that the structure is capable of withstanding the expected loads from heavy construction equipment. The qualified design professional must also be aware that such structures are subject to the rules and regulations of the U. S. Army Corps of Engineers for in-stream modifications (404 permits).

Design Criteria

Culvert Crossings or Spans (Bridges)

The structure should be large enough to convey the flow expected from a 2-year frequency, 24-hour duration storm without appreciably altering the stream flow characteristics. The structure may be a span or culvert. If culverts are used, see Table TSC-1 for aid in selecting the appropriate size. (Multiple culverts may be used in place of 1 large culvert if they have the equivalent capacity of the larger one). The minimum-sized culvert that may be used is 18".

Where culverts are installed (Figure TSC-1), compacted soil will be used to form the crossing. The depth of soil cover over the culvert should be equal to $\frac{1}{2}$ the diameter of the culvert or 24", whichever is greater. To protect the sides of the fill from erosion, riprap shall be used and designed in accordance with the practice Outlet Protection.

The length of the culvert should be adequate to extend the full width of the crossing, including side slopes.

The grade of the culvert pipe should be at least 0.25" per foot.

Table TSC-1 Culvert Selection Guide (pipe, diameter, inches)

Drainage Area (Acres)	Average Slope of Watershed			
	1%	4%	8%	16%
1-25	30	30	36	36
26-50	30	36	42	48
51-100	36	48	48	54
101-150	42	48	60	60
151-200	42	54	72	72
201-250	48	60	72	72
251-300	48	60	72	72
301-350	48	60	72	2X60
351-400	54	72	2X60	2X60
401-450	54	72	2X60	2X60
451-500	54	72	2X60	2X72
501-550	60	72	2X60	2X72
551-600	60	72	2X60	2X72
601-640	60	72	2X60	2X72

Assumptions for determining USDA-NRCS Peak Discharge Method; CN=70; Rainfall depth (average for Alabama) = 4.3" for 2-year/24-hour storm; No tailwater exists; and the depth of water at the inlet invert is 1.5 X diameter.

The top of the compacted fill should be covered with 6" of Alabama Highway Department course aggregate No.1 stone (3/4" to 4").

The approaches to the structure should consist of stone pads meeting the following specifications:

- Stone: Alabama Highway Department course aggregate No.1.
- Minimum thickness: 6".
- Minimum width: equal to the width of the structure.
- Minimum approach lengths: 25 feet.

Culvert crossings and spans should be designed with features that will prevent damage, destruction or removal during major flood events (i.e. cabling, emergency bypass, etc.).

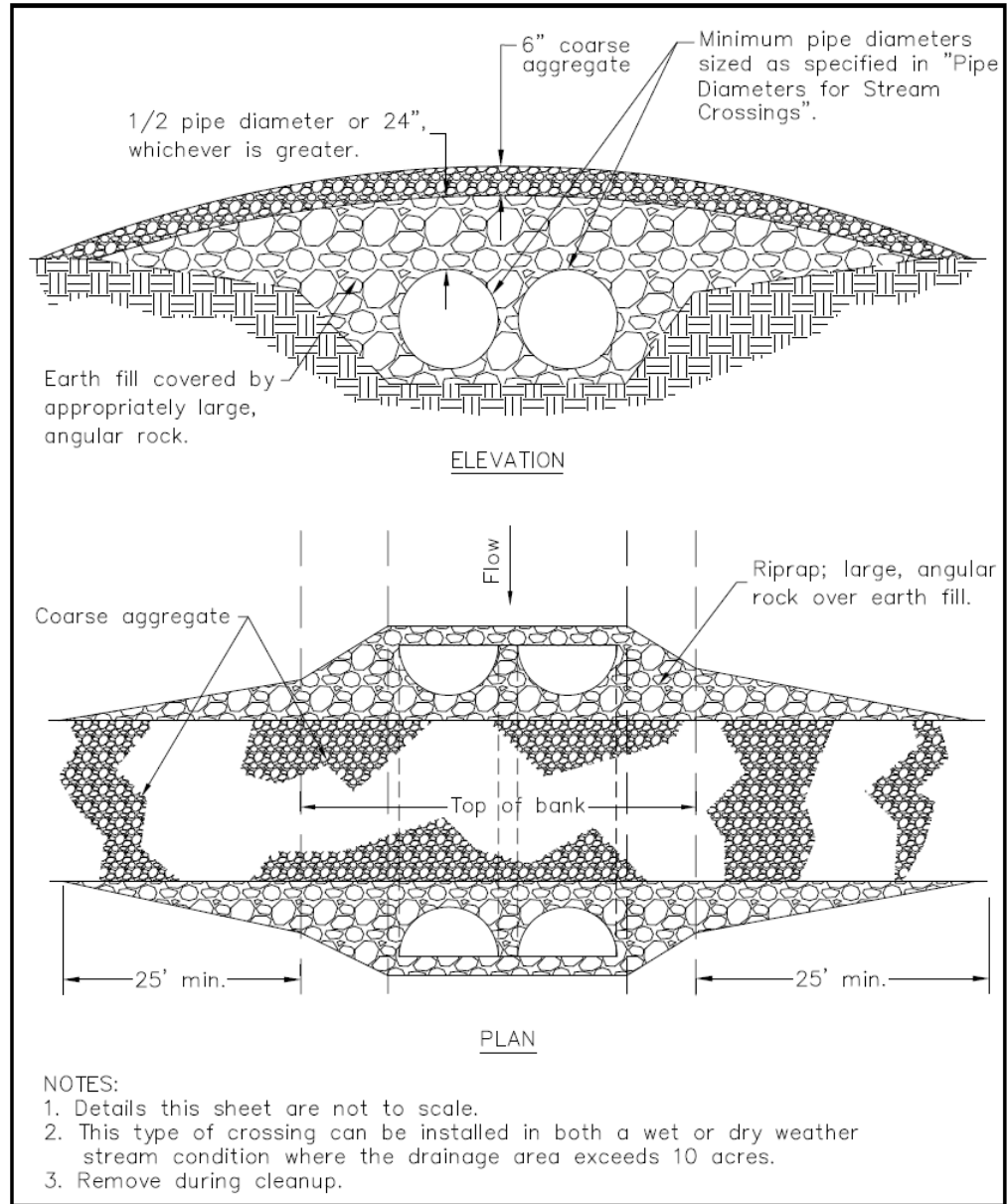

Figure TSC-1 Culvert Stream Crossing

Fords (See Figure TSC-2)

Stream banks should be excavated to provide approach sections of 5:1 or flatter.

The width of the ford crossings should be wide enough for the construction equipment to safely use.

Filter fabric material designed for use under riprap (see Channel Stabilization practice) should be installed on the excavated surface of the ford according to the manufacturer's recommendations. The fabric should extend across the bottom of the stream and at least 25 feet up each approach section. All edges of the fabric should be keyed in a minimum of 1 foot.

Alabama Highway Department course aggregate No.1 stone, 6" thick should be installed on the filter fabric and also should be used to fill the 1 foot keyed edges of the fabric.

The final surface of the stone in the bottom of the watercourse should be the same elevation as the watercourse bottom in order to eliminate any overfall and possible scour problems.

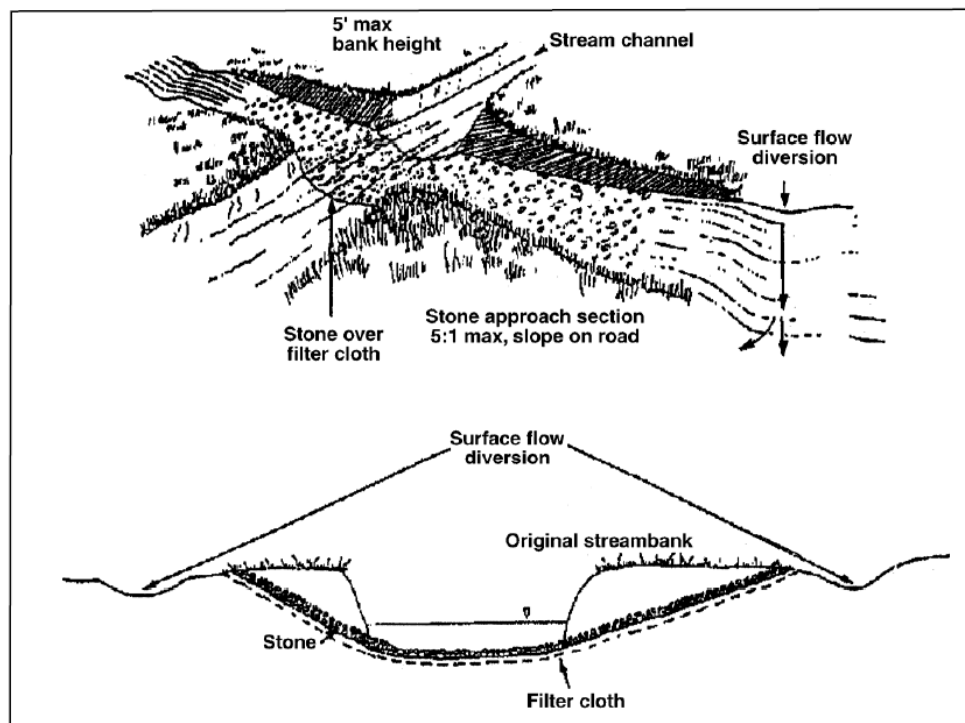

Figure TSC-2 Ford Stream Crossing

This Page Intentionally Left Blank

Appendix

Table of Contents

Soils in Alabama	1
Introduction	1
Using a Soil Survey	1
Soil Physical, Chemical, and Engineering Properties	3
Depth to Bedrock	3
Hydrologic Soil Group (HSG)	3
Saturated Hydraulic Conductivity (Ksat).....	4
Liquid Limit (LL).....	4
Plasticity Index (PI)	4
Slope.....	4
Soil Erodibility Factor(K-factor).....	4
Soil Reaction (pH)	5
Soil Texture	6
AASHTO classification	8
Unified Soil classification	9
References.....	10
Instructions for Use of Web Soil Survey for Generating Engineering, Physical & Chemical Properties of Soil	11
AASHTO M 288	22
Glossary	23
References	40
CAD Drawings	44
Local Information	46

This Page Intentionally Left Blank

Soils in Alabama

Introduction

A basic understanding of soils is essential when making erosion and sediments control management decisions. Erosion and sediment control practices along with stormwater management can be executed effectively when soil physical and chemical properties are considered throughout the planning and management phases. Information about soils within a geographic region can be obtained from the Web Soil Survey <https://websoilsurvey.sc.egov.usda.gov/App/HomePage.htm>. Soil survey information for all 67 counties within Alabama is available on the Web Soil Survey. It is highly recommended for detailed planning purposes that surveys are verified by an on-site investigation preferably performed by a professional soil scientist.

The word “Soil,” like many common words, has several meanings. The definition of Soil within this text is “a natural body comprised of solids (minerals and organic matter), liquid, and gases that occurs on the land surface, occupies space, and is characterized by one or both of the following: horizons, or layers, that are distinguishable from the initial material as a result of additions, losses, transfers, and transformations of energy and matter or the ability to support rooted plants in a natural environment” (Soil Survey Staff, 1999).

Using a Soil Survey

“A soil survey describes the characteristics of the soils in a given area, classifies the soils according to a standard system of taxonomy, plots the boundaries of the soils on a map, stores soil property information in an organized database, and makes predictions about the suitability and limitations of each soil for multiple uses as well as their likely response to management systems”. “The information collected in a soil survey helps in the development of land use plans and can be used to evaluate and predict the effect of land use on the environment” (Soil Survey Manual – Agriculture Handbook No 18).

“A soil map consists of many individual delineations showing the location and extent of different soils. A soil map from a soil survey delineates areas occupied by different kinds of soil, each of which has a unique set of interrelated properties and characteristics of the material from which it formed, its environment and its pedogenic process. The soils mapped by the National Cooperative Soil Survey staff are identified by names that serve as references to a national system of soil classification (Keys to Soil Taxonomy)”. Soils identified on a map in a soil survey are defined as soil series.

Pedon is a three-dimensional, individual unit of soil with sufficient size to describe the internal arrangement of horizons.

Soil map unit is a collection of same-named soil series plus soil and site characteristics important for land management (examples – surface texture, slope, degree of erosion, flooding and/or ponding frequencies etc.).

Soil series consist of pedons that are grouped together due to their similar morphology, soil chemistry, and physical properties. Specifically, each series consists of pedons having soil horizons that are similar in soil color, soil texture, soil structure, soil pH, mineral and chemical composition, along with other characteristics within the soil profile.

Soil surveys increase general knowledge about soils and serve for practical planning purposes. They provide soil information about specific geographic areas needed for regional or local land use planning. These plans include resource conservation for farms and ranches, development of reclamation projects, forest management, engineering projects, as well as other purposes.

The National Cooperative Soil Survey program, interpretive information is available in a public database and displayed within the Web Soil Survey (<https://websoilsurvey.sc.egov.usda.gov/App/HomePage.htm>).

Soil interpretations and/or ratings provide numerical and descriptive information pertaining to a wide range of soil interpretive predictions. Generally, soil interpretations and/or ratings are made for specified uses and are reported in the form of limitations, suitabilities, or potentials.

Limitation ratings are usually based on hazards, risks, or obstructions presented by properties or characteristics of undisturbed soil. Limitation ratings use terms such as slight, moderate, or severe (most commonly limitation ratings).

Suitability ratings are based on the characteristic of the soil that influence the ease of using or adapting a soil for a specific use. Suitability ratings classes use terms such as good, fair, or poor (most commonly suitability ratings).

Potential ratings are based on the local characteristics and/or conditions; potential rating predicts the ability for a particular soil to achieve maximum functionality based on local conditions. Potential ratings classes use terms such as high, medium, or low (most commonly potential ratings).

In addition, soil interpretations, either as suitability or limitations, may be incorporated into potential ratings along with other resource data and interpretive information. The following are some important interpretations generally used for erosion & sediment control & stormwater management planning purposes: depth to bedrock, hydrologic group, liquid limit, permeability, plasticity index, slope, soil erodibility factor (K Factor), pH, soil texture, etc.

Soil Physical, Chemical, and Engineering Properties

Below are definitions of various soil physical, chemical, and engineering properties commonly provided for Soils throughout the State of Alabama.

Depth to Bedrock

The depth to unweathered, continuous bedrock. The bedrock is commonly indurated but may also be strongly cemented, and excavation difficulty is very high or higher.

Hydrologic Soil Group (HSG)

Hydrologic soil groups are based on estimates of run-off potential. Soils are assigned to one of four groups according to the rate of water infiltration when the soils are not protected by vegetation, are thoroughly wet, and receive precipitation from long-duration storms.

The soils in the United States are assigned to four groups (A, B, C, and D) and three dual classes (A/D, B/D, and C/D). The groups are defined as follows:

Group A. Soils having a high infiltration rate (low run-off potential) when thoroughly wet. These consist mainly of deep, well drained to excessively drained sands or gravelly sands. These soils have a high rate of water transmission.

Group B. Soils having a moderate infiltration rate when thoroughly wet. These consist chiefly of moderately deep or deep, moderately well drained, or well drained soils that have moderately fine texture to moderately coarse texture. These soils have a moderate rate of water transmission.

Group C. Soils having a slow infiltration rate when thoroughly wet. These consist chiefly of soils having a layer that impedes the downward movement of water or soils of moderately fine texture or fine texture. These soils have a slow rate of water transmission.

Group D. Soils having a very slow infiltration rate (high run-off potential) when thoroughly wet. These consist chiefly of clays that have a high shrink-swell potential, soils that have a high-water table, soils that have a claypan or clay layer at or near the surface, and soils that are shallow over nearly impervious material. These soils have a very slow rate of water transmission.

If a soil is assigned to a dual hydrologic group (A/D, B/D, or C/D), the first letter is for drained areas and the second is for undrained areas. Only the soils that in their natural condition are in group D are assigned to dual classed.

Appendix

Saturated Hydraulic Conductivity (Ksat) *Permeability is an out-of-date term used in prior literature therefore, saturated hydraulic conductivity is utilized for this content.* –

The amount of water that would move downward through a unit area of saturated in-place soil in unit time under hydraulic gradient. It is used to convey the rate of water movement downward through the soil under saturated conditions (and unit hydraulic gradient).

Liquid Limit (LL)

The water content of soil at the change between liquid and plastic states. It is measured on thoroughly puddled soil material that has passed a number 40 sieve (0.43 mm) and is expressed on a dry weight basis. Values are typically placed in interpretive classes.

Plasticity Index (PI)

The range in water content over which soil material is plastic. The value is the difference between the liquid limit and plastic limit of thoroughly puddled soil material that has passed a number 40 sieve (0.43 mm). The plastic limit is the water content at the boundary between the plastic and semisolid states. Values are typically placed in interpretive classes.

Slope

The inclination of the land surface from the horizontal. Percentage of slope is the vertical distance divided by horizontal distance, then multiplied by 100. Thus, a slope of 20 percent is a drop of 20 feet in 100 feet of horizontal distance($\text{rise/run} \times 100$).

Soil Erodibility Factor (K-factor)

A relative index of susceptibility of bare, disturbed soil to particle detachment and transport by rainfall. This interpretive factor is used in the Revised Universal Soil Loss Equation (Renard et al., 1997). Measurements are made on plots of standard dimensions. Erosions is adjusted to a standard of 9 percent slope. K factors are currently measured by applying simulated rainfall on freshly tilled plots. Earlier measurements integrated the erosion for the year for cultivated plots under natural rainfall. The K factor may be computed from the composition of the soil, saturated hydraulic conductivity, and soil structure.

Soil Reaction (pH) – (see figure 1-1 – pH Chart)

A measure of acidity or alkalinity of a soil, expressed as pH values. A soil that tests to pH 7.0 is described as precisely neutral in reaction because it is neither acid nor alkaline. The degrees of acidity or alkalinity, expressed as pH values, are:

- *Ultra acid:* Less than 3.5
- *Extremely acid:* 3.5 to 4.4
- *Very strongly acid:* 4.5 to 5.0
- *Strongly acid:* 5.1 to 5.5
- *Moderately acid:* 5.6 to 6.0
- *Slightly acid:* 6.1 to 6.5
- *Neutral:* 6.6 to 7.3
- *Slightly alkaline:* 7.4 to 7.8
- *Moderately alkaline:* 7.9 to 8.4
- *Strongly alkaline:* 8.5 to 9.0
- *Very strongly alkaline:* 9.1 and higher

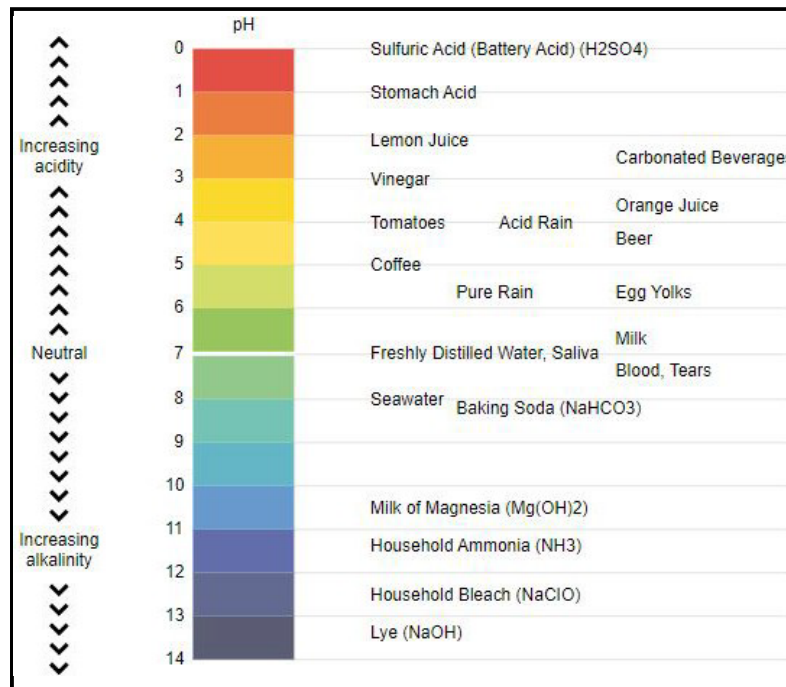

Figure 1-1. pH Chart

Appendix

USDA Soil Texture – (see figures 1-2-Texture Class; 1-3-Texture Triangle; 1-4-Texture Modifiers)

The numerical proportion (weight percentage) of the sand, silt, and clay separates in the fine-earth fraction ($\leq 2\text{mm}$). Soil texture is field estimated by hand or lab measured by hydrometer or pipette and placed within the textural triangle to obtain texture class.

Texture Class or Subclass	Code	
	Conv.	NASIS
Coarse Sand	cos	COS
Sand	s	S
Fine Sand	fs	FS
Very Fine Sand	vfs	VFS
Loamy Coarse Sand	lcos	LCOS
Loamy Sand	ls	LS
Loamy Fine Sand	lfs	LFS
Loamy Very Fine Sand	lvfs	LVFS
Coarse Sandy Loam	cosl	COSL
Sandy Loam	sl	SL
Fine Sandy Loam	fsl	FSL
Very Fine Sandy Loam	vfsl	VFSL
Loam	l	L
Silt Loam	sil	SIL
Silt	si	SI
Sandy Clay Loam	scl	SCL
Clay Loam	cl	CL
Silty Clay Loam	sicl	SICL
Sandy Clay	sc	SC
Silty Clay	sic	SIC
Clay	c	C

Figure 1-2. USDA Texture Class Chart

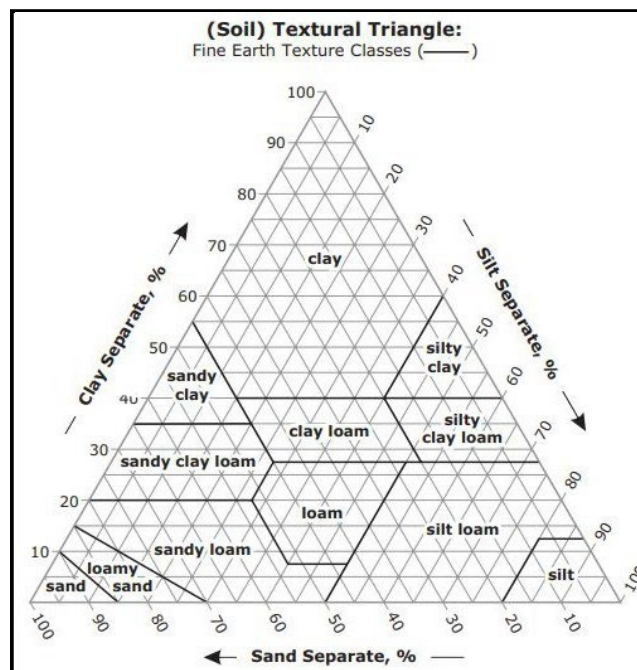

Figure 1-3. USDA Texture Triangle

Rock Fragments: Quantity and Size ¹	Code		Criteria: total (rock) fragment volume % dominated by (name size) ¹
	Conv.	NASIS	
ROCK FRAGMENTS (>2 mm; ≥ Strongly Cemented)			
Gravelly	GR	GR	≥15% but <35% gravel
Fine Gravelly	FGR	GRF	≥15% but <35% fine gravel
Medium Gravelly	MGR	GRM	≥15% but <35% med. gravel
Coarse Gravelly	CGR	GRC	≥15% but <35% coarse gravel
Very Gravelly	VGR	GRV	≥35% but <60% gravel
Extremely Gravelly	XGR	GRX	≥60% but <90% gravel
Cobbly	CB	CB	≥15% but <35% cobbles
Very Cobbly	VCB	CBV	≥35% but <60% cobbles
Extremely Cobbly	XCB	CBX	≥60% but <90% cobbles
Stony	ST	ST	≥15% but <35% stones
Very Stony	VST	STV	≥35% but <60% stones
Extremely Stony	XST	STX	≥60% but <90% stones
Bouldery	BY	BY	≥15% but <35% boulders
Very Bouldery	VBY	BYV	≥35% but <60% boulders
Extremely Bouldery	XBY	BYX	≥60% but <90% boulders
Channery	CN	CN	≥15% but <35% channers
Very Channery	VCN	CNV	≥35% but <60% channers
Extremely Channery	XCN	CNX	≥60% but <90% channers
Flaggy	FL	FL	≥15% but <35% flagstones
Very Flaggy	VFL	FLV	≥35% but <60% flagstones
Extremely Flaggy	XFL	FLX	≥60% but <90% flagstones

Figure 1-4. USDA Texture Modifiers

Appendix

AASHTO classification – (see figure 1-5 – AASHTO Chart)

An interpretive classification system of soil material for highway and airfield construction (Procedure M 145-91; AASHTO, 1997). It is based on particle-size distribution of the < 75 mm fraction and on the liquid limit and plasticity index. The system separates soil materials having 35 percent or less particles passing the no. 200 sieve (< 0.074 mm in diameter) from those soil materials having more than 35 percent. Each of these two divisions is subdivided into classification groups based on the liquid limit and plasticity index in addition to percent of particles < 0.074 mm. The group is a numerical quantity based on a set of formulas.

General classification	Granular materials (35% or less passing US No. 200 sieve)			Silt-clay materials (More than 35% passing US No. 200 sieve)							
	A-1		A-3	A-2				A-4	A-5	A-6	A-7
Group classification	A-1a	A-1b		A-2-4	A-2-5	A-2-6	A-2-7				A-7-5 A-7-6
Sieve analysis											
Percent passing											
US No. 10 (2 mm)	50 max										
US No. 40 (420 μ)	30 max	50 max	51 max	35 max	35 max	35 max	35 max	36 min	36 min	36 min	36 min
US No. 200 (75 μ)	15 max	25 max	10 max	35 max	35 max	35 max	35 max	36 min	36 min	36 min	36 min
Characteristics of fraction passing US No. 40 (420 μ)											
Liquid limit											
Plasticity index											
	6 max		Non-plastic	40 max 10 max	41 min 10 max	40 max 11 min	41 min 11 min	40 max 10 max	41 min 10 max	40 max 11 min	41 min 11 min
Group index	0		0	0		4 max		8 max	12 max	16 max	20 max
Usual types of significant constituent materials	Stone fragments gravel and sand		Fine Sand	Silty or clayey gravel and sand				Silty soils		Clayey soils	
General rating as subgrade	Excellent to good							Fair to poor			

Figure 1-5. AASHTO Chart

Unified Soil classification – (see figure 1-6 – Unified Soil Classification Chart)

An interpretive classification system of soil material designed for general construction purposes. It is dependent on particular-size distribution of the < 75 mm, liquid limit, and plasticity index and on whether the soil material has a high content of organic matter. There are three major divisions: mineral soil material having less than 50 percent particle size < 0.074 mm (passing 200 mesh), mineral soil material having 50 percent or more particle size < 0.074 mm, and certain highly organic soil materials. The major divisions are subdivided into groups based on liquid limit, plasticity index, and coarseness of the material more than 0.074 mm in diameter (retained on 200 mesh).

Major Divisions			Group Symbol	Typical Names
Course-Grained Soils More than 50% retained on the 0.075 mm (No. 200) sieve	Gravels 50% or more of coarse fraction retained on the 4.75 mm (No. 4) sieve	Clean Gravels	GW	Well-graded gravels and gravel-sand mixtures, little or no fines
			GP	Poorly graded gravels and gravel-sand mixtures, little or no fines
		Gravels with Fines	GM	Silty gravels, gravel-sand-silt mixtures
			GC	Clayey gravels, gravel-sand-clay mixtures
	Sands 50% or more of coarse fraction passes the 4.75 mm (No. 4) sieve	Clean Sands	SW	Well-graded sands and gravelly sands, little or no fines
			SP	Poorly graded sands and gravelly sands, little or no fines
		Sands with Fines	SM	Silty sands, sand-silt mixtures
			SC	Clayey sands, sand-clay mixtures
Fine-Grained Soils More than 50% passes the 0.075 mm (No. 200) sieve	Silts and Clays Liquid Limit 50% or less	ML	Inorganic silts, very fine sands, rock flour, silty or clayey fine sands	
		CL	Inorganic clays of low to medium plasticity, gravelly/sandy/silty/lean clays	
		OL	Organic silts and organic silty clays of low plasticity	
	Silts and Clays Liquid Limit greater than 50%	MH	Inorganic silts, micaceous or diatomaceous fine sands or silts, elastic silts	
		CH	Inorganic clays or high plasticity, fat clays	
		OH	Organic clays of medium to high plasticity	
Highly Organic Soils			PT	Peat, muck, and other highly organic soils
Prefix: G = Gravel, S = Sand, M = Silt, C = Clay, O = Organic Suffix: W = Well Graded, P = Poorly Graded, M = Silty, L = Clay, LL < 50%, H = Clay, LL > 50%				

Figure 1-6. Unified Soil Classification System

References

Schoeneberger, P.J., D.A. Wysocki, E.C. Benham, and Soil Survey Staff. 2012. Field book for describing and sampling soils, Version 3.0 Natural Resources Conservation Service, National Soil Survey Center, Lincoln, NE.

Soil Science Division Staff. 2017. Soil Survey Manual. C. Ditzler, K. Scheffe, and H.C. Monger (eds.). USDA Handbook 18. Government Printing Office, Washington, D.C.

Soil Survey Staff. 2014. Keys to Soil Taxonomy, 12th ed. USDA-Natural Resources Conservation Service, Washington, D.C.

Soil Survey Staff, Natural Resources Conservation Service, United States Department of Agriculture. Web Soil Survey. Available online at <http://websoilsurvey.nrcs.usda.gov/> . Accessed 05/20/2022.

U.S. Department of Agriculture, Natural Resources Conservation Service. National Soil Survey Handbook, Title 430-VI. http://www.nrcs.usda.gov/wps/portal/nrcs/detail/soils/ref/?cid=nrcs142p2_054242. Accessed 5/30/2022.

Instructions for Use of Web Soil Survey (WSS) for Generating Engineering, Physical & Chemical Properties of Soils

To access the Web Soil Survey Home page, click the following link:

<https://websoilsurvey.sc.egov.usda.gov/App/HomePage.htm>

The Web Soil Survey page should be displayed.

You are here: Web Soil Survey Home

The simple yet powerful way to access and use soil data.

START WSS

Welcome to Web Soil Survey (WSS)

Web Soil Survey (WSS) provides soil data and information produced by the National Cooperative Soil Survey. It is operated by the USDA Natural Resources Conservation Service (NRCS) and provides access to the largest natural resource information system in the world. NRCS has soil maps and data available online for more than 95 percent of the nation's counties and anticipates having 100 percent in the near future. The site is updated and maintained online as the single authoritative source of soil survey information.

Soil surveys can be used for general farm, local, and wider area planning. Onsite investigation is needed in some cases, such as soil quality assessments and certain conservation and engineering applications. For more detailed information, contact your local USDA Service Center at the following link: [USDA Service Center](#) or your NRCS State Soil Scientist at the following link: [NRCS State Soil Scientist](#).

- Know Web Soil Survey (WSS)
- Know Web Soil Survey Requirements
- Know Web Soil Survey operation hours
- Find what areas of the U.S. have soil data
- Find information by topic
- Know how to hyperlink from other documents to Web Soil Survey
- Know the SSURGO data structure
- Use Web Soil Survey on a mobile device

Announcements/Events

- Web Soil Survey 3.4.0 has been released! [View Web Soil Survey](#)

Click the Start Web Soil Survey (WSS) button.

engineering applications. For more detailed information, contact your local USDA Service Center at the following link: [USDA Service Center](#) or your NRCS State Soil Scientist at the following link: [NRCS State Soil Scientist](#).

Four Basic Steps

1. Define...
 - Area of Interest (AOI)** Use the **Area of Interest** tab to define your area of interest.
 - Click or Press the Enter or Spacebar key to view the larger image. Press the Escape key to close.
2. View...
 - Soil Map** Click the **Soil Map** tab to view or print a soil map, and detailed descriptions of the soils in your Area of Interest.
 - Click or Press the Enter or Spacebar key to view the larger image. Press the Escape key to close.

Announcements/Events

- Web Soil Survey 3.4.0 has been released! [View Web Soil Survey release history](#)
- Sign up for e-mail updates via GovDelivery

I Want Help With...

- Getting Started With Web Soil Survey
- How to use Web Soil Survey
- How to use Web Soil Survey Online Help
- Known Problems and Workarounds
- Frequently Asked Questions
- Citing Web Soil Survey as a source of soils data

Note the "I Want Help With..." on the WSS page. This has some very useful information for the beginning user of WSS.

After clicking the Start WSS button, the Area of Interest (AOI) page should be displayed that shows the entire Continental U.S. There are numerous ways to find your AOI. Here is one method using the State and County.

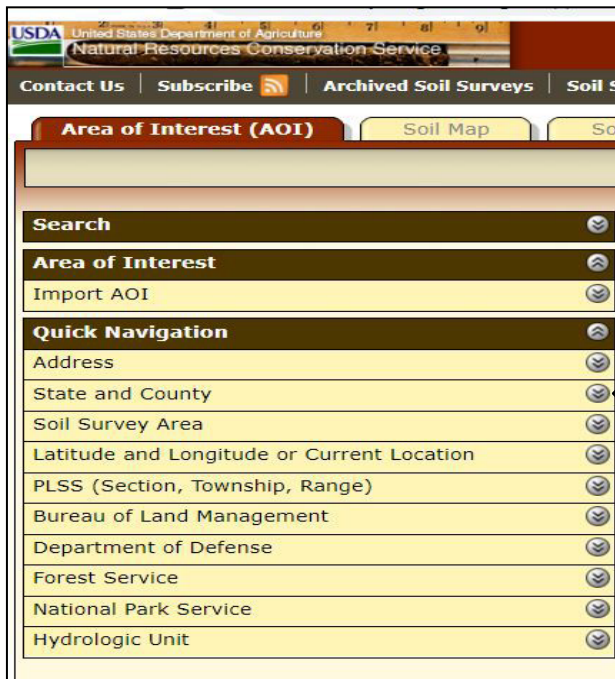

Under the “Quick Navigation“ area, click the drop-down button right of the “State and County” method.

The State and County method of navigation will be expanded.

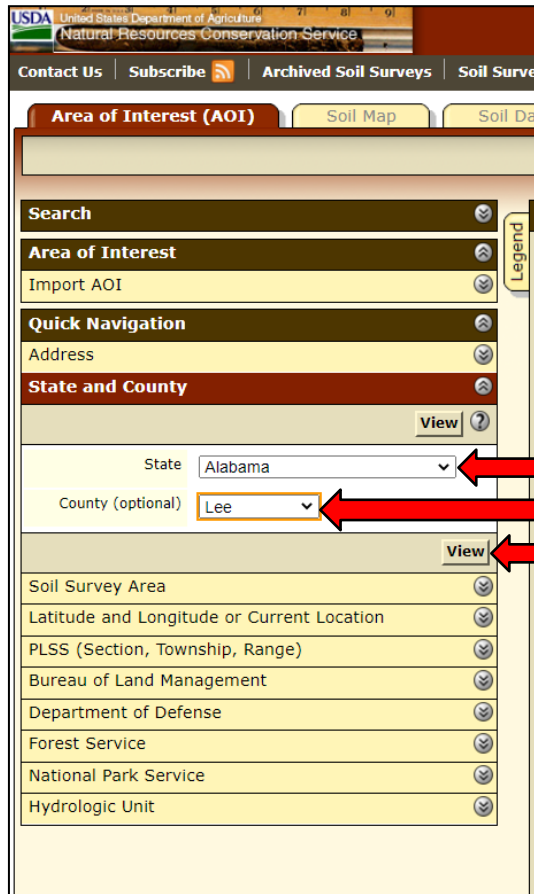

Select the State and County from the drop-down lists, and then click the “View” button.

In this example, Lee County, Alabama should be displayed in the Area of Interest Interactive Map.

At this point you can start to zoom into your AOI by using the “Zoom In” button (+ magnifying glass).

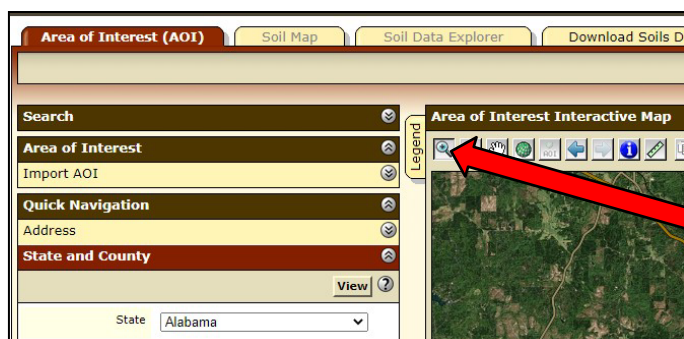

Click the “Zoom In” button. Once selected, click and drag to draw a box around your AOI. Be sure to include a buffer area larger than your AOI.

You can continue to use the Click and Drag method with the “Zoom In” button until you are comfortable with the image in the Area of Interest Interactive Map. If you zoom in too far, use the “Zoom Out” button (- magnifying glass).

You can also use the “Hand” icon to pan the map to your location by clicking and holding the left click button of the mouse and panning the image to your location, release the left click button once you are over the AOI and to stop panning.

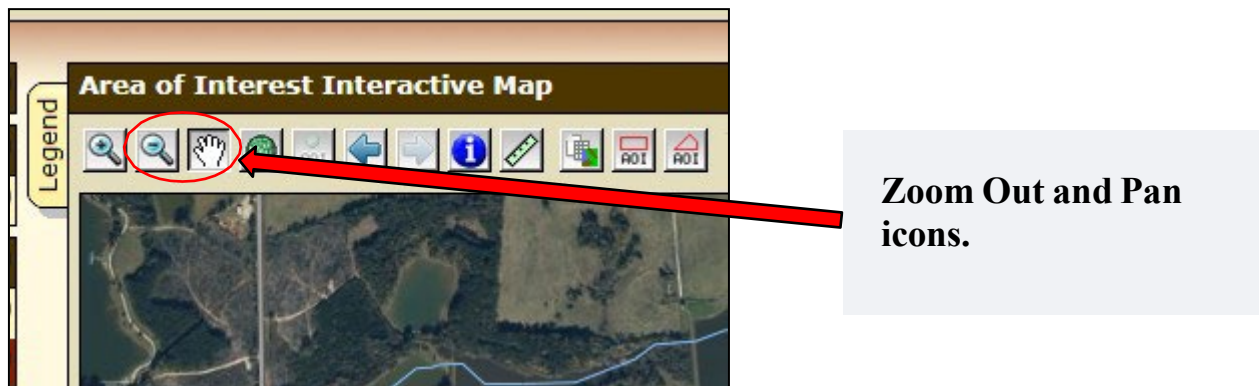

Another tool that makes the map easier to use for some professionals is to add a transparent USGS topographic map over the Area of Interest Interactive Map where you can see the satellite image and the USGS contours at the same time. To do this, click the “Legend” tab on the top left of the map, grab the scrolling bar at the right of the Layer Properties Menu, scroll down to “Background” and check the box next to the “Topographic Map”.

Hold your cursor over the term “Topographic Map” on the menu, right click your mouse, and then click “Edit Layer Properties”. An “Edit Map Layer Properties” will be displayed. Grab the Opacity sliding scale with your mouse and move it to the left to about 40%. Click the “Apply” button. If the image is OK, simply click the “OK” button. If not, adjust the opacity scale to what you want and then click “Apply” and “OK”.

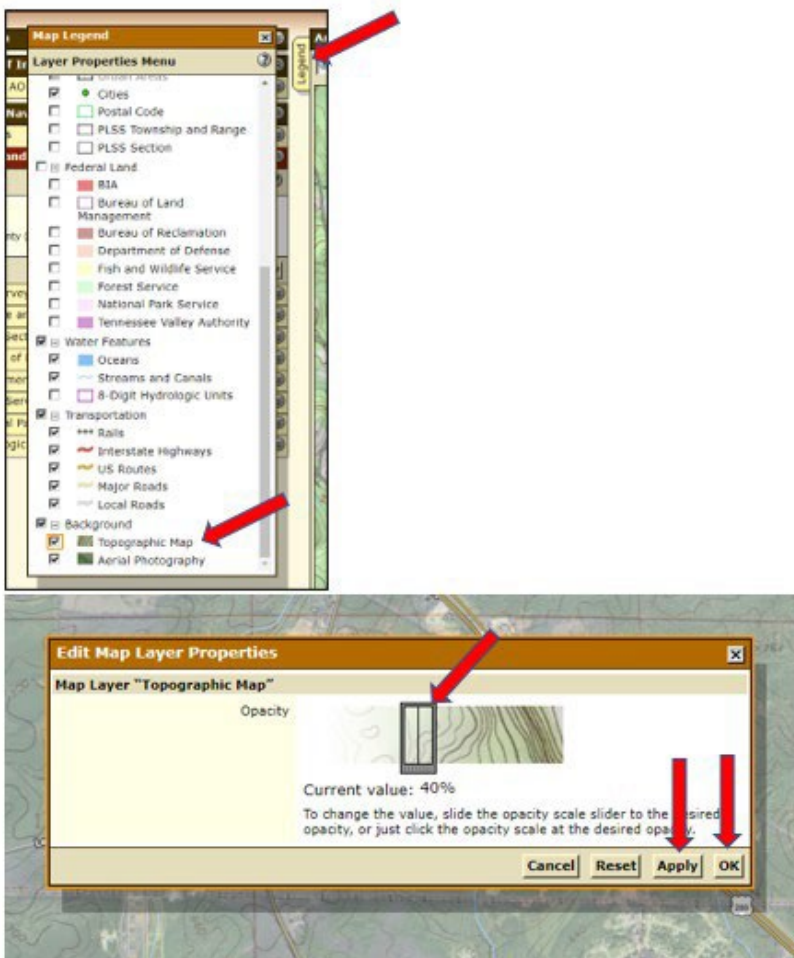

Now you are ready to identify the area of your project in which you need soil data. If your area is square or rectangular, use the “Define AOI by Rectangle” button (a red rectangle with AOI), then using the click and drag method, outline your AOI on the map.

If your area is better defined with a polygon use the “Define AOI by Polygon” button (a red polygon with AOI) by clicking around your area and then double clicking when you are done. (Note: With the topographic background visible, you can use the polygon AOI feature to define a watershed boundary.)

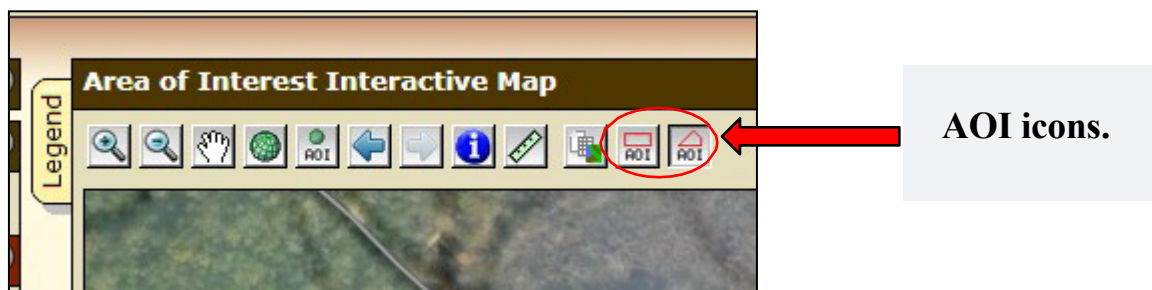

After you have defined your AOI, the Area of Interest Interactive Map should show your area cross-hatched.

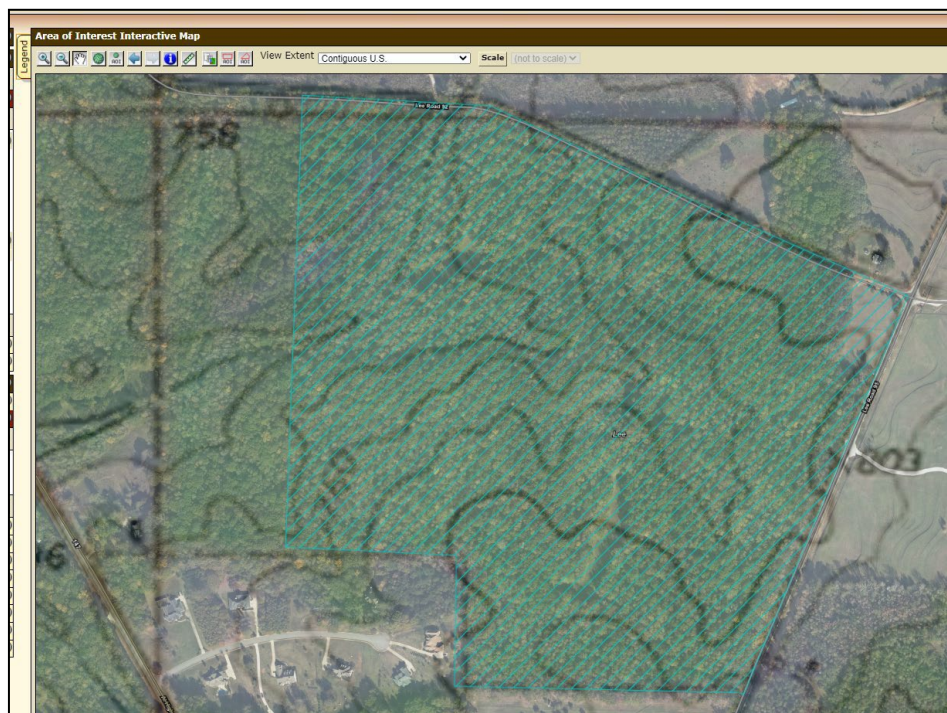

To generate your Soil Map for your AOI click the “Soil Map” tab just right of the AOI tab.

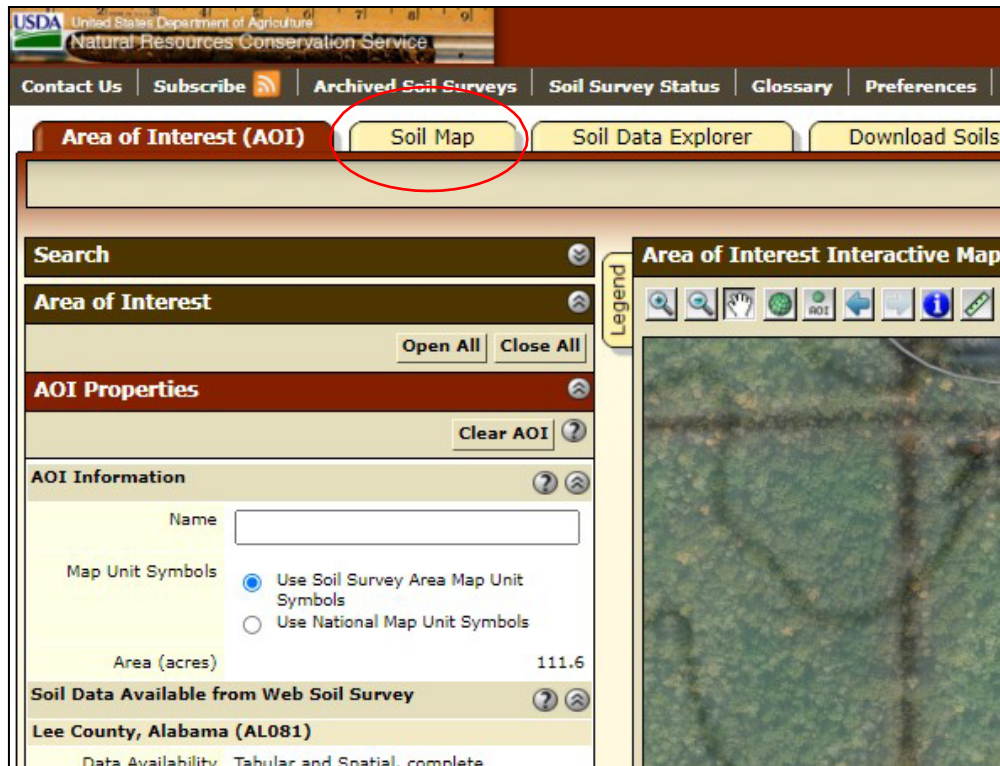

Your Soil Map will be generated along with a Map Unit Legend for the soils in your AOI that gives the Map Unit Names, acreage information, and percent of AOI.

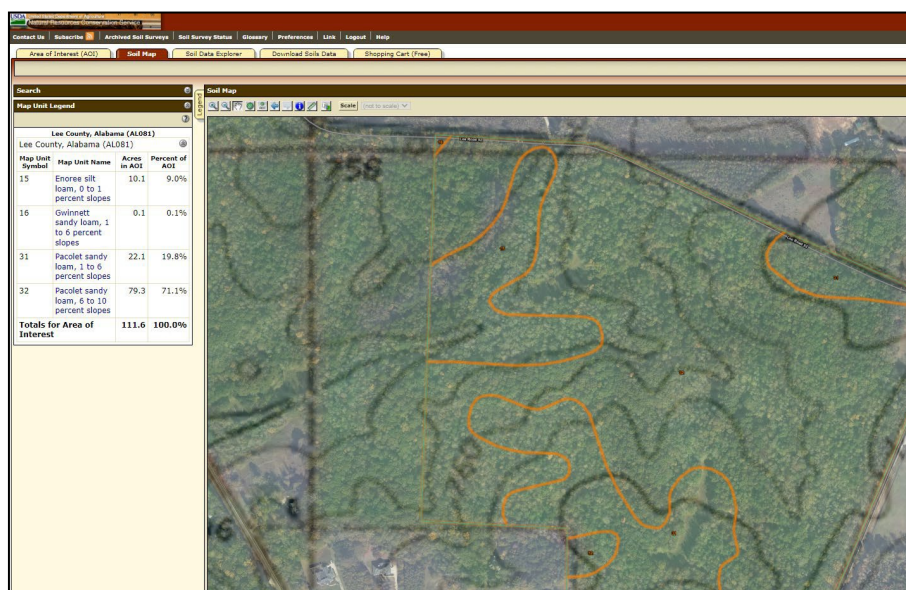

To get to the Engineering Properties for the Soils within your Area of Interest, click the “Soil Data Explorer” tab, then click the “Soil Reports” tab on the new tabs that are displayed, click the drop-down icon to the right of “Soil Physical Properties”, and finally click the drop-down icon to the right of the “Engineering Properties”.

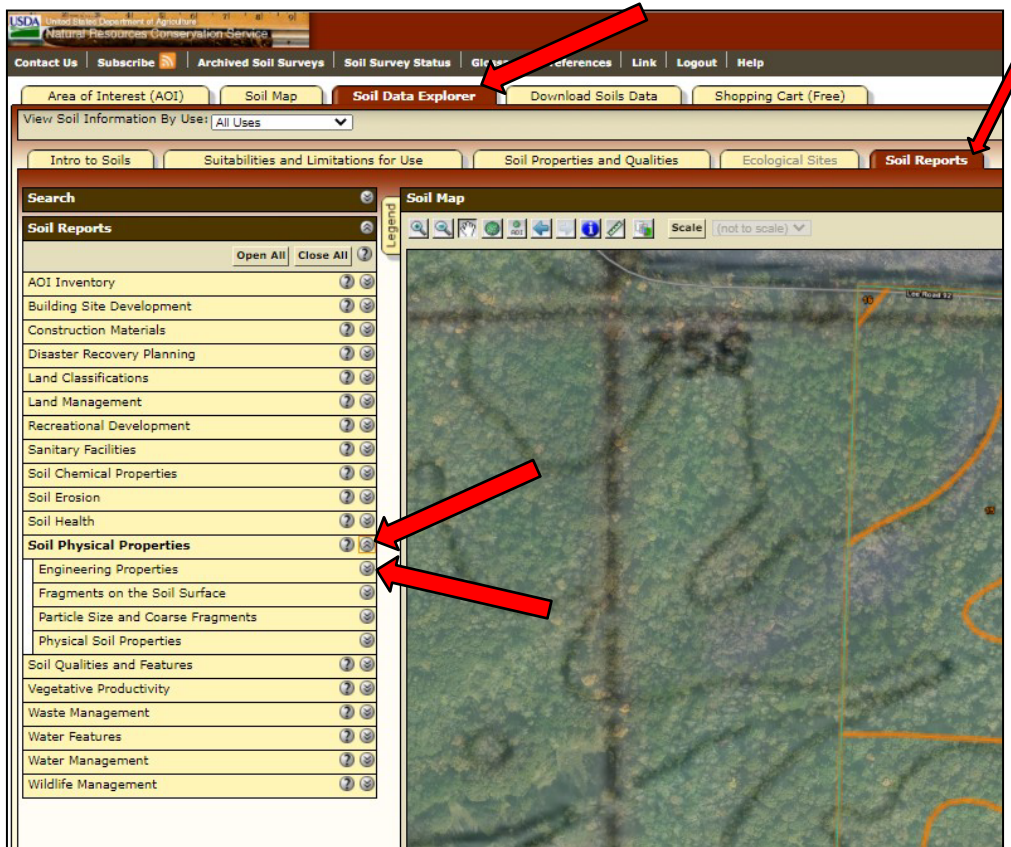

In the new Engineering Properties window click “View Soil Report”.

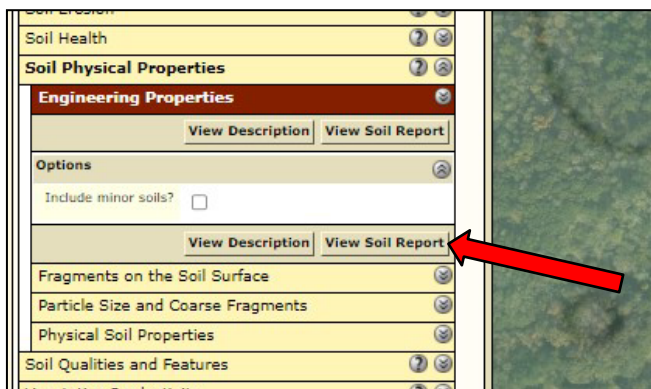

An Engineering Properties report along with the Descriptions for the properties should now be available below your AOI Soil Map.

Report — Engineering Properties														
Absence of an entry indicates that the data were not estimated. The asterisk "*" denotes the representative texture; other possible textures follow the dash. The criteria for determining the hydrologic soil group for individual soil components is found in the National Engineering Handbook, Chapter 7 issued May 2007 (http://directives.sc.gov.usda.gov/OpenNonWebContent.aspx?content=17757.vrba). Three values are provided to identify the expected Low (L), Representative Value (R), and High (H).														
Lee County, Alabama														
Map unit symbol and soil name	Pct. of map unit	Hydrologic group	Depth In	USDA texture	Classification		Pct Fragments		Percentage passing sieve number—				Liquid limit L-R-H	Plasticity Index L-R-H
					Unified	AASHTO	>10 inches L-R-H	3-10 inches L-R-H	4 L-R-H	10 L-R-H	40 L-R-H	200 L-R-H		
15—Eneore silt loam, 0 to 1 percent slopes														
Eneore	85	B/D	0-9	Silt loam	CL, CL-ML, ML	A-4, A-6, A-7	0-0-0	0-0-0	98-99-100	95-98-100	90-95-100	60-73-85	20-35-50	4-12-20
			9-42	Sandy loam, loam, silt loam	CL-ML, ML, SC-SM, SM	A-2, A-4	0-0-0	0-0-0	95-98-100	90-95-100	50-73-95	25-43-60	0-20-40	NP-5-10
			42-60	Loam	CL-ML, ML, SC-SM, SM, CL	A-2, A-4	0-0-0	0-0-0	95-98-100	90-95-100	50-70-90	15-35-55	0-20-40	NP-5-10
16—Gwinnett sandy loam, 1 to 6 percent slopes														
Gwinnett	80	B	0-8	Sandy loam	ML, SC, SC-SM, SM	A-2, A-4, A-6, A-2-4	0-0-0	0-2-3	95-98-100	85-93-100	65-78-90	30-40-50	0-16-32	NP-8-15
			8-39	Clay, sandy clay, clay loam	CH, CL, MH, ML	A-6, A-7	0-0-0	0-2-4	95-98-100	90-95-100	75-85-95	51-66-80	38-52-65	16-23-30
			39-50	Weathered bedrock	—	—	0-0-0	0-0-2	95-97-100	90-95-100	75-85-95	51-65-80	0-0-0	NP
31—Pacolet sandy loam, 1 to 6 percent slopes														
Pacolet	80	B	0-6	Sandy loam	SC-SM, SM	A-2, A-2-4	0-0-0	0-1-2	85-93-100	80-90-100	60-70-80	20-28-35	0-18-36	NP-5-10
			6-23	Sandy clay, clay loam, clay	CH	A-7	0-0-0	0-0-1	80-90-100	80-90-100	60-78-95	51-63-75	49-51-53	28-30-32
			23-40	Sandy loam, fine sandy loam, loam	SC-SM, SM	A-2-4, A-4	0-0-0	0-1-2	80-90-100	70-85-100	60-75-90	25-38-50	0-14-28	NP-3-6
32—Pacolet sandy loam, 6 to 10 percent slopes														
Pacolet	75	B	0-3	Sandy loam	SC-SM, SM	A-2, A-2-4	0-1-1	0-1-2	85-93-100	80-90-100	60-70-80	20-28-35	0-18-36	NP-5-10
			3-34	Sandy clay, clay loam, clay	CH	A-6, A-7	0-1-1	0-1-1	80-90-100	80-90-100	60-78-95	51-63-75	28-51-55	28-30-33
			34-60	Sandy clay, clay loam, clay	CH	A-7	0-1-1	0-1-1	80-90-100	80-90-100	60-78-95	51-63-75	50-52-54	28-30-32

Description — Engineering Properties

Engineering Properties
 This table gives the engineering classifications and the range of engineering properties for the layers of each soil in the survey area.
 Hydrologic soil group is a group of soils having similar runoff potential under similar storm and cover conditions. The criteria for determining hydrologic soil group is found in the National Engineering Handbook, Chapter 7 issued May 2007 (<http://directives.sc.gov.usda.gov/OpenNonWebContent.aspx?content=17757.vrba>). Listing HSGs by soil map unit component and not by soil series is a new concept for the engineers. Past engineering references contained lists of HSGs by soil series. Soil series are continually being defined and redefined, and the list of soil series names changes so frequently as to make the task of maintaining a single national list virtually impossible. Therefore, the criteria is now used to calculate the HSG using the component soil properties and no such national series lists will be maintained. All such references are obsolete and their use should be discontinued. Soil properties that influence runoff potential are those that influence the minimum rate of infiltration for a bare soil after prolonged wetting and when not frozen. These properties are depth to a seasonal high water table, saturated hydraulic conductivity after prolonged wetting, and depth to a layer with a very slow water transmission rate. Changes in soil properties caused by land management or climate changes also cause the hydrologic soil group to change. The influence of ground cover is treated independently. There are four hydrologic soil groups: A, B, C, and D, and three dual groups: A/D, B/D, and C/D. In the dual groups, the first letter is for drained areas and the second letter is for undrained areas.
 The four hydrologic soil groups are described in the following paragraphs:
 Group A: Soils having a high infiltration rate (low runoff potential) when thoroughly wet. These consist mainly of deep, well drained to excessively drained sands or gravelly sands. These soils have a high rate of water transmission.

To create a Printable Version of the Engineering Properties of your AOI, scroll back up to the top of the page and click the “Printable Version” button. The Engineering Report will open as an Adobe document that can be printed or saved.

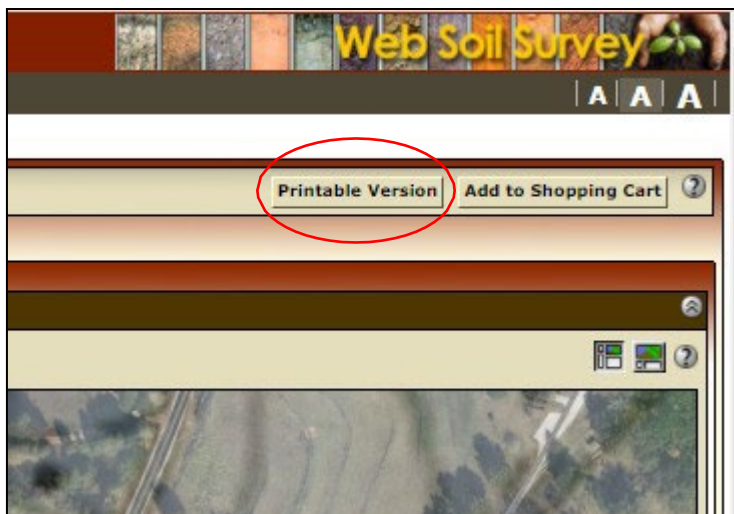

If you desire to also have the erodibility factors for the soils in your AOI, go to the Soil Reports menu and select “Physical Soil Properties” drop-down and then “View Soil Report”. Use the same process for printing or saving the information.

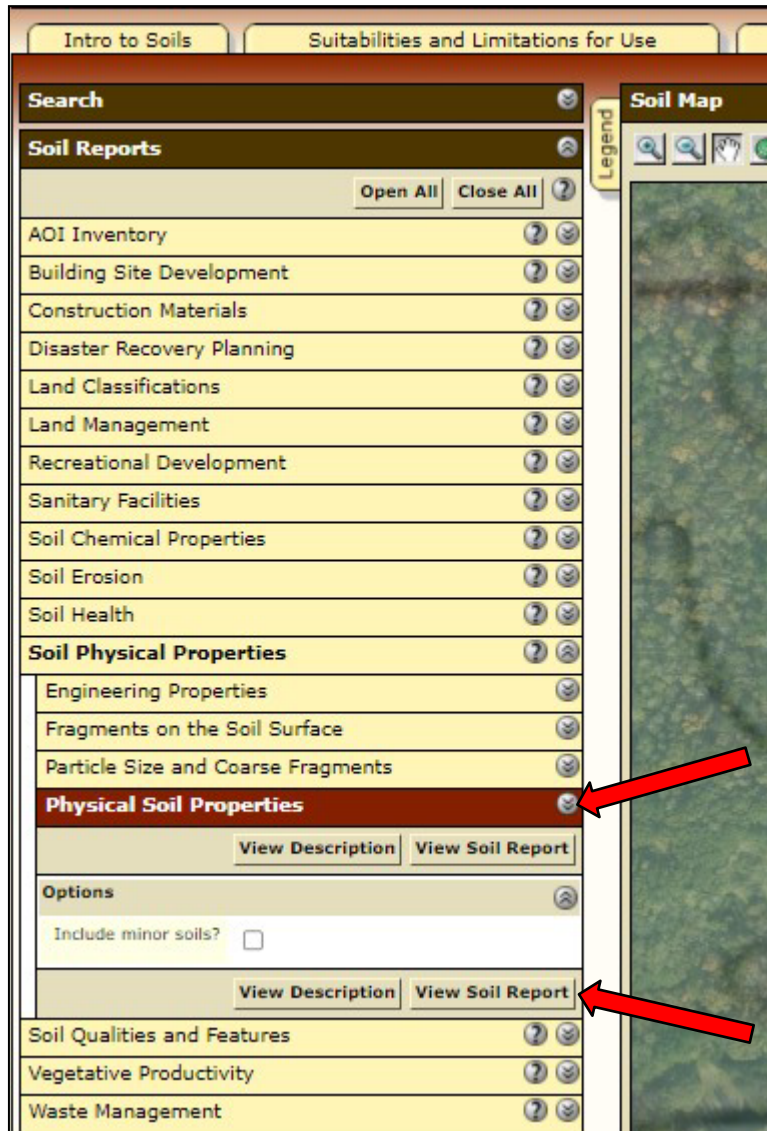

If you desire to have the pH of the soils in your AOI, go to the Soil Reports menu and select “Soil Chemical Properties” drop-down and then “View Soil Report”. Use the same process for printing or saving the information.

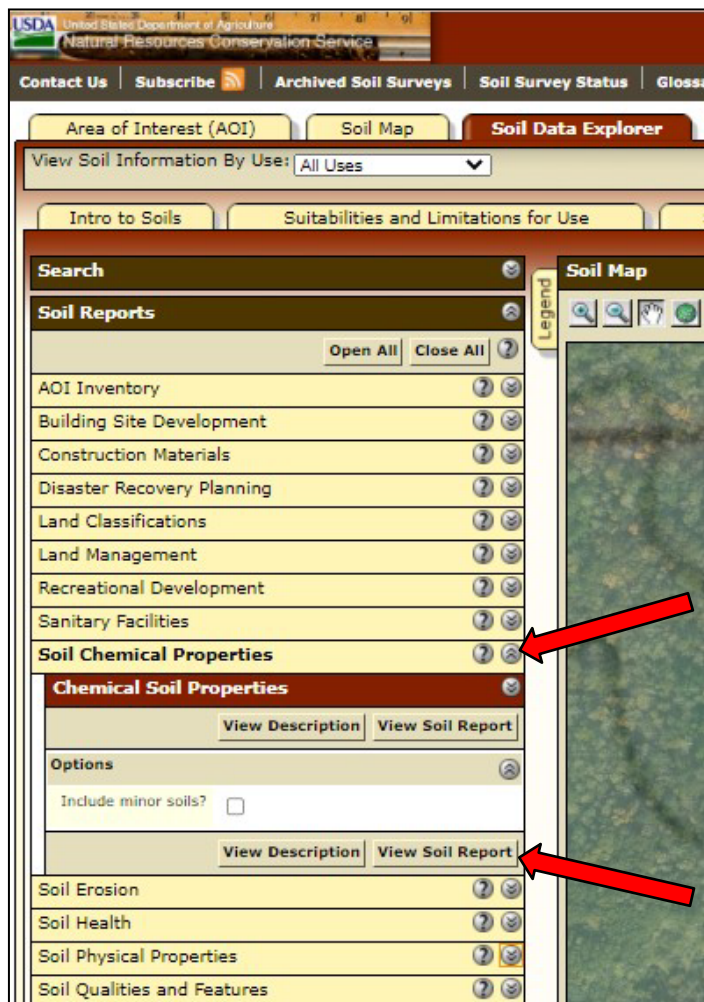

Hopefully this exercise helps you to understand how the WSS functions. There are volumes of data available through this web-based tool. Here is a link to the WSS informational brochure:

<https://nrcspad.sc.egov.usda.gov/DistributionCenter/pdf.aspx?productID=865>

Also, remember that a Soil Survey is a tool to provide “general” soils information. A site-specific soil survey completed by a professional soil scientist may be necessary to fully understand the soils in your AOI.

Standard Specification for
**Geosynthetic Specification
for Highway Applications**
AASHTO Designation: M 288-17

**Technical Section: 4e, Joints, Bearings,
and Geosynthetics**
Release: Group 2 (June 2017)

1. SCOPE

- 1.1. This is a materials specification covering geosynthetics for use in subsurface drainage, separation, stabilization, erosion control, temporary silt fence, paving, and soil (walls and slopes). This is a material purchasing specification and design review of use is recommended.
- 1.2. This specification sets forth a set of physical, mechanical, and endurance properties that must be met or exceeded by the geosynthetic being manufactured.
- 1.3. In the context of quality systems and management, this specification represents a manufacturing quality control (MQC) document. However, its general use is essentially as a recommended design document.
- 1.4. This specification is intended to assure both good quality and performance of geosynthetics used as listed in Section 1.1, but is possibly not adequate for the complete specification in a specific situation, especially in reinforcement applications. Additional tests, more restrictive values for the tests indicated, or values based on project specific design may be necessary under conditions of a particular application.
- 1.5. Minimum strength values provided in this specification are based on geosynthetic survivability from installation stresses. Designers should be aware that the classes and/or property requirements in this specification reflect this basic premise. Refer to Appendix X1 for most geosynthetic construction guidelines.

2. REFERENCED DOCUMENTS

- 2.1. *AASHTO Standards:*
- R 69, Determination of Long-Term Strength for Geosynthetic Reinforcement
 - T 88, Particle Size Analysis of Soils
 - T 90, Determining the Plastic Limit and Plasticity Index of Soils
 - T 99, Moisture-Density Relations of Soils Using a 2.5-kg (5.5-lb) Rammer and a 305-mm (12-in.) Drop
 - T 289, Determining pH of Soil for Use in Corrosion Testing
- 2.2. *ASTM Standards:*¹

 TS-4e

M 288-1

AASHTO

© 2017 by the American Association of State Highway and Transportation Officials.
All rights reserved. Duplication is a violation of applicable law.

The complete version of this standard is available for purchase in digitized form via the AASHTO Bookstore at:

<https://store.transportation.org/>

Glossary

This glossary includes terms pertinent to erosion and sediment control and stormwater management and most of the terms are used in this handbook.

AASHTO classification - The official classification of soil materials and soil aggregate mixtures for highway construction used by the American Association of State Highway and Transportation Officials (AASHTD).

Abutment - The sloping sides of a valley that support the ends of a dam.

Acid soil - A soil with a preponderance of hydrogen ions (and probably of aluminum) in proportion to hydroxyl ions. Specifically, soil with a pH value less than 7.0. For most practical purposes, a soil with a pH value less than 6.6.

Acre-foot - The volume of soil or water that will cover 1 acre to a depth of 1 foot.

Alkaline soil - A soil that has a pH greater than 7.0, particularly above 7.3, throughout most or all of the root, zone. The term is commonly applied to only the surface layer or horizon of a soil.

Alluvial soils - Soils developed from transported and relatively recently deposited material (alluvium) characterized by a weak modification (or none) of the original material by soil-forming processes.

Alluvium - A general term for all detrital material deposited by water and includes gravel, sand, clay and mixtures of these. Unless otherwise noted, alluvium is unconsolidated.

Antecedent moisture conditions - The degree of wetness of a watershed at the beginning of a storm.

Anti-seep collar - A device constructed around a pipe or other conduit placed through a dam, levee, or dike for the purpose of preventing soil movement and piping failures.

Anti-vortex device - A facility placed at the entrance to a pipe conduit structure such as a drop inlet spillway or hood inlet spillway to prevent air from entering the structure when the pipe is flowing full.

Appendix

Apron - A pad of non-erosive material designed to prevent scour holes developing at the outlet ends of culverts, outlet pipes, grade stabilization structures, and other water control devices.

Balled and burlapped plant - A tree or shrub that has been dug up and the soil around the tree roots has been retained by enclosing it with burlap.

Bare-root - Trees or seedlings that have been removed from the soil and have exposed roots.

Barrel - A conduit placed through a dam, levee, or dike to control the release of water.

Base flow - Stream discharge derived from groundwater sources as differentiated from surface runoff. Sometimes considered to include flows from regulated lakes or reservoirs.

Bearing capacity - The maximum load that a material can support before failing.

Bedrock - The more or less solid rock in place either on or beneath the surface of the earth. It may be soft, medium or hard and have a smooth or irregular surface.

Berm - A narrow shelf or flat area that breaks the continuity of a slope.

Borrow area – An area where earth material is removed for use at another location for the construction of embankments or other earth fill structures.

Brownfield - The State of Alabama defines a “brownfield” as any abandoned, idled, or underused industrial and commercial property where expansion or redevelopment can be complicated by real or perceived contamination. Federal law expands this definition to include any real property, the expansion, redevelopment, or reuse of which may be complicated by the presences of a hazardous substance, pollutant, or contaminant. The Alabama Department of Environmental Management Land Division provides oversight of assessment and remediation activities concerning these types of sites through its Brownfield Redevelopment and Voluntary Cleanup Program.

Bunchgrass - A grass plant species that forms a distinct clump and does not spread by horizontal plant parts above or below ground (stolons or rhizomes).

Buoyant weight - The downward force exerted by an object with a specific gravity greater than 1, when it is submerged in water.

Butt joint – a technique in which two fiber rolls are firmly pressed together, end to end, during the field installation process ensuring that there are no gaps between the adjacent rolls to minimize potential for water flow and erosion between the rolls.

Channel stabilization - Protecting the sides and bed of a channel from erosion by controlling flow velocities and flow directions using jetties, drops or other structures and/or by lining the channel with a suitable liner such as vegetation, riprap, concrete or other similar material.

Chute - A high-velocity, open channel for conveying water down a steep slope without erosion, usually paved.

Clay – A clay particle is defined by the USDA as particles of soil materials less than 0.002 mm in diameter. Particle size may vary by soil classification system. A clay soil is defined by the USDA as a soil textural class (category) that contains 40% or more clay particles, less than 45% sand soil particles and less than 40% silt soil particles. Textural classification may vary by soil classification system.

Coir - A term used to refer to products such as rolled erosion control products and wattles manufactured from the fibers of coconuts.

Compaction - In soil engineering, the process by which the soil grains are rearranged to decrease void space and bring them into closer contact with one another, thereby increasing the weight of solid material per cubic foot. In soil quality, a dense layer of soil, created by traffic, that impedes root penetration and moisture movement through the soil.

Conservation district - A special-purpose entity created under state enabling law to develop and carry out a program of soil, water, and related resource conservation, use, and development within its boundaries, usually a subdivision of state government with a local governing body but with limited authorities. Other names include soil conservation district, soil and water conservation district and natural resources district.

Construction phasing - segmenting development of a large construction site to reduce the area of disturbance at a given time.

Construction sequencing - a construction schedule used to avoid conflicts and/or ensure desired performance of BMPs.

Containerized plant - A plant that is grown in a container for the purpose of being transplanted.

Contour - An imaginary line on the surface of the earth connecting points of the same elevation.

Critical area - A severely eroded sediment producing area that requires special management to establish and maintain vegetation in order to stabilize soil conditions.

Cut - Portion of land surface or area from which earth has been removed or will be removed by excavating the depth below the original ground surface to the excavated surface.

Cut-and-fill - Process of earth grading by excavating part of a higher area and using the excavated material for fill to raise the surface of an adjacent lower area.

Appendix

Cutoff trench - A long, narrow excavation (keyway) constructed along the center line of a dam, dike, levee or embankment and filled with relatively impervious material intended to reduce seepage of water through porous strata.

Dam - A barrier to confine or impound water for storage or diversion, to prevent gully erosion, or for retention of soil, sediment, or other debris.

Design highwater - The elevation of the water surface at peak flow conditions of the design flood.

Design life - The period of time for which a facility is expected to perform its intended function.

Design storm - A selected rainfall pattern of specified amount, intensity, duration, and frequency that is used as a basis for design.

Dewatering - The removal of water temporarily impounded in a holding basin.

Dibble bar - A tool used for planting trees consisting of either a flat or pointed blade and a bar with a handle for pushing the blade into the soil.

Dike - An embankment to confine or control water, often built along the banks of a river to prevent overflow of lowlands; a levee.

Discharge - Usually the rate, of water flow; a volume of a fluid passing a point per unit time commonly expressed as cubic feet per second, cubic meters per second, gallons per minute, or millions of gallons per day.

Diversion - A channel with a supporting ridge on the lower side constructed at the top, across, or at the bottom of a slope for the purpose of controlling surface runoff.

Diversion dike - A barrier built to divert surface runoff.

Divide, drainage - The boundary between watersheds.

Drainageway - A natural or artificial depression that carries surface water to a larger watercourse or outlet such as a river, lake, or bay.

Drawdown - Lowering of the water surface in an open channel or lake or groundwater.

Drop inlet - Overall structure in which the water drops through a vertical riser connected to a discharge conduit or storm sewer.

Drop spillway - Overall structure in which the water drops over a vertical wall onto an apron at a lower elevation.

Drop structure - A structure for dropping water to a lower level and dissipating its surplus energy without erosion.

Earth dam - A dam constructed of compacted suitable soil materials.

Embankment - A man-made deposit of soil, rock, or other material often used to form an impoundment.

Emergency Spillway (Auxiliary Spillway)- Usually a vegetated earth channel used to safely convey flood discharges around an impoundment structure.

Energy Dissipator - A device used to reduce the energy of flowing water to prevent erosion.

Environment - The sum total of all the external conditions that may act upon a living organism or community to influence its development or existence.

Erodibility - Susceptibility to erosion.

Erosion - The process of detachment and transport of soil particles by water, wind, gravity, ice, or other natural forces. The following terms are used to describe different types of water erosion:

Accelerated erosion - erosion as a result of the activities of man.

Channel erosion - the erosion process whereby the volume and velocity of flow wears away the bed and/or banks of a well-defined channel.

Geologic erosion - the normal or natural erosion caused by geological processes acting over long geologic periods and resulting in the wearing away of mountains, the building up of floodplains, coastal plains, etc.

Gully erosion - a channel deeper than a rill formed by the action of concentrated flow exceeding the allowable shear stress of the soil.

Rill erosion - an erosion process in which numerous small channels only several inches deep are formed; occurs mainly on recently disturbed and exposed soils.

Splash erosion - the spattering of small soil particles caused by the impact of raindrops on bare soils.

Sheet erosion - the removal of a fairly uniform thin layer of soil from the surface layer by runoff water.

Interrill erosion – the combination of splash and sheet erosion.

Appendix

Evapotranspiration - The combined loss of water from an area by evaporation from the soil surface and by transpiration of plants.

Excess rainfall - The amount of rainfall that runs directly off an area.

Fertilizer - Any organic or inorganic material of natural or synthetic origin that is added to a soil to supply elements essential to plant growth.

Fertilizer analysis - The percentage composition of fertilizer, expressed in terms of nitrogen, phosphoric acid, and potash. For example, a fertilizer with a 6-12-6 analysis contains 6 percent nitrogen (N), 12 percent available phosphoric acid (P_2O_5) and 6 percent water-soluble potash (K_2O).

Filter diaphragm – A designed zone of filter material (usually well-graded, clean sand) constructed around a conduit to prevent problems associated with seepage or internal erosion in earthfill surrounding a conduit. Must include a filter compatible outlet.

Filter fabric - A woven or non-woven, water-permeable material generally made of synthetic products such as polypropylene and used in erosion and sediment control applications to trap sediment or prevent the movement of fine soil particles.

Flood peak - The highest stage or greatest discharge attained by a flood event. Thus, peak stage or peak discharge.

Floodplain - The lowland that borders a stream and is subject to flooding when the stream overflows its banks.

Flood stage - The stage at which overflow of the natural banks of a stream begins.

Floodway - A channel, either natural, excavated, or bounded by dikes and levees, used to carry flood flows.

Flume - A constructed channel lined with erosion-resistant materials used to convey water on steep grades without erosion.

Forebay - an impoundment upstream of detention-based practices intended to slow flow velocity, facilitate sedimentation, and capture larger soil particles.

Freeboard - A vertical distance between the elevation of the design high-water and the top of a dam, diversion ridge, or other water control device.

Frequency of storm (design storm frequency) - The anticipated period in years that will elapse before another storm of equal intensity and/or total volume will recur: a 10-year storm can be expected to occur on the average once every 10 years.

Froude no. (F) - A calculated number for classifying water flow as critical ($F=1$), supercritical ($F>1$) or subcritical ($F<1$).

Gabion - semi-flexible and permeable wire baskets typically filled with cobble or boulder-sized rock commonly used for erosion control of slopes and channels.

Gauge - A device for measuring precipitation, water level, discharge, velocity, pressure, temperature, etc., e.g., a rain gauge. A measure of the thickness of metal, e.g., diameter of wire or wall thickness of steel pipe.

Geotextile - permeable fabrics which, when used in association with soil, have the ability to separate, filter, reinforce, protect, or drain.

Gradation - The distribution of the various sized particles that constitute a sediment, soil, or other material such as riprap.

Grade - (1) The slope of a road, a channel, or natural ground. (2) The finished surface of a canal bed, roadbed, top of embankment, or bottom of excavation; any surface prepared to a design elevation for the support of construction such as paving or the laying a conduit. (3) To finish the surface of a canal bed, roadbed, top of embankment, or bottom of excavation, or other land area to a smooth, even condition.

Grade stabilization structure - A structure for the purpose of stabilizing the grade of a gully or other watercourse, thereby preventing further head-cutting or lowering of the channel bottom (Drop Structure).

Gradient - Change of elevation, velocity, pressure, or other characteristics per unit length; slope.

Grading - The cutting and/or filling of the land surface to a desired slope or elevation.

Grass - A member of the botanical family Gramineae, characterized by blade-like leaves that originate as a sheath wrapped around the stem.

Grass or legume, annual - A plant which germinates, grows, reproduces, and dies in one growing season or 1 year's time.

Grass or legume, cool-season - A grass or legume which is usually planted in the fall or occasionally late winter and it makes most of its growth during the cool season of the year, (fall, late winter and spring). Flowering and seed production occur in late spring. Cool-season species are usually dormant or make little growth during the hot summer months.

Grass or legume, perennial - A plant which under suitable conditions has the ability to live for more than 1 year. A perennial may become dormant at certain times of the year, but will resume growth at the end of its dormant period.

Grass or legume, warm-season - A grass or legume which is usually planted in the spring and makes its growth during the warm season (late spring and summer months). Flowering and seed production usually occur in late summer or early fall. Warm-season species become dormant in late fall and resume growth in the early spring.

Grassed waterway - A natural or constructed waterway, usually broad and shallow, covered with erosion-resistant grasses and used to safely conduct surface water from an area. Usually referred to as a Grass Swale on construction sites.

Groundcover - Low-growing herbaceous plants that spread vegetatively to produce a dense, continuous cover over a landscape.

Ground water - That water that moves through the plant root zone and under the influence of gravity continues moving downward until it enters the ground water reservoir.

Head - The height of water above any plain of reference. The energy, either kinetic or potential, possessed by each unit weight of a liquid, expressed as the vertical height through which a unit weight would have to fall to release the average energy possessed. Used in various compound terms such as pressure head or velocity head.

Head loss - Energy loss due to friction, eddies, changes in velocity, elevation or direction of flow.

Headwater - The source of a stream. The water upstream from a structure or point on a stream.

Hydraulic erosion control product (HECP) – a water-based mixture of materials that may include: mulch, seed, fertilizer, soil amendments, tackifiers, and polymers that are applied to provide soil stabilization.

Hydrograph - A graph showing for a given point on a stream - the discharge, stage (depth), velocity, or other property of water with respect to time.

Hydrologic cycle - The circuit of water movement from the atmosphere to the earth and back to the atmosphere through various stages or processes such as precipitation, interception, runoff, infiltration, percolation, storage, evaporation, and transpiration.

Hydrologic soil group - Categories that reflect runoff and are good indicators of infiltration and how rapidly water moves through the soil.

<u>Group</u>	<u>Soil Description</u>
A	Deep, well drained sands and gravels with low runoff potential and high infiltration rates.

- B Soils that are moderately deep to deep, moderately drained, moderately fine to moderately coarse texture with moderate runoff potential and moderate infiltration rates.
- C Soils with an impeding layer, or moderately fine to fine texture with high runoff potential and low infiltration rates.
- D Clay, or soils with high water table, or shallow over an impervious layer such as stone with very high runoff potential and very low infiltration rates.

Hydrology - The science of the behavior of water in the atmosphere, on the surface of the earth, and underground.

Impact basin - A device used to dissipate the energy of flowing water to reduce erosion. Generally constructed of concrete partially submerged with baffles to dissipate velocities.

Impervious - Not allowing infiltration.

Impoundment - Generally, an artificial water storage area, as a reservoir, pit, dugout, sump, etc.

Infiltration - The gradual downward flow of water from the surface through soil to ground water and water table reservoirs.

Invert - The inside bottom of a culvert or other conduit.

Keyway - A cutoff trench dug beneath the entire length of a dam to cut through soil layers that may cause seepage and possible dam failure.

Laminar flow - Flow at relatively slow velocity in which fluid particles slide smoothly along straight lines everywhere parallel to the axis of a channel or pipe.

Legume - Any member of the pea or pulse family which includes peas, beans, peanuts, clovers, alfalfas, sweet clovers, lespedezas, vetches, black locust, and kudzu. Practically all legumes are nitrogen-fixing plants.

Level Spreader - a structure or berm designed to slow and evenly spread concentrated runoff and release it uniformly as sheet flow across its entire width onto a stabilized area.

Liquid limit - The moisture content at which the soil passes from a plastic to a liquid state.

Mean depth - Average depth; cross-sectional area of a stream or channel divided by its surface or top width.

Appendix

Mean velocity - The average velocity of a stream flowing in a channel conduit at a given cross-section or in a given reach. It is equal to the discharge divided by the cross-sectional area of the reach.

Mulch - A natural or artificial layer of plant residue or other materials covering the land surface which conserves moisture, holds soil in place, aids in establishing plant cover, and minimizes temperature fluctuations.

Natural drainage - The flow patterns of stormwater runoff over the land in its pre-development state.

Nonpoint source pollution - Pollution that enters a water body from diffuse origins on the watershed and does not result from discernible, confined, or discrete conveyances.

Normal depth - The depth of flow in an open conduit during uniform flow for the given conditions.

Open drain - A natural watercourse or constructed open channel that conveys drainage water.

Outfall – a location where water discharges offsite from a pipe, stream, drain, or other conveyance.

Outlet - The point of water disposal from a stream, river, lake, tidewater, or artificial drain.

Outlet channel - A waterway constructed or altered primarily to carry water from man-made structures, such as smaller channels, tile lines, and diversions.

Peak discharge - The maximum instantaneous flow from a given storm condition at a specific location.

Percolation - The movement of water through soil.

Percolation rate - The rate, usually expressed as inches/hour or inches/day, at which water moves through the soil profile.

Perennial stream - A stream that maintains water in its channel throughout the year.

Pervious - Allowing movement of water.

Pesticides - Chemical compounds used for the control of undesirable plants, animals, or insects. The term includes insecticides, herbicides, algacides, rodenticides, nematocides, fungicides, and growth regulators.

pH - A numerical measure of hydrogen ion activity. The neutral point is pH 7.0. All pH values below 7.0 are acid and all above 7.0 are alkaline.

Physiographic region (Province) - Large-scale unit of land defined by its climate, geology, and geomorphic history and, therefore, relatively uniform in physiographic features.

Plastic index - The numerical difference between the liquid limit and the plastic limit of soil; the range of moisture content within which the soil remains plastic.

Plastic limit - The moisture content at which a soil changes from a semi-solid to a plastic state.

Plunge pool - A basin used to dissipate the energy of flowing water usually constructed to a design depth and shape. The pool may be protected from erosion by various lining materials.

Point source - Any discernible, confined and discrete conveyance, including but not limited to any pipe, ditch, channel, tunnel, conduit, well, discrete fissure, container, vessel or other floating craft, from which pollutants are or may be discharged. (Public Law 92-500, Section 5014).

Pollutant - Pollutant includes but is not limited to sediment, dredged spoil, solid waste, incinerator residue, sewage, garbage, sewage sludge, munitions, chemical wastes, biological materials, radioactive materials, heat, wrecked or discarded equipment, rock, sand, cellar dirt and industrial, municipal and agricultural waste discharged into water.

Porosity - The volume of pore space in soil or rock.

Porous Baffle - a pervious barrier installed in a sediment basin perpendicular to the flow path to redistribute energy, reduce turbulence, spread flow across the width, and establish laminar flow, for the purpose of promoting the settling of suspended solids.

Principal spillway - A dam spillway generally constructed of permanent material and designed to regulate the normal water level, provide flood protection and/or reduce the frequency of operation of the emergency spillway.

Qualified design professional - A person adequately trained, experienced and in some instances registered, to plan and/or design erosion and sediment control and stormwater measures applicable to site conditions where assistance is provided. Certified or registered professionals are bound by their ethics commitment to practice in only the areas that they have adequate expertise. Designing certain measures is restricted by state law to specific categories of professionals, i.e. structural measures can only be designed in Alabama by professional engineers registered in Alabama.

Rainfall intensity - The rate at which rain is falling at any given instant, usually expressed in inches per hour.

Rational method - A means of computing storm drainage flow rates, Q , by use of the formula

Appendix

$Q = CIA$, where C is a coefficient describing the physical drainage area, I is the rainfall intensity and A is the area.

Reach - The smallest subdivision of the drainage system consisting of a uniform length of open channel. Also, a discrete portion of river, stream or creek.

Receiving stream - The body of water into which runoff or effluent is discharged.

Retention - The permanent storage of stormwater to prevent it from leaving the development site; Storage for temporary periods is referred to as detention.

Revetment - A constructed face or wall.

Revised Universal Soil Loss Equation 2 – An equation developed by the USDA Agricultural Research Service (USDA-ARS) and partners that predicts sheet and rill erosion rates on sloping landscapes. The equation may be applied to various land uses as a tool for planners to evaluate the effects of various vegetative, structural and management practices.

Rhizome - A plant stem that grows horizontally underground and sends out roots and shoots from the nodes.

Rill - A small channel on a slope caused by soil detachment due to overland flow.

Riparian - Of, on, or pertaining to the banks of a stream, river, or pond.

Riparian rights - A principle of common law which requires that any user of waters adjoining or flowing through his lands must so use and protect them that he will enable his neighbor to utilize the same waters undiminished in quantity and undefiled in quality.

Riser - The inlet portions of a drop inlet spillway that extend vertically from the pipe conduit barrel to the water surface.

Rolled erosion control product (RECP) – a temporary degradable or long-term non-degradable material manufactured or fabricated into rolls designed to reduce soil erosion and assist in the growth, establishment, and protection of vegetation. Sometimes referred to as erosion control blanket or mat.

Runoff - precipitation that is not infiltrated or intercepted within a watershed that flows over a surface, in open channels, and/or in stormwater conveyance systems.

Sand – a sand particle is defined by USDA as materials larger than 0.05 mm (No. 200 sieve) in diameter up to 2.0 mm (No. 10 sieve). A sandy soil is defined by the USDA as a soil textural class that contains 85% or more of sand sized particles.

Saturation - In soils, the point at which a soil or an aquifer will no longer absorb any amount of water without losing an equal amount.

Scarified seed - Seed which has been subjected to abrasive treatment to encourage germination.

Scour - The clearing and digging action of flowing water, especially the downward erosion caused by stream water in sweeping away mud and silt from the stream bed and outside bank of a curved channel.

Sediment - soil particles transported or deposited by the action of wind, water, gravity, or ice, as a product of erosion.

Sediment delivery ratio - The fraction of the soil eroded from upland sources that actually reaches a stream channel or storage reservoir.

Sediment retention barrier – A measure constructed onsite on the contour similarly to a conventional silt fence to protect water quality by reducing turbidity of stormwater. It consists of two high-flow silt fences installed about 18” apart with straw loosely placed between the fences and either straw or a fabric such as jute placed on the ground surface downslope of the fences. An approved flocculant powder is added to the straw and straw/fabric prior to runoff events to remove fines from the runoff. A Buffer Zone must be downstream of the practice.

Sediment retention fiber roll (SRFR) - A manufactured device of a filler material encapsulated within a flexible containment material utilized in sediment and flow control applications such as sediment barriers, inlet protection and small sediment traps. Also, referred to as a sediment log and as a wattle.

Sediment pool - The reservoir space allotted to the accumulation of sediment during the life of the structure.

Sedimentation - termination of settling process resulting in deposition.

Seedbed - The soil prepared by natural or artificial means to promote the germination of seed and the growth of seedlings.

Seedling - A young plant grown from seed, either planted or a volunteer.

Sensitive Waters - A non-regulatory term to describe waters of the state that have been classified, designated, or otherwise identified to have increased significance or recognized uses such as waters classified as suitable for swimming and other whole body water contact sports

(S), public water supply (PWS), etc., waters designated as outstanding national resource waters (ONRW) or outstanding Alabama water (OAW), and water designated as a Tier 1 (impacted

Appendix

water), CWA Section 303(d) listed water, etc. where specialized planning and an increased level of BMP implementation may be warranted.

Shear stress - The coplanar surface stress applied by concentrated flowing stormwater to a swale surface. Swale surfaces have a maximum shear strength that can be withstood without failure of the surface.

Silt - a silt soil is defined by the USDA as a soil textural class (category) that contains 80% or more silt particles (0.05 to 0.002 mm diameter) and less than 12% clay soil particles (less than 0.002 mm diameter).

Slope - Degree of deviation of a surface from the horizontal; measured as a numerical ratio or percent. Expressed as a ration, the first no. is the horizontal distance (run) and the second is the vertical distance (rise), e.g., 2:1. Slope can also be expressed as the rise over the run. For instance, a 2:1 slope is a 50 percent slope.

Sod - Grass and/or legumes held together by its root system and a thin layer of soil.

Soil - The unconsolidated mineral and organic material on the immediate surface of the earth that serves as a natural medium for the growth of land plants.

Soil horizon - A horizontal layer of soil that, through processes of soil formation, has developed characteristics distinct from the layers above and below.

Soil permeability - The attribute of a soil that enables water or air to move through it. Usually expressed in inches/hour or inches/day.

Soil profile - A vertical section of the soil from the surface through all horizons.

Soil Series - the name of horizons (profiles or layers) of soils that are similar and used to distinguish one soil profile from another by characteristics including biological, chemical, and physical properties.

Soil structure - The relation of particles or groups of particles which impart to the whole soil a characteristic manner of breaking; some types are crumb structure, block structure, platy structure, and columnar structure.

Soil texture - The physical structure or character of soil determined by the relative proportions of the soil separates (sand, silt and clay) of which it is composed.

Soil type - term used prior to 1975 to describe a subdivision of a Soil Series that identified both the soil series and features associated with the series such as slope, stoniness, rock or outcrop. Replaced by the USDA with the term Soil Map Unit.

Spillway - A passage such as a paved apron or channel for surplus water over or around or through a dam or similar structure. An open or closed channel, or both, used to convey excess water from a reservoir. It may contain gates, either manually or automatically controlled, to regulate the discharge of excess water.

Sprig - The section of plant stem material (rhizome, shoot, or stolon) used in vegetative planting referred to as sprigging.

Stolon – a plant stem that grows horizontally on the soil surface and produces new plants from its nodes or tips.

Storm frequency - the exceedance probability of a given depth of rainfall over a given duration typically expressed in return interval (years), such as a 10-yr, 24-hr storm event.

Storm sewer - A sewer that carries stormwater, surface drainage, street wash and other wash waters, but excludes sewage and industrial wastes, preferably called a storm drain.

Stormwater pollution prevention plan (SWPPP) – EPA description of a comprehensive site-specific plan of measures committed to address all water (pollutant) discharges and receiving waterbody quality related challenges and issues that are expected to be created by construction on a specific site. The ADEM Construction Best Management Practices Plan (CBMPP) is equivalent to SWPPP.

Streambanks - The usual boundaries, not the flood boundaries, of a stream channel. Right and left banks are named facing downstream.

Subcritical flow - Flow at relatively high velocity where the wave from a disturbance can move upstream. Froude No. less than 1.

Subsoil - The B horizons of soils with distinct profiles. In soils with weak profile development the subsoil can be defined as the soil below which roots do not normally grow.

Subsurface drain - A pervious backfilled trench usually containing stone and perforated pipe for intercepting groundwater or seepage.

Subwatershed - A watershed subdivision of unspecified size that forms a convenient natural unit.

Supercritical flow - Flow at relatively high velocity where - the wave from a disturbance will always be swept downstream. Froude no. is greater than 1.

Surface runoff - Precipitation that falls onto the surfaces of roofs, streets, the ground, etc., and is not absorbed or retained by that surface, but collects and runs off.

Appendix

Swale – A shallow drainageway (natural or constructed).

Tailwater depth - The depth of flow immediately downstream from a discharge structure.

Temporary cover - Temporary vegetative cover of rapid growing annual grasses, small grains, or legumes to provide initial, temporary cover for erosion control on disturbed sites.

Toe of dam - The base or bottom of the sloping faces of a constructed dam at the point of intersection with the natural ground surface. A dam has an inside toe (the impoundment or upstream side) and an outside toe (the downgradient side).

Toe of slope - The base or bottom of a slope at the point where the ground surface abruptly changes to a significantly flatter grade.

Topography - General term to include characteristics of the ground surface such as plains, hills, mountains, degree of relief, steepness of slopes, and other physiographic features.

Topsoil - The dark-colored surface layer or A horizon of a soil. When present it ranges in depth from a fraction of an inch to 2 or 3 ft.; equivalent to the plow layer of cultivated soils. Commonly used to refer to the surface soil layer(s), enriched in organic matter and having textural and structural characteristics favorable for plant growth.

Trash rack - A structural device used to prevent debris from entering a pipe spillway or other hydraulic structure.

Turbidity - Cloudiness of a liquid, caused by suspended particles (silt, clay, organic material, plankton etc.) that cause light rays to be scattered and absorbed rather than transmitted in straight lines through a sample. Small clay particles known as colloids remain in suspension for long periods of time and are a major contributor to turbidity where they exist.

Turf - Surface soil supporting a dense growth of grass and associated root mat.

Turf reinforcement mat (TRM) – a rolled erosion control product composed of non-degradable synthetic fibers, filaments, nets, wire mesh and/or other elements, including degradable components, designed to impart immediate erosion protection, enhance vegetation establishment and provide long-term erosion control by permanently reinforcing vegetation during and after establishment.

Unified soil classification system - A classification system based on the identification of soils according to their particle size, gradation, plasticity index, and liquid limit.

Uniform flow - A state of steady flow when the mean velocity and cross-sectional area remain constant in all sections of a reach.

Vegetative stabilization - Protection of erodible or sediment-producing areas with: permanent seeding, producing long-term vegetative cover, short-term seeding, producing temporary vegetative cover, or sodding, producing areas covered with a turf of a perennial sod-forming grass.

Watercourse - A definite channel with bed and banks within which concentrated water flows, either continuously or intermittently.

Water quality - A term used to describe the chemical, physical, and biological characteristics of water, usually in respect to its suitability for a particular purpose.

Waters of the State - [of Alabama] means waters of any river, stream, watercourse, pond, lake, coastal, groundwater or surface water, wholly or partially within the State, natural or artificial. This does not include waters which are entirely confined and retained completely upon the property of a single individual, partnership or corporation unless such waters are used in interstate commerce", Code of Alabama 1975, § 22-22-1(b)(2), as amended. Waters "include all navigable waters" as defined in 33 U.S.C. § 1362(7), as amended, which are within the State of Alabama.

Watershed - The region drained by or contributing water to a stream, lake, or other body of water.

Watershed area - The area of all land and water within the confines of a drainage divide.

Wattle (also referred to as a sediment retention fiber roll) – a manufactured device of a filler material encapsulated within a flexible containment material such as natural fiber, straw, or recycled products. Wattles are utilized in sediment and flow control applications such as sediment barriers, inlet protection and small sediment traps.

Weir - A device for measuring or regulating the flow of water.

Wetland - Areas that are inundated or saturated by surface or ground water at a frequency and duration sufficient to support, and that under normal circumstances do support, a prevalence of vegetation typically adapted for life in saturated soil conditions (from Army Corps of Engineers 1987 Wetlands Delineation Manual).

References and Other Resources

Documents Used as Resources in Updating the Alabama Handbook

These documents were used by the authors in developing the handbook. Some drawings and sketches were copied without any changes except page numbers.

Erosion Control Technology Council. <http://www.ectc.org>.

Georgia Soil and Water Conservation Commission, Manual for Erosion and Sediment Control in Georgia, 2016 Edition.

Maryland Department of the Environment Water Management Administration, Maryland Stormwater Design Manual Volumes I & II, October 2000, Revised May 2009.

Mid-American Association of Conservation Districts, 1999. Protecting Water Quality – A field guide to erosion, sediment and stormwater best management practices for development sites in Missouri and Kansas.

North Carolina Department of Environment, Health, and Natural Resources, Division of Land Resources. Erosion and Sediment Control Planning and Design Manual, March 2009.

Pirone, 1978. Tree Maintenance.

Pirone, 1979. Tree Maintenance.

U.S.D.A. – Natural Resources Conservation Service. Alabama Field Office Technical Guide.

Documents Available Electronically to Use in Designing Best Management Practices

Alabama Handbook for Erosion Control, Sediment Control and Stormwater Management on Construction Sites and Urban Areas, September 2022.

<https://alabamasoilandwater.gov/alesc/>

Best Management Practices: An Owner's Guide to Protecting Archaeological Sites

<https://files.floridados.gov/media/30867/handbook.pdf>

Low Impact Development Handbook for the State of Alabama. Alabama Department of Environmental Management, Alabama Cooperative Extension System and Auburn University,

<https://adem.alabama.gov/programs/water/waterforms/LIDHandbook.pdf>

TR-55, Urban Hydrology for Small Watersheds

<https://www.nrcs.usda.gov/wps/portal/nrcs/detailfull/national/water/?cid=stelprdb1042901>

Stream Corridor Restoration

https://www.nrcs.usda.gov/Internet/FSE_DOCUMENTS/stelprdb1044574.pdf

Soil Bioengineering for Upland Slope Protection and Erosion Reduction

<http://directives.sc.egov.usda.gov/OpenNonWebContent.aspx?content=17555.wba>

Other Related Documents Available Electronically

Alabama Department of Environmental Management Regulations

<http://adem.alabama.gov/alEnviroRegLaws/default.cnt>

Alabama Department of Environmental Management Construction General Permit

<http://adem.alabama.gov/programs/water/constructionstormwater.cnt>

Alabama Department of Environmental Management Coastal Program

<http://adem.alabama.gov/programs/coastal/default.cnt>

Federal Highway Department Hydraulic Publications

<https://www.fhwa.dot.gov/engineering/hydraulics/>

Resource Agencies

The following agencies have a role in various aspects of land disturbances.

Alabama Department of Environmental Management Field Operations Division Offices

ADEM Montgomery Office

1400 Coliseum Boulevard
Montgomery, AL 36110-2400
(334) 271-7700

Mailing Address

P.O. Box 301463
Montgomery, AL 36130-1463

Central Laboratory/Field Operations

1350 Coliseum Boulevard
Montgomery, AL 36110-2412

Birmingham Field Office

110 Vulcan Road
Birmingham, AL 35209
(205) 942-6168

Decatur Field Office

2715 Sandlin Road, S.W.
Decatur, AL 35603
(256) 353-1713

Mobile Central Field Office

2204 Perimeter Road
Mobile, AL 36615
(251) 450-3400

Mobile Coastal Field Office

3664 Dauphin Street, Suite B
Mobile, AL 36608
(251) 304-1176

Alabama Historical Commission
468 South Perry Street
P.O. Box 300900
Montgomery, Alabama 36130-0900
334-242-3184
<https://ahc.alabama.gov>

Alabama Soil and Water Conservation Committee
P.O. Box 304800
Montgomery, Alabama 36130-4800
Phone: 334/242-2620
Fax: 334-242-0551
<https://alabamasoilandwater.gov/>

Geological Survey of Alabama
420 Hackberry Lane
Tuscaloosa, Alabama 35401
(205) 349-2852
<https://www.gsa.state.al.us/>

Soil and Water Conservation Districts

A Soil and Water Conservation District is located in each county and usually listed in the phone book with the other local government offices.

U.S. Army Corps of Engineers

Mobile District

P.O. Box 2288
Mobile, AL 36628-0001
Phone: 251-690-2511

Nashville District

Estes Kefauver Federal Building & Courthouse Annex
801 Broadway
Nashville, TN 37214-2660
Phone: 615-736-7161

U.S. Dept. of Agriculture – Natural Resources Conservation Service

Alabama State Office
3381 Skyway Drive
P. O. Box 311
Auburn, AL 36830
1-800-342-9893
<https://www.nrcs.usda.gov/wps/portal/nrcs/site/al/home/>

In addition, a Field Office of the Natural Resources Conservation Service is located in most counties (if not, a contact can be made through the local soil and water conservation district office)

U.S. Dept. of Interior - Fish and Wildlife Service
Daphne Ecological Services Field Office
P.O. Drawer 1190
1208-B Main Street
Daphne AL 36526
251-441-5181 phone
251-441-6222 fax
<http://www.fws.gov/daphne/>

US Environmental Protection Agency
Region 4
Sam Nunn Atlanta Federal Center
61 Forsyth Street, SW #9
Atlanta, GA 30303
404-562-9900
1-800-241-1754
<http://www2.epa.gov/aboutepa/about-epa-region-4-southeast>

CAD Drawings

Drawings prepared using AutoCADD Civil 3D and located in related practices.

Check Dam – Wattle	
Inlet Protection – Block and Gravel 1	
Inlet Protection – Block and Gravel 2	
Inlet Protection – Sand Bag	
Inlet Protection – Silt Fence	
Inlet Protection – Wattle	
Figure BFB-1	Typical Brush Fabric Barrier
Figure CD-1	Profile and Cross-Section of Typical Rock Check Dams
Figure CD-2	Profile of Typical Rock Check Dams
Figure CD-3	Wattle Check Dam (ditch check)
Figure CD-5	Silt Fence Check Dam Cross-Section
Figure CD-6	Silt Fence Check Dam Plan View
Figure CD-8	Sand Bag Check Dam Cross-Section
Figure CD-9	Sand Bag Check Dam Plan View
Figure CEP-1	Gravel Construction Exit
Figure CEP-2	Construction Exit with Wash Rack
Figure DS-1	Straight Pipe Structure
Figure DS-2	Pipe Drop Structure
Figure DSF-1	Typical Dune Erosion Control System with Sand Fence
Figure DV-2	Typical Diversions Detail
Figure DW-1	Typical Dune Walkover System
Figure GS-1	(Vol. II) Typical Trapezoidal Grass-lined Channel
Figure GS-1	Typical Grass Swale Cross section
Figure OP-4	Paved Channel Outlet
Figure PP-1	Typical Section of Porous Pavement with Buried Stone Reservoir
Figure PP-2	Typical Porous Pavement Design
Figure PV-1	Fencing and Armoring
Figure PV-2	Tree Well
Figure PV-3	Tree Well Detail
Figure PV-4	Tree Wall Detail
Figure RD-1	Typical Front View of Rock Filter Dam
Figure RD-2	Typical Section of Rock Filter Dam
Figure SB-3	Silt Fence-Type A
Figure SB-4	Type A Silt Fence Overlap
Figure SB-5	Silt Fence - Type B
Figure SB-6	Silt Fence Installation Details for Type B
Figure SBN-1	Porous Baffle in a Sediment Basin
Figure SBN-2	Cross-Section of a Porous Baffle in a Sediment Basin
Figure SBN-5	Excavated Grass Spillway Views
Figure SBN-6	Example of a Sediment Basin with a Skimmer Outlet and Auxiliary Spillway
Figure SD-1	Details of Typical Subsurface Drain Construction
Figure SD-2	Details of Subsurface Drain Construction

Figure SDB-1	Typical Stormwater Detention Basin / Sediment Basin Components
Figure SDB-2	Typical Dry Stormwater Detention Basin Components
Figure SDB-3	Typical Wet Stormwater Detention Basin Components
Figure SDC-1	Typical Stream Diversion Channel Layout
Figure SOD-2	Typical Installation of Grass Sod
Figure SOD-3	Installation of Sod in Areas with Channel Flows
Figure SP-1	Vegetative Zones for Streambank Protection
Figure TP-1	Tree Planting Diagram
Figure TSC-1	Culvert Stream Crossing
Figure TSD-1	Typical Temporary Slope Drain Detail
Figure TSD-2	Flared End-Section Detail
Figure TSD-3	Flared End-Section Details (continued)

Local Information

Alabama Handbook for

Erosion Control, Sediment Control and Stormwater Management on Construction Sites and Urban Areas (The Blue Book)

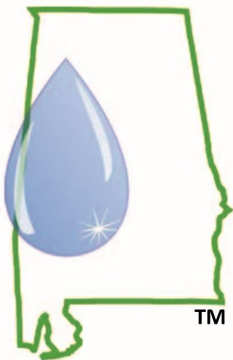

Volume 2

Installation, Maintenance, and Inspection of
Best Management Practices

2022

Alabama Soil and Water Conservation Committee
Montgomery, Alabama

Table of Contents

Table of Contents	i
Introduction and Summary of Changes	iii
Chapter 1: Erosion, Sedimentation and Stormwater Processes	1
Chapter 2: Plans for Erosion control, Sediment Control And Stormwater Management	5
Chapter 3: Installation and Maintenance Of Best Management Practices	7
Site Preparation	
Construction Exit Pad (CEP)	9
Land Grading (LG)	13
Topsoiling (TSG)	17
Surface Stabilization	
Chemical Stabilization (CHS)	21
Dune Sand Fence (DSF)	25
Dune Vegetation Planting (DVP)	29
Dune Walkover (DW).....	33
Dust Control (DC)	37
Erosion Control Blanket (ECB).	41
Groundskeeping (GK).....	45
Mulching (MU)	51
Permanent Seeding (PS).....	55
Preservation of Vegetation (PV)	63
Retaining Wall (RW)	67
Shrub, Vine and Groundcover Planting (SVG)	71
Sodding (SOD)	77
Temporary Seeding (TS)	83
Tree Planting on Disturbed Areas (TP).....	89
Runoff Conveyance	
Check Dam (CD)	95
Diversion (DV)	99
Drop Structure (DS).....	103
Grass Swale (GS).....	107
Lined Swale (LS)	111
Outlet Protection (OP)	115

Riprap-lined Swale (RS)	119
Subsurface Drain (SD)	123
Temporary Slope Drain (TSD)	127
Sediment Control	
Brush/Fabric Barrier (BFB)	131
Filter Strip (FS)	135
Floating Turbidity Barrier (FB)	141
Flocculant	145
Inlet Protection (IP).....	149
Rock Filter Dam (RD)	157
Sediment Barrier (SB)	161
Sediment Basin (SBN).....	167
Stormwater Management	
Bioretention Area (BA).....	175
Porous Pavement (PP).....	181
Stormwater Detention Basin (SDB)	187
Stream Protection	
Buffer Zone (BZ).....	193
Channel Stabilization (CS)	197
Stream Diversion Channel (SDC)	203
Streambank Protection (SP).....	209
Temporary Stream Crossing (TSC)	215
Chapter 4: Inspection of Construction Sites	221

Introduction

The *Alabama Handbook for Erosion Control, Sediment Control and Stormwater Management on Construction Sites and Urban Areas* (The Blue Book) provides guidance for preventing or minimizing the related problems of erosion, sediment and stormwater on construction sites associated with non-agricultural development.

This latest update of the Blue Book corrected some misspellings and made changes to practices based on recent research of The Auburn University Stormwater Research Facility. The main changes were to the Sediment Barrier practice. A Summary of Changes since the 2018 Blue Book are included at the end of the introduction.

Volume 1 provides essential information that can be used by trained planners and designers to develop sound plans and designs.

Volume 2 provides information that can be used by developers, contractors and inspectors to install and maintain the measures, commonly referred to as Best Management Practices.

Potential Handbook users should recognize that plans, designs, installation and maintenance are integral and related aspects of site development. Each aspect has a role in sound development and protection of natural resources. With this viewpoint, we recognize that both volumes of the Handbook contain information necessary for site stewardship. Depending upon their role in the development process, users may need one or both of the volumes.

Yes, regulations are necessary for several reasons, but a stewardship ethic that recognizes that our natural resources should be protected during and after development should be a mindset of each party involved in land development. This approach puts the tasks of erosion control, sediment control and stormwater management in a proactive mode which is essential to minimize negative impacts during development.

The Alabama Soil and Water Conservation Committee encourages those involved in construction activities to voluntarily and aggressively embrace sound technology and practice strong stewardship of our land and water resources. This approach maximizes benefits to those involved and protects the environment.



Dr. William E. Puckett, Executive Director
Alabama Soil and Water Conservation Committee

Summary of Changes

Purpose: To outline significant changes since the 2018 Volume 2 Blue Book was published.
(Minor edits and formatting changes are not listed).

Major Changes:

1. Chapter 3, Check Dam, page 96: Changed the recommendation of sod staple spacing for a Wattle Check Dam from 10-inch centers to approximately 6-inch centers on each side of the wattle.
2. Chapter 3, Lined Swale, page 111: Included tied concrete block mats as a material for lining.
3. Chapter 3, Inlet Protection, page 153: Changed the recommendation of sod staple spacing for a Wattle Inlet Protection from 10-inch centers to approximately 6-inch centers on each side of the wattle.
4. Chapter 3, Sediment Barrier, page 162: In the Silt Fence Installation section, noted that an off-set installation with a trench or slice is now the preferred method of installation. Also added for the proper installation of the overflow/dewatering device and splash pad when specified.
5. Chapter 3, Deleted the practice Sediment Trap.

New Content:

1. Chapter 3, Mulching, page 52: Added the sentence to verify wildlife friendly netting when specified.
2. Chapter 3, Sodding, page 80: Added the sentence to consider the use of wildlife friendly netting.
3. Chapter 3, Temporary Seeding, page 86: In the Hydroseeding Section, added the sentence “Whenever possible, it is often best to incorporate lime and fertilizer with a disk”.
4. Chapter 3, Drop Structure, page 105: Added the sentence “A sand drainage diaphragm should be completed along with the fill material”.
5. Chapter 3, Subsurface Drain, page 124: In the Trench Excavation section, added the sentence “Ensure trenching meets OSHA requirements”.
6. Chapter 3, Subsurface Drain, page 124: In the Installation section added coarse sand to the filter medium.
7. Chapter 3, Sediment Barrier, page 163: Added Figure SB-2 for Type A Splice.
8. Chapter 3, Sediment Basin, page 169: Introduced the term “standing pool”. Added the statement “Ensure the schedule 40 connecting pipe is at least 1.5 times the depth the skimmer should operate”.

Major Clarifications:

1. Chapter 3, Groundskeeping, page 46: Added that petroleum-based activities should be as far away as possible from Waters of the State and conveyances.
2. Chapter 3, Groundskeeping, page 46: Added that Mud Tracking cleanup should only be done using “dry” methods.
3. Chapter 3, Groundskeeping, pages 46-47: Clarified concrete truck washout containment.
4. Chapter 3, Groundskeeping, page 47: Added that waste containers should be as far away as possible from Waters of the State and conveyances.
5. Chapter 3, Permanent Seeding, page 59: Added footnote 1 to Table PS-1, “DO NOT USE Seeding Rates as part of a mixture unless shown as a mixture in this table”.
6. Chapter 3, Temporary Seeding, page 86: Added footnote 1 to Table TS-1, “DO NOT USE Seeding Rates as part of a mixture”.
7. Chapter 3, Filter Strip, page 139: Added footnote 1 to Table FS-1, “DO NOT USE Seeding Rates as part of a mixture unless shown as a mixture in this table”.
8. Chapter 3, page 179 and 181: Corrected the URL to the LID Handbook for Alabama.
9. Chapter 4, Inspection of Construction Sites, pages 226-227: Updated ADEM Form 23.

Chapter 1

Erosion, Sedimentation and Stormwater Processes (An Overview)

This chapter presents a simple overview of the processes referred to as erosion, sedimentation and stormwater. If in-depth information is needed on these subjects, other references, including Volume I, should be used.

Processes

Erosion is the process by which the land surface is worn away by the action of water, wind, ice or gravity. Water-related erosion is the primary problem in developing areas of Alabama.

With the exception of shorelines and stream channels where erosion may be rapid and catastrophic, geologic erosion occurs at very slow rates. This natural erosion process, which has taken place over millions of years, has probably occurred at rates comparable to erosion in our forests that have no current disturbances.

The erosion accelerated by the disturbances of humans is referred to as “accelerated erosion” and can be significant and create adverse impacts.

Sedimentation is the process that describes soil particles settling out of suspension. Associated with sedimentation is **turbidity**, a cloudy or muddy condition of water usually resulting from eroded soil suspended in the water column.

Stormwater refers to the water flowing over the land during and immediately following a rainstorm.

Factors Influencing Erosion, Sedimentation and Stormwater

Erosion is influenced primarily by climate, topography, soils, and vegetative cover.

Climate includes rainfall, wind and temperature. The frequency, intensity and duration of rainfall are the principal aspects of rainfall influencing the volume of runoff and sediment (potential) from a given area. As the volume and intensity of rainfall increase, the ability of water to detach and transport soil particles increases. When storms are frequent, intense, and of long duration, the potential for erosion of bare soils is high. Temperature has a major influence on soil erosion. Frozen soils are relatively erosion resistant. However, bare soils with

high moisture content are subject to uplift or "spew", by freezing action, and are usually very easily eroded upon thawing.

Topography includes the shape and slope characteristics of an area or watershed and influences the amount and duration of runoff. The greater the slope length and slope gradient, the greater the potential for runoff, erosion and sediment delivery.

Soils factors include soil texture, soil structure, organic matter content and permeability. In addition, in many situations compaction is significant. These aspects greatly determine the erodibility of soil.

Soils containing high percentages of sand and silt are the most susceptible to detachment because they lack inherent cohesiveness characteristics. However, the high infiltration rates of sands either prevent or delay runoff except where overland flow is concentrated. Clearly, well-graded and well-drained sands are usually the least erodible soils in the context of sheet and rill erosion.

Clay and organic matter act as a binder to soil particles thus reducing erodibility. As the clay and organic matter content of soils increase, the erodibility decreases. But, while clays have a tendency to resist erosion, they are easily transported by water once detached.

Soils high in organic matter resist raindrop impact and the organic matter also increases the binding characteristics of the soil.

Sandy and silty soils lack inherent cohesiveness and are highly susceptible to gully erosion where flows concentrate on slopes and in channels.

Vegetative cover is an extremely important factor in reducing erosion at a site. It will:

- a. Absorb energy of raindrops.
- b. Bind soil particles.
- c. Slow velocity of runoff water.
- d. Increase the ability of a soil to absorb water.
- e. Remove subsurface water between rainfall events through the process of evapotranspiration.

By limiting the amount of vegetation disturbed and the exposure of soils to erosive elements, soil erosion can be greatly reduced.

Sedimentation is influenced by the nature of the suspended particles and by the velocity of the runoff.

Gravel and sand, the heavier and larger particles, settle out more rapidly than silt and clay particles.

Silt and clay particles are easily transported and settle out very slowly.

Slower *velocities* associated with flatter terrain or structures such as silt fence and sediment basins dissipate the energy in runoff and allow sediment to be deposited. However, it is difficult, and perhaps impossible in some instances, to totally eliminate the transport of the clay and silt particles even with the most effective sediment control practices. It is the clay particles that are suspended in the runoff that have the most effect on turbidity and have the most adverse impacts on water quality.

Stormwater (rate and total flow) is influenced by climate, soils, geology, topography, vegetative cover and, most importantly, land use.

Runoff intercepted by *vegetation* and evaporated or transpired is lost from runoff. A small portion of the water that infiltrates into the soil and groundwater is delivered to streams as delayed flow and does not contribute directly to peak stormwater runoff.

As an area becomes *urbanized*, the peak rate of runoff and volume of runoff increase. These effects are caused by: 1) a reduction in the opportunity for infiltration, evaporation, transpiration and depression storage; 2) an increase in the amount of imperviousness; 3) modification of the surface drainage pattern, including the associated development of stormwater management facilities.

Impacts of Land Development on Water Quality and Water Quantity

Of primary importance to water quality is the "first flush" in a watershed. This term describes the combined actions that erosion, sedimentation and stormwater have on accumulated pollutants (sediment, pesticides, fertilizers, animal wastes, petroleum products and heavy metals). In the early stages of runoff the land surfaces are flushed by the stormwater. This flushing creates a loading of pollutants. Extensive studies in Florida have determined that the first flush equates to the first one inch of runoff which carries 90% of the pollution load from a storm (USGS, 1984). Other studies have suggested that the first one-half inch of runoff provides the "first flush".

The "first flush" is dependent upon several factors unique to each site, i.e. percent impervious surface, condition of vegetative cover and soil permeability. "First flush" effects generally diminish as the size of the drainage basin increases and the amount of impervious area decreases.

The potential off-site effects of land development include increased flooding, accelerated erosion of stream systems, increased sediment deposition in both streams and floodplains and adverse impacts on the biological communities associated with the streams and floodplains.

Each progression toward more intensive land use tends to disrupt the ongoing natural processes which protect and preserve water quality and water quantity. Therefore, to ensure future protection of water resources, it is imperative that land uses be managed in a responsible way.

As we reflect on the processes and the potential impact, we recognize the importance of sound site planning, timely and proper installation of the measures planned and the need for long-term maintenance of measures that sustain site stabilization.

We see an increasing need for preserving existing vegetation at construction sites either as long as the project plan permits or, if planned for permanent retention, protecting during the duration of the construction project. Preserving vegetation and adopting low impact development practices will significantly help offset the potential adverse impacts of using our landscapes more intensely.

If the best available technology is used for planning, design, installation and maintenance of erosion and sediment control and stormwater management the impacts of land development will be minimized.

Chapter 2

Plans for Erosion Control, Sediment Control and Stormwater Management (An Overview)

The purpose of this chapter is to provide an overview of erosion control, sediment control and stormwater management (ESC) plans. Plans and practice specifications should be referred to throughout a construction project and are, therefore, important to contractors and inspectors.

Construction plans for site development should include sound plans for erosion control, sediment control and stormwater management. Because of its significance as an indicator of water quality, turbidity should be included in the thought process during planning for erosion and sediment control. Although they may sometimes be discussed separately, erosion control, sediment control and stormwater management are interrelated and when planning occurs the process must conceive a system of practices and measures that consider all three together.

Property owners or operators are responsible for providing sound ESC plans. This is accomplished by using qualified professionals for ESC plan preparation. ESC plan preparation should be an integral part of the facility plan development. Those involved in ESC construction can benefit by understanding some of the basic planning concepts which should be embedded in ESC plans. Such an understanding makes schedules, sequence of installation and maintenance more supportable. These concepts include the following items.

1. Minimize the area disturbed by leaving existing vegetation that does not have to be removed.
2. Minimize the period of bare ground by shortening construction periods and staging a project (dividing the project into sectors that will be done independently of other sectors) when possible.
3. Install practices in a sequence that supports shortened construction periods and permits the use of temporary and permanent seeding when the practices can be most effective.

4. Use perimeter and interior sediment control measures that minimize sediment transport off of the disturbed site.
5. Plan erosion control for all kinds of erosion that may occur depending upon specific site conditions.
6. Give special attention to cut and fill slopes because these are the most difficult to establish effective vegetation.
7. Give special attention to sites that are transected by streams or are in close proximity to streams and wetlands because construction in close proximity to these areas increases the importance of effective erosion and sediment control.
8. Make erosion control plantings at every opportunity.
9. Prevent sediment from leaving a construction site at entrance/exits during muddy periods.
10. Maintain practices to ensure their effectiveness. This includes regular inspections of the practices, the site, adjacent off-site areas and receiving streams.

There are typically two components of an ESC plan: a site plan map showing locations of the planned practices, referred to by most persons as best management practices or BMPs, and a written narrative. It is common to see the written narrative recorded on the site plan map.

ESC plans should contain enough information to ensure that the party responsible for development of a site can install the measures in the correct sequence at the appropriate season of the year. Sufficient information should be included to provide for maintaining the practices and measures during construction and after installation has been completed. A schedule of regular inspections should be set forth to ensure that repairs and maintenance receive appropriate attention and is accomplished.

Associated with ESC plans are designs that show details of the practices. Designs include essential information such as size, shape, elevations and materials for the practices. Designs should be made available at all times for use by contractors during construction.

It is important to recognize that most ESC plans need revising periodically because of a number of reasons such as (a) interruptions by weather or contractual reasons alter the construction schedule, (b) a determination after construction begins that a different combination of practices is needed, and (c) design specifications cannot be met because of unavailability of materials.

For more details on planning concepts and plan preparation, additional information can be found in Volume I (Chapter 2 General Planning Concepts, and Chapter 3 Plan Preparation).

Chapter 3

Installation and Maintenance of Best Management Practices

Site Preparation

Construction Exit Pad (CEP).....	9
Land Grading (LG).....	13
Topsoiling (TSG).....	17

Surface Stabilization

Chemical Stabilization (CHS).....	21
Dune Sand Fence (DSF).....	25
Dune Vegetation Planting (DVP).....	29
Dune Walkover (DW).....	33
Dust Control (DC).....	37
Erosion Control Blanket (ECB).....	41
Groundskeeping (GK).....	45
Mulching (MU).....	51
Permanent Seeding (PS).....	55
Preservation of Vegetation (PV).....	63
Retaining Wall (RW).....	67
Shrub, Vine and Groundcover Planting (SVG).....	71
Sodding (SOD).....	77
Temporary Seeding (TS).....	83
Tree Planting on Disturbed Areas (TP).....	89

Runoff Conveyance

Check Dam (CD).....	95
Diversion (DV).....	99
Drop Structure (DS).....	103
Grass Swale (GS).....	107

Lined Swale (LS).....	111
Outlet Protection (OP).....	115
Riprap-lined Swale (RS)	119
Subsurface Drain (SD).....	123
Temporary Slope Drain (TSD).....	127
Sediment Control	
Brush/Fabric Barrier (BFB)	131
Filter Strip (FS).....	135
Floating Turbidity Barrier (FB).....	141
Flocculant (FL)	145
Inlet Protection (IP)	149
Rock Filter Dam (RD).....	157
Sediment Barrier (SB).....	161
Sediment Basin (SBN).....	167
Stormwater Management	
Bioretention Area (BA)	175
Porous Pavement (PP)	181
Stormwater Detention Basin (SDB).....	187
Stream Protection	
Buffer Zone (BZ)	193
Channel Stabilization (CS).....	197
Stream Diversion Channel (SDC)	203
Streambank Protection (SP)	209
Temporary Stream Crossing (TSC).....	215

Construction Exit Pad (CEP)



Practice Description

A construction exit pad is a stone base pad or manufactured product designed to provide a buffer area where mud and caked soil can be removed from the tires of construction vehicles to avoid transporting it onto public roads. This practice applies anywhere traffic will be leaving a construction site and move directly onto a public road or street.

Typical Components of the Practice

- Site Preparation
- Grading
- Stabilization with Geotextile Fabric (where needed to provide stability)
- Aggregate Placement
- Construction Verification
- Maintenance

Construction

Prior to start of construction, temporary gravel construction entrance/exit pads should be designed by a qualified design professional and plans and specifications should be available to field personnel.

Site Preparation

Remove all vegetation and other unsuitable material from the foundation area.

Grading

Grade and crown the area for positive drainage.

Utilize a diversion to direct any surface flow away from the construction exit pad.

Install pipe under the pad if needed to maintain drainage ditches along public roads.

Divert all construction exit pad runoff and drainage to a sediment trap or basin.

Stabilization

If project specified, or if wet conditions or soft soils are anticipated, place non-woven geotextile fabric on the graded foundation prior to placing the aggregate to improve stability.

Aggregate Placement

Place specified stone size to lines and grade shown on plans. Leave surface smooth and sloped for drainage.

Construction Verification

Check all components during construction and installation to ensure that specifications are being met for the components.

Common Problems

Consult with a qualified design professional if any of the following occur:

- Inadequate runoff control and sediment washes onto public road: install diversions or other runoff control measures.
- Ruts and muddy conditions develop as stone are pressed into soil; increase stone size or pad thickness, or add geotextile fabric.
- Pad too short for heavy construction traffic: consult design professional about extending pad to the necessary length.

Maintenance

Remove large chunks of mud or caked soil from construction exit pad daily to minimize sediment buildup.

Inspect stone pad and sediment disposal area weekly and after storm events or heavy use.

Reshape pad as needed for drainage and runoff control.

Top-dress with clean specified stone as needed to maintain effectiveness of the practice.

Immediately remove mud or sediment tracked or washed onto public road.
Repair any broken road pavement immediately.

Remove unneeded exit pad materials from areas where permanent vegetation will be established.

This Page Intentionally Left Blank

Land Grading (LG)



Practice Description

Land grading is reshaping of the ground surface to provide suitable topography for buildings, facilities, and other land uses, to control surface runoff, and to minimize soil erosion and sedimentation both during and after construction. This practice applies to sites where the existing topography must be modified to prepare for another land use, or where adapting proposed development to the existing landscape can reduce the erosion potential of the site and the cost of installing erosion and sediment control measures. In some instances, other practices such as diversions or benches can be used to reduce the length of continuous slopes and reduce erosion potential.

Typical Components of the Practice

- Scheduling
- Runoff Conveyance
- Sediment Control
- Site Preparation
- Grading
- Erosion Control
- Construction Verification
- Maintenance

Construction

Prior to start of construction, the site grading plan should be designed by a qualified design professional. The grading plan should show disturbed areas, cuts, fills, and finished elevations for all graded areas. Plans and specifications should be referred to by field personnel throughout the construction process.

Scheduling

Grading activities should be scheduled to minimize the area disturbed.

Runoff Conveyance

Runoff from disturbed areas should be controlled at the outlets with proper runoff conveyance practices, such as drop structures, riprap-lined swales, or rock outlets.

Sediment Control

Appropriate sediment control measures should be installed to minimize sediment delivery off-site until other measures can be installed to prevent erosion. The measures should be installed as specified and in the sequence shown in the design plan.

Site Preparation

Determine exact location of underground utilities.

Remove and stockpile topsoil (see Topsoiling practice).

Clear and grub areas by removing trees, vegetation, roots and other debris. Check fill to make sure it does not contain brush, rubbish, oversized rocks or other objectionable material.

Grading

Place fill in layers and compact as specified by the grading plan

Construct slope breaks as shown on the grading plan.

Keep diversions and other water conveyance measures free of sediment during all phases of development, including grading.

Install subsurface drains (see Subsurface Drains practice) in areas where seepage interferes with the grading operations, or where required to improve slope stability or soil bearing capacity.

The final trip over slopes using equipment with tracks should be made up-and-down the slopes to establish cleat marks on the contour (“tracking”).

Erosion Control

Use temporary stabilization measures on graded areas when work is to be interrupted or delayed for 14 calendar days or longer. A shorter period may be appropriate in critical situations (for example, steep bare slopes close to the drainageway that discharges into sensitive waters).

Stabilize graded areas that have “final grading completed” within 10 working days. Use permanent seeding or other appropriate stabilization measures. If grading is completed out of season for the desired vegetation, a temporary planting may be made first and the permanent planting made later during the recommended planting period.

Construction Verification

Check all finished grades for conformance with grading plan and correct as necessary.

Common Problems

Consult with a qualified design professional if any of the following occur:

- Variations in topography on-site indicate grading plan will be ineffective or unfeasible.
- Seepage is encountered during construction. It may be necessary to install drains.
- Subgrade is soft or has high organic content and can hinder proper compaction of fill. It may be necessary to undercut and replace unsuitable subgrade soil.
- Design specifications for sediment control measures, seed variety, seeding dates or other erosion control measures or materials cannot be met. Substitutions may be required. Unapproved substitutions could result in erosion and lead to failure of sediment and erosion control measures.

Maintenance

Periodically check all graded areas and the related erosion and sediment control practices for damage by equipment and especially after heavy rainfalls for damage by runoff. Repair silt fences and other temporary sediment control measures. Clean sediment out of adjacent diversions and other structures as needed. Repair any failures that occur in surface stabilization measures such as plantings.

This Page Intentionally Left Blank

Topsoiling (TSG)



Practice Description

Topsoiling is the removal of a desirable soil surface, referred to as topsoil, at a site prior to construction and using it on areas to be vegetated. Topsoiling a site usually improves the quality of the plant growth medium at the site and increases the likelihood of successful plant establishment and performance. This practice applies to sites that are to be disturbed by excavation, compaction, or filling, and to other areas where the subsoil is unsuitable for plant growth.

Typical Components of the Practice

- Scheduling
- Removal of Topsoil (Stripping)
- Stockpiling
- Temporary Erosion Control
- Spreading Topsoil
- Construction Verification
- Maintenance

Construction

Prior to start of construction, topsoiling should be planned by a qualified design professional and incorporated in the development plan. The grading plan should

show disturbed areas and the stockpile area(s). Areas to receive topsoil after grading should be included in the erosion and sediment control plan. Plans and specifications should be referred to throughout the construction process.

Scheduling

Stripping should be scheduled to precede or be done concurrently with land grading.

Stripping

Strip topsoil from areas that will be disturbed by excavation, filling or compaction by equipment. Locations and depths to remove the topsoil should be based on the design plan. In the absence of details in the plan, determine depth of stripping by taking soil cores at several locations within each area to be stripped and remove the friable and loamy surface (typically 4" to 6"). Stumps, roots, trash, noxious weeds, and soils containing toxic chemicals should be removed separately and disposed of according to locally accepted procedures.

Stockpiling

Stockpile topsoil at the site(s) identified in the design plan. In the absence of details in the plan locate the stockpile so that natural drainage is not obstructed. Avoid stockpiling on steep slopes. Side slopes of stockpiles should not exceed 2:1. Use silt fences or other barriers where necessary to complement temporary erosion control and prevent sediment movement.

Temporary Erosion Control

Protect stockpile as specified in the design plan. In the absence of details in the plan use temporary seeding as soon as possible, but not more than 14 working days after formation of the stockpile. Mulching may be substituted for temporary seeding on stockpiles that will be used within 2 months. If stockpiles will not be used within 12 months, they should be stabilized with permanent vegetation to control erosion and weed growth.

Spreading Topsoil

Immediately prior to spreading topsoil, loosen the subgrade of the site to receive the topsoil by disking or scarifying to a depth of at least 2" to ensure bonding of the topsoil and subsoil.

Uniformly spread topsoil to a lightly compacted depth of 4" or greater. For long-term growth of vegetation without irrigation, minimum soil depth (subsoil and topsoil) should be 8" to 12" over loose sand or rock fragments, and 24" of soil depth is needed over bedrock. Established grades should be maintained according to the approved plan and should not be altered by adding topsoil.

Avoid spreading when either soil or subgrade is wet or frozen.

Construction Verification

Check all components of topsoiling that occur on the construction site to ensure that specifications are being met for the components.

Common Problems

Consult with qualified design professional if any of the following occur:

- Depth of surface being stripped is significantly different than anticipated.
- Topsoil appears to contain contaminants.
- Topsoil appears too compacted during spreading; may need to loosen by disking or scarifying.

Maintenance

Inspect topsoiled areas frequently until vegetation is established.

Repair eroded or damaged areas and revegetate.

Repair sloughing on steep slopes—remove topsoil, roughen subgrade and respread topsoil. Consult with qualified design professional if drainage (wetness caused by seepage) or shallowness to bedrock (less than 24”) is involved.

This Page Intentionally Left Blank

Chemical Stabilization (CHS)



Photo courtesy of Sunshine Supplies, Inc.

Practice Description

Chemical Stabilization erosion control involves the use of products, including soil binders that help to hold the soil in place, thereby reducing soil particle detachment and short-term erosion caused by water and wind. Water-soluble polyacrylamide (PAM) is often used for this purpose. Other products may also provide this benefit. The products are typically applied with temporary seeding and or mulching on areas where the timely establishment of temporary erosion control is so critical that seedings and mulching need additional reinforcement.

Typical Components of the Practice

- Site Preparation
- Equipment Preparation
- Chemical Application
- Installation Verification
- Maintenance

Application

Prior to the start of construction, the application of chemicals for surface stabilization should be designed by a qualified design professional and plans and specifications should be available to field personnel.

The application should conform to the design and specifications provided in the plans.

Site Preparation

Prepare site following design and specifications.

Equipment Preparation

When using chemicals that can clog a liquid application system, pump a surfactant through the injection system before and after injecting concentrated chemicals into the sprinkler irrigation system to prevent valves and tubing from clogging.

Chemicals used in hydroseeding applications should be the last additive to the mix.

After use, rinse all mixing and application equipment thoroughly with water to avoid formation of residues. Rinse residue should be applied to soil areas needing stabilization.

Chemical Application

Site testing for a product should be conducted before application to verify the product performance. Test reports (recommendations) should be supplied to the design professional and contractor before product application.

Toxicity reports should be provided by the supplier to the contractor before application of a product (this is to assure that applications from the recommended product will be non-toxic).

Chemicals should be mixed and/or applied in accordance with all Occupational Safety and Health Administration (OSHA) Material Safety Data Sheet requirements and the manufacturer's recommendations for the specified use conforming to all federal, state, and local laws, rules and regulations.

Emulsion batches should be mixed following recommendations of a testing laboratory that determines the proper product and rate to meet site requirements.

Never add water to chemicals, but instead add the chemical slowly to water.

Dry form (powder) may be applied by hand spreader or a mechanical spreader.

Mixing with dry silica sand will aid in spreading. Pre-mixing of dry form chemicals into fertilizer, seed or other soil amendments is allowed when specified in the design plan. Application method should ensure uniform coverage to the target area.

If near a water body, observe the identified Buffer Zone for the job.

Installation Verification

Check all components of the practice during installation to ensure that specifications are being met.

Common Problems

Consult with a qualified design professional if any of the following occur:

- Problems with application equipment clogging.
- Application specifications for chemicals cannot be met; alternatives may be required. Unapproved application techniques could lead to failure.
- Visible erosion occurs after application.

Maintenance

An operation and maintenance plan must be prepared for use by the operator responsible for chemical application. Plan items should include the following items:

- Reapply chemicals to disturbed or tilled areas that require continued erosion control.
- Maintain equipment to provide uniform application rates.
- Rinse all mixing and application equipment thoroughly with water to avoid formation of residues and discharge rinse water to soil areas where stabilization may be helpful.
- Down gradient deposition from the use of chemicals may require periodic sediment removal to maintain normal functions of sediment control practices.

This Page Intentionally Left Blank

Dune Sand Fence (DSF)



Photo courtesy of Alabama Department of Environmental Management

Practice Description

A dune sand fence is a temporary barrier consisting of wooden slots installed across a dune landscape perpendicular to the prevailing wind. Dune sand fence reduces wind velocity at the ground surface and traps blowing sand. Sand fencing and appropriate plant materials can be used to build frontal ocean dunes to control beach erosion and flooding behind frontal dunes from wave over wash. Sand fence is applicable where sand can be trapped to enhance dune vegetation.

Typical Components of the Practice

- Scheduling
- Site Preparation
- Installation
- Construction Verification
- Maintenance

Note: To attain maximum benefits of a dune sand fence, the beach/dune area designated for sand trapping should be renourished with appropriate plantings before the installation of the dune sand fence (in the absence of a dune vegetation planting plan, see Dune Vegetation Planting for guidance).

Construction

Prior to start of construction, sand fence should be designed by a qualified design professional and necessary federal, state, and local permits should be obtained. Plans and specifications should be referred to by field personnel throughout the construction process.

Attempt to schedule the installation of dune sand fence during the recommended planting periods for the associated dune vegetation plantings that are planned.

Site Preparation

Determine if underground utilities exist in the area and if they do, determine their locations so that fence lines and placement of stakes can be selected where utilities will not be damaged.

Remove any obstacles that will prevent installation of the fence.

Installation

Install the fence according to details in the design plan. If design details are not available guidelines should be obtained from the Alabama Department of Environmental Management Coastal Zone Program office or the following items should be considered for guidance.

Establish the position for the sand fence: (a) a minimum of 100 feet (horizontal) from the MHT (mean high tide) line with 2 parallel rows of fence approximately 30 feet apart. The row alignment should be roughly parallel to the water line, yet as close as possible to a right angle to the prevailing winds. Figure DSF-1 shows a plan view of a conceptual erosion and sediment control system with the Dune Sand Fence configured to minimize adverse impacts to nesting endangered sea turtles.

Install posts a minimum of 3 feet deep and 10 feet apart. Do not concrete in place.

Use 4 galvanized wire ties to fasten the fence to the wood posts. Weave the fence between posts so that every other post will have fencing on the ocean side of posts.

If widening an old dune, the new fence should be set seaward 15 feet from its current base.

Construction Verification

Check materials for compliance with specifications.

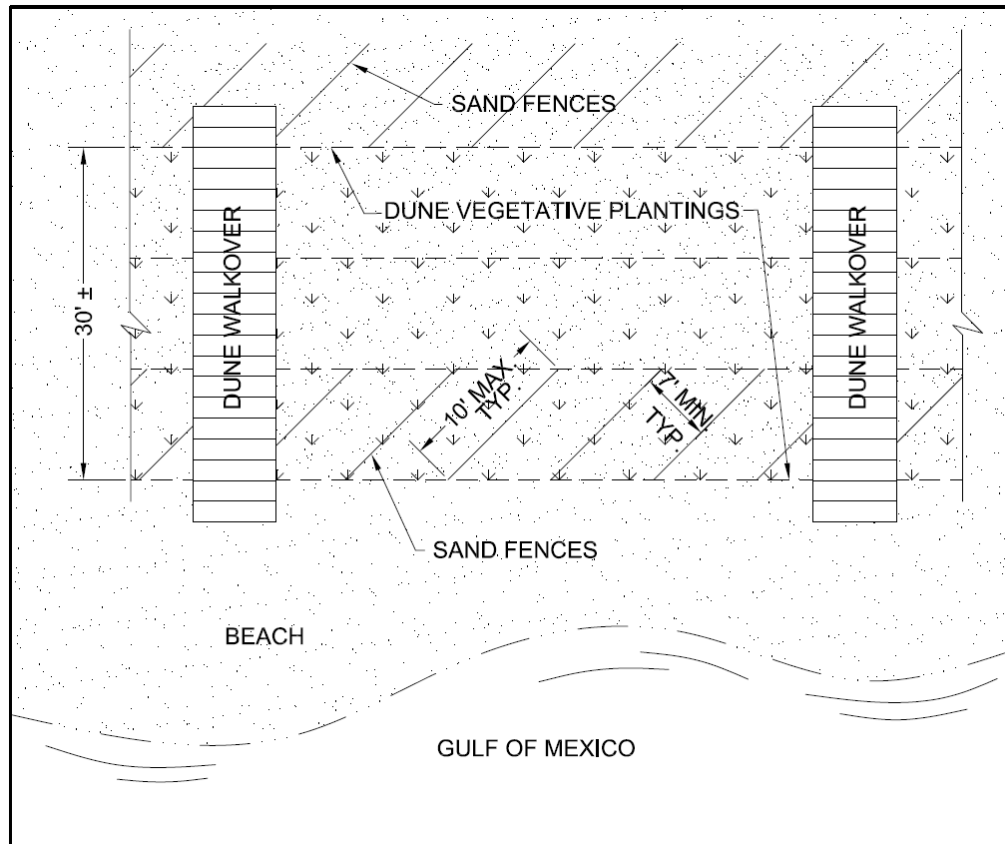

Figure DSF-1 Typical Dune Sand Fence

Common Problems

Consult with a qualified design professional if any of the following occur:

- Variations in topography on site indicate dune sand fence will not function as intended; changes in plan may be needed.
- Design specifications for materials cannot be met; substitutions may be required. Unapproved substitutions could lead to failure.

Maintenance

Inspect dune sand fences monthly and after each significant event with high winds and waves. Make required repairs immediately if fence is damaged by high wind or water.

As the fences fill with sand, additional sets of fence can be placed over those almost filled until the barrier dune has reached a protective height. To widen an old dune, fencing should be set seaward at a distance of 15 feet from its base.

Dune Vegetation Planting (DVP)



Photo courtesy of Alabama Department of Environmental Management

Practice Description

Dune vegetation planting is the establishment of perennial vegetation on dunes from seed or vegetative material. Perennial dune vegetation provides economical long-term erosion control and helps prevent sediment from leaving the site. This practice is used where vegetation is desired and appropriate to permanently stabilize the dune. Additional measures, such as crosswalks and barriers, are often needed to develop successful establishment of the vegetation.

Typical Components of the Practice

- Scheduling
- Site Preparation
- Fertilizing
- Planting
- Irrigating
- Construction Verification
- Maintenance

Installation

Prior to start of construction, details of the planting (species, rates, planting dates, etc.) should be specified by a qualified design professional. Plans and specifications should be referred to by field personnel throughout the installation process.

Scheduling

The schedule for work at the site should consider the recommended planting period and whenever practical the site work should accommodate planting during the recommended planting period.

Site Preparation

Construction of crosswalks and installation of sand fence, or other barriers, should be coordinated with the planting according to the design plan.

Seedbed preparation typical for non-dune plantings is not normally done.

Fertilizing

Fertilizer may be applied either before or after the planting, depending upon the specifications in the design plan. Apply fertilizer at rates specified in the design plan or as recommended by soil tests. In the absence of a design plan, use the following as a guide:

Evenly spread 13-13-13 at the rate of 200-300 lbs/ac (4.6 to 6.9 lbs /1000 ft²) either before or within 6 weeks after planting.

Note: Fertilizer can be blended to meet exact fertilizer recommendations and spread by a vendor. This may be more economical than spreading bagged fertilizer.

Planting

Plant the species specified in the plan at the rate and depth specified in the planting plan. In the absence of a plan consider the following guidelines.

Seed

Select adapted species from Table DVP-1.

Apply seed uniformly using a cyclone seeder or drop-type spreader.

When planting by methods other than a drill seeder, cover seed by raking, or dragging a chain, brush, or mat.

Table DVP-1 Commonly Used Plants for Dune Stabilization

Species	Plant Spacing	Planting Period	Method
Sea Oats <i>Uniola paniculata</i>	12 – 36"	March – June	Potted plants
Atlantic Coastal Panigrass <i>(Panicum amarum var-amarulum)</i>	12 – 36"	March – June	Seed or sprigs
Flageo Marshhay Cordgrass <i>(Spartina patens)</i>	12 – 24"	March – June	Sprigs
Sharpe Marshhay Cordgrass <i>(Spartina patens)</i>	12 – 24"	March – June	Sprigs
North PA Bitter Panicum <i>(Panicum amarum)</i>	24 – 36"	March – June	Potted plants or bare root plugs
South PA Bitter Panicum <i>(Panicum amarum)</i>	24 – 36"	March – June	Potted plants or bare root plugs

Vegetative Material

Select adapted species from Table DVP-1.

Plant the species specified in the plan at the rate and depth specified. In the absence of a plan consider the following guidelines.

Plant vegetative material 6” to 10” or deep enough to have adequate soil moisture at the time of planting.

Herbaceous plant spacing ranges from 1 to 3 feet but is typically 18” for 1” to 4” potted stock or bare root of the same diameter.

Irrigating

Apply irrigation as specified in the planting plan.

Construction Verification

Check materials and installation for compliance with specifications during installation of products.

Common Problems

Consult with a qualified design professional if the following occurs. Design specifications for plant species or planting dates cannot be met; substitutions may be required. Unapproved substitutions could lead to failure.

- Planting at the wrong time of the year results in an inadequate stand. Replant according to specifications of a qualified design professional (see recommendations under Maintenance)

Maintenance

Inspect plantings monthly for stand survival and vigor. Generally, a stand of vegetation cannot be determined to be fully established until vegetative cover has been maintained for 1 year from planting.

Replanting

Stand conditions, particularly the coverage, will determine the extent of remedial actions. A qualified design professional should be consulted to advise on remedial actions.

Fertilizing

Apply fertilizer at rates specified in the design plan or as recommended by soil tests. In the absence of a design plan, follow soil test recommendations or apply 13-13-13 at the rate of 400 lbs/acre annually (approximately 9 lbs/1000 ft²) during the growing season before September.

Fertilization is recommended until the plants spread to provide complete cover and after storms damage stands.

Dune Walkover (DW)



Photo courtesy of Alabama Department of Environmental Management Coastal Programs Office

Practice Description

A dune walkover is a measure consisting of elevated walks that are constructed across the dune system. It provides pedestrian access to the beach area and protects the dunes from erosion. It is applicable on sparsely vegetated dunes where pedestrian access adversely impacts the vegetation and on dunes with adequate vegetation where pedestrian access is planned and vegetation is needed to protect the dunes from erosion.

Typical Components of the Practice

- Scheduling
- Site Preparation
- Installation
- Erosion Control
- Safety
- Construction Verification
- Maintenance

Construction

Prior to start of construction, a dune walkover should be designed by a qualified design professional and necessary federal, state and local reviews and permits should be obtained. Plans and specifications should be referred to by field personnel throughout the construction process.

Scheduling

Attempt to construct dune walkover during the recommended planting periods for the associated dune vegetation plantings that are planned.

Site Preparation

Ensure that all necessary materials are on the site before any work begins.

Installation

Install the structure according to the design plan.

Erosion Control

Minimize the size of all disturbed areas and vegetate as soon as each phase of construction is complete. Establish vegetation on all renourished disturbed areas in accordance with the design plan.

If a planting plan is not available, refer to the Dune Vegetation Planting practice and Figure DW -1 for guidance.

Safety

Equipment used in construction should be free of leaks of fuel and hydraulic fluids.

Install fencing and post warning signs if trespassing is likely during construction.

Construction Verification

Check to determine that materials and construction meet plan specifications.

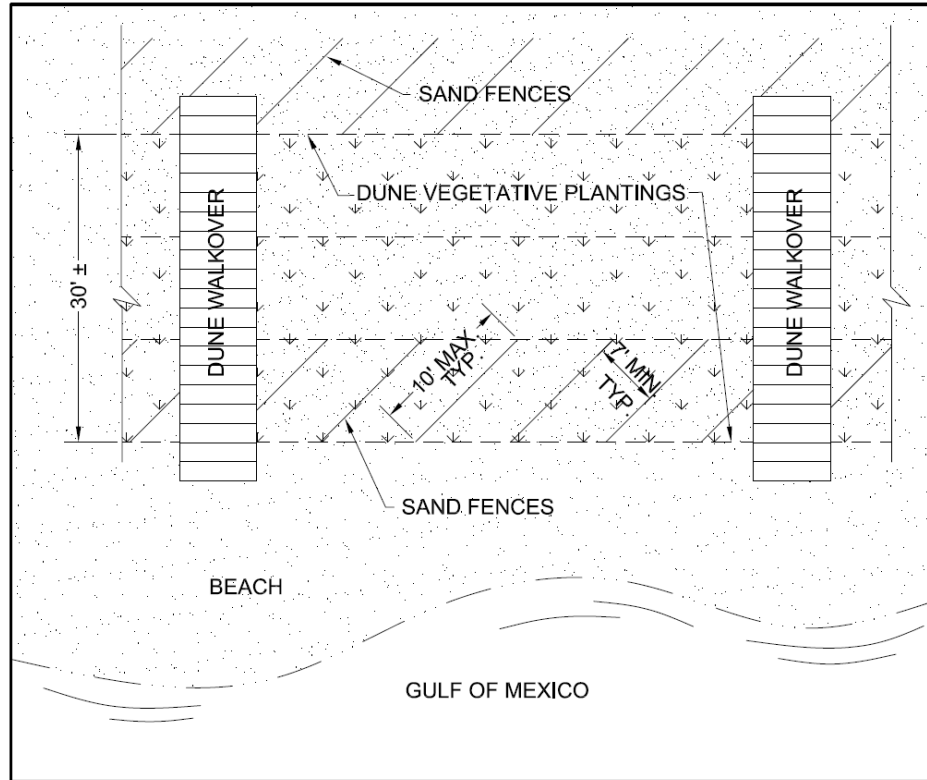

Figure DW-1 Typical Dune Walkover System

Common Problems

Consult with qualified design professional if any of the following occur:

- Variations in topography on site indicate dune walkover will not function as intended; changes in plan may be needed.
- Design specifications for materials cannot be met; substitution may be required. Unapproved substitutions could result in the crossing being washed out.

Maintenance

Inspect the dune walkover for damage to the structure after each major storm event.

Repair any damages to structural measures found during inspections. Replant materials that have been destroyed by high tides and major hurricanes.

This Page Intentionally Left Blank

Dust Control (DC)



Practice Description

Dust control includes a wide range of techniques that prevent or reduce movement of wind-borne soil particles (dust) during land disturbing activities. This practice applies to construction routes and other disturbed areas where on-site and off-site damage or hazards may occur if dust is not controlled.

Typical Components of the Practice

- Scheduling
- Erosion Control
- Other Potential Components
 - Sprinkling
 - Barriers
 - Spray-on Adhesives
 - Stone
 - Street Cleaning
- Installation Verification
- Maintenance

Construction

Dust control requirements should be designed by a qualified design professional and plans, and specifications should be made available to field personnel prior to start of construction. Whenever possible, leave undisturbed vegetated buffer areas between graded areas.

Scheduling

Schedule construction operations so that the smallest area is disturbed at any one time.

Erosion Control

Install surface stabilization measures (vegetative cover or mulch) immediately after completing the land grading.

Vegetative Cover

See Temporary or Permanent Seeding practice for guidance. Vegetation provides the most practical method of dust control for areas not subject to traffic.

Mulching

See Mulching practice for guidance on applying mulch and tackifiers or binders. Mulching is not recommended for areas with heavy traffic.

Other Potential Components

Sprinkling

Sprinkle the site with water until the surface is moist. This practice is effective for dust control on haul roads or other traffic routes, but constant repetition is required for effective control.

Barriers

Install board fences perpendicular to the prevailing winds at intervals (distance) of 15 times the barrier height.

Calcium Chloride

Apply with a mechanical spreader at a rate that keeps the surface moist.

Consult with a qualified design professional to determine if a permit is required.

Spray-on Adhesives

Spray adhesives according to the design plan.

Consult with a qualified design professional if spray-on adhesives are specified. A permit may be needed.

In the absence of a detailed plan, use manufacturers’ recommendations. Table DC-1 presents examples of spray-on adhesives that have been used successfully for dust control.

Table DC-1 Application Rates for Spray-on Adhesives Used in Dust Control

Adhesive	Water Dilution (adhesive : water)	Type of Nozzle	Application Rate (gallons/acre)
Anionic Asphalt Emulsion	7:1	Coarse	1200
Latex Emulsion	12.5:1	Fine	235
Resin in Water	4:1	Fine	300
Acrylic Emulsion (Non-traffic)	7:1	Coarse	450
Non-Acrylic Emulsion (Traffic)	3.5:1	Coarse	350

Source: Virginia Erosion and Sediment Control Handbook, 1993

Consult with a qualified design professional if spray-on adhesives are specified. A permit may be needed.

Stone

Stone should be placed to the width and thickness specified in the design.

Street Cleaning

Use a street sweeper to remove the source materials.

Construction Verification

Check installation of product(s) to verify use of proper product and quantity.

Common Problems

Drought conditions result in dry soils and increase in dust problems—use greater precautions during these periods.

Maintenance

Check construction site during vehicular traffic or windy conditions to see if measures are working adequately. Maintain dust control measures continuously throughout dry weather periods, until all disturbed areas have been stabilized.

Erosion Control Blanket (ECB)



Photo courtesy of Sunshine Supplies, Inc.

Practice Description

Erosion Control Blanket is a practice using a rolled erosion control product (RECP) composed of processed natural or polymer fibers (straw, jute, wood paper or cotton, plastic, nylon) mechanically, structurally, or chemically bound together to form a continuous matrix used to provide erosion control and most often facilitates vegetation establishment. This practice is best utilized on slopes and channels where the erosion hazard is high, and plant growth is likely to be too slow to provide adequate protective cover. Erosion control blankets are typically used as an alternative to mulching but can also be used to provide structural erosion protection.

Typical Components of the Practice

- Site Preparation
- Erosion Control Planting
- Blanket Installation
- Construction Verification
- Maintenance

Erosion Control Blanket Information

Prior to the start of construction, the application of erosion control blankets should be designed by a qualified design professional and plans and specifications should be available to field personnel.

Numerous products designed to control erosion are available. Product installation procedures for manufactured erosion control blanket products should always be available from the manufacturer. Table ECB-1 lists some of the more common products available.

Table ECB-1 Types of Erosion Control Blankets

Type of Erosion Control	Main Use	Comments
Netting	Synthetic or natural fiber mesh installed over disturbed area to hold organic mulch and/or seed in place.	Provides minimal structural erosion resistance. Mulch applied using standard procedures.
Biodegradable Erosion Control Blanket	Natural fiber blanket held together by netting to provide temporary erosion protection on slopes up to 1:1; and channels with permissible shear stress up to 4 lbs./ft.	Provides 1- to 5-year protection from erosion. Metal staples used as anchors.
Permanent Erosion Control Blanket	Synthetic blanket material which provides permanent erosion control on slopes up to 1:1; channels with increased water flow velocities and increased shear stress.	Provides minimal protection from wave action around ponds and lakes. Permanent erosion control blankets extend the limits of vegetation. Metal staples used as anchors.
Turf Reinforcement Mat	3-dimensional permanent synthetic mat that provides a matrix to greatly reinforce the root system of the desired vegetation for permanent erosion protection in high flow channels and on critical slopes.	Provides a substantial increase in erosion resistance. May provide erosion protection equivalent to stone or concrete liners.

The field inspector should verify that installation is in accordance with the plans and specifications.

Site Preparation

Grade the site in accordance with the approved design to a smooth and uniform surface, free of debris.

Add and incorporate topsoil where needed.

Make sure seedbed is firm yet friable.

Erosion Control Planting

Spread and incorporate lime and fertilizer as described in the design plan.

Spread seed and incorporate as described in the planting specifications.

Blanket Installation

Erosion control blanket products should be installed in accordance with the manufacturer's recommendations and specifications, including check slots and stapling materials.

Anchor product so that a continuous, firm contact (no tenting) with the soil surface/seed bed is maintained. This is best accomplished on slopes by working from the bottom to the top.

Construction Verification

Check finished grade, dimensions and staple spacing of erosion control blankets. Check materials for compliance with specifications.

Common Problems

Consult with a qualified design professional if any of the following occur:

- Movement of the blanket or erosion under the blanket is observed.
- Poor contact between the soil and the erosion control blanket results in surface water flowing under rather than over the blanket, causing erosion; retrench or re-anchor to direct water over blanket.
- Blanket inadequately or improperly stapled results in tenting, blanket movement or displacement; reinstall and ensure blanket is properly anchored.
- Unstable slope results in blanket or slope failure; determine cause of slope failure, stabilize slope and reinstall blanket.
- Variations in topography on site indicate erosion control blanket will not function as intended; changes in plan may be needed, or a blanket with a shorter or longer life may be needed.
- Design specifications for seed variety, seeding dates or erosion control materials cannot be met; substitution may be required. Unapproved substitutions could result in failure to establish vegetation or breach of contract.

Maintenance

Inspect after storm events until vegetation is established for erosion or undermining beneath the blankets. If any area shows erosion, pull back that portion of the blanket, add tamped soil and reseed; then resecure the blankets.

If blankets should become dislocated or damaged, repair or replace and resecure immediately.

Groundskeeping (GK)



Practice Description

Groundskeeping or “good housekeeping” describes the various activities and measures, in addition to the specific practices used for erosion and sediment control that are essential during construction for the protection of environmental quality. Groundskeeping is applicable at all construction sites.

Typical Components of the Practice

Prior to the start of construction, Groundskeeping activities and measures should be identified by a qualified design professional and included in the construction and pollution prevention plan. The essential components of Groundskeeping should be provided to the prime contractor for a project. Groundskeeping activities and measures essential at construction sites vary based on the complexity of the site and the project. Groundskeeping typically includes the following activities and measures:

- Inspections During Construction/Installation of Erosion and Sediment Control and Stormwater Measures (BMPS)
- Spill Prevention and Material Management
- Spill Controls

- Other Potential Activities and Measures (examples: removal of contaminated soils, management of hazardous products, protection of air quality, etc.)

Details about Components

Inspections of BMPs

Inspections should be made regularly and timely to ensure that erosion and sediment control and stormwater management practices are performing as planned and whether or not maintenance is needed. In addition, inspections and reports should meet local and state requirements.

Spill Prevention and Material Management

Alabama Department Environmental Management (ADEM) regulations require that an operator/owner implement a Spill Prevention Control and Counter Measures (SPCC) Plan for all temporary and permanent onsite fuel or chemical storage tanks or facilities to address the safe storage, handling and cleanup of petroleum products and other chemicals.

All vehicles kept on the site need to be monitored for leaks and receive regular preventive maintenance to reduce the chance of leakage.

If petroleum products are stored on site, a secondary containment facility will be required if the cumulative storage capacity of all tanks, greater than 55 gallons, at the site exceeds 1,320 gallons. The secondary containment facility must be designed by a qualified design professional.

Petroleum products should be stored in labeled tightly sealed containers.

Any asphalt substances used on-site should be applied according to the manufacturer's recommendations.

Locate petroleum-based activities as far away as possible from waters of the State and stormwater inlets or conveyances so that stormwater coming into contact with these activities cannot reach water of the State. No fueling, servicing, maintenance, or repair of equipment or machinery should be done within 50 feet of a stream, or within 100 feet of a stream classified for public water supply (PWS) or Outstanding Alabama Water (OAW), or designated as an Outstanding National Resource Water (ONRW) or a sinkhole.

Only designated entrances should be used for construction access to the site. Mud tracked from the site onto streets and roads should be cleaned on a daily basis if needed. Only use “dry” methods like sweeping to remove mud from streets. DO NOT use water to flush mud from the street.

Concrete trucks should be allowed to wash only in locations where discharge is appropriately contained and meets any applicable regulatory requirements. All

the concrete truck washout or waste discharge on-site must be contained to be properly removed, recycled, or disposed of later. Containment can be in the form of metal, vinyl, plastic, or poly lined containers or pits, filter bags, or manufactured products. It is best to use proper signage at the concrete washout location. It is not permissible to discharge concrete wash directly to streams or storm drains. Concrete wash can contain sediment, as well as, alkalinity and chemical additives that could be harmful to fish, stream bottom macroinvertebrates and wildlife.

No fuels, oils, lubricants, solvents, or other hazardous materials can be disposed of on the site. All hazardous material must be properly disposed of in accordance with state law.

Waste containers should be located as far away as possible from waters of the State and stormwater inlets or conveyances so that stormwater coming into contact with these activities cannot reach water of the State. The General Contractor is responsible for disposing of all solid waste from the site in accordance with State law. Dumpsters or other collection facilities must be provided as needed. Solid waste may not be buried on the site.

Portable toilets should be located so that accidental spills will not discharge into a storm sewer or concentrated flow area.

Water for pressure testing sanitary sewers, flushing water lines, etc., may be discharged only in approved areas and to prevent discharging to surface waters. Discharge of hydrostatic test water may require additional permitting, particularly if chlorinated public water is used.

Spill Controls

The operator/owner is expected to maintain on-site or have readily available sufficient oil & grease absorbing material and flotation booms to contain and clean-up fuel or chemical spills and leaks.

Equipment and materials include, but are not limited to brooms, dust pans, mops, rags, gloves, goggles, absorbent clay, sand, sawdust, and plastic and metal trash containers specifically for this purpose.

Spills of toxic or hazardous material must be reported immediately. The operator/owner is required to immediately notify ADEM after becoming aware of a significant spill/leak or visible oil sheen in the vicinity of the construction activity. In the event of a spill with the potential to impact groundwater or other waters of the State, the operator/owner is expected to immediately call the National Response Center (NRC) at 1-800-424-8802 and the Alabama Emergency Management Agency (AEMA) at 1-800-843-0699. The caller should be prepared to report the name, address and telephone number of person reporting spill, the exact location of the spill, the company name and location, the material spilled, the estimated quantity, the source of spill, the cause of the spill, the nearest downstream water with the potential to receive the spill, and the actions taken for containment and cleanup.

All spills need to be cleaned up immediately after discovery and properly containerized for proper disposal. Refer to Material Safety Data Sheets for safe handling procedures. Burial is not acceptable.

The spill area must be kept well ventilated and personnel need to wear appropriate protective clothing to prevent injury from contact with a hazardous substance.

The spill prevention plan needs to be adjusted to include measures to prevent any spill from being repeated, and the plan needs to show how to clean up the spill if another one does occur.

Removal of Contaminated Soils and Underground Storage Tanks

Site assessment and removal of contaminated soils and underground storage tanks should be done following a site assessment based on procedures provided by the Alabama Department of Environmental Management.

Management of Hazardous Products

Products must be kept in original containers unless they are not resealable. If a product is transferred to a new container, it must be properly marked and labeled.

Original labels and Material Safety Data Sheets should be retained until the related product is no longer on the site.

If surplus product must be disposed of, disposal must be done in accordance with state (Alabama Department of Environmental Management regulations).

Protection of Air Quality

Smoke

Burning on the site may require a permit from the Alabama Forestry Commission. County and city ordinances may also apply. Starting disposal fires with diesel fuel, petroleum products, or old tires is not a recommended practice. Burn pits with fans to generate hot disposal fires decreases the fire time and minimizes smoke. Burning may be prohibited by State “burn bans” to reduce potential for ground-level ozone.

Dust

Dust should be controlled if it will create a problem either on or off of the site. If measures are not included in the site design plan see the practice Dust Control for potential measures to use to eliminate or minimize dust.

Other Good Groundskeeping Practices

The following measures may be needed:

- All materials stored on-site should be stored in a neat, orderly manner in their appropriate containers and, if possible, under a roof or other enclosure.
- Products should be kept tightly sealed in their original containers with the original manufacturer's label.
- Whenever possible, all of a product should be used up before disposing of the container.
- Manufacturer's recommendations for proper use and disposal must be followed. See Material Safety Data Sheets for product of concern.

The site superintendent or a designated employee should inspect daily to ensure proper usage, storage, and disposal of material.

This Page Intentionally Left Blank

Mulching (MU)



Practice Description

Mulching is the application of plant residues such as straw or other suitable materials to the soil surface to minimize erosion. Mulching is used to support permanent and temporary seeding and, also, to provide short-term cover without seeding.

Typical Components of the Practice

- Site Preparation
- Application of Material
- Installation Verification
- Maintenance

Installation

Mulching should be designed by a qualified design professional and plans and specifications should be made available to field personnel prior to start of construction.

Site Preparation

Divert runoff water from areas above the site that will be mulched.

Remove stumps, roots and other debris from the construction area.

Grade area as needed to permit the use of equipment for seeding, mulching and maintenance. Shape area so that it is relatively smooth.

If the area will be seeded, follow seeding specifications in the design plan and apply mulch immediately after seeding.

Application of Material

Spread straw mulch, preferably cereal grain, uniformly over the area with a power blower, hydroseeder or by hand. Mulch should be uniformly spread and not clumped in piles. In a seeded area, about 25% of the ground surface should be visible after mulching. It is important when mulching a seeded area that an excessive quantity of straw is not applied – too much mulch will retard or reduce the future stand. When mulch is used for erosion control without seeding, 100% of the soil surface should be covered.

Hydraulic Erosion Control Products (HECPs) as defined by the Erosion Control Technology Council (ECTC) are also used for mulch and should be applied with the appropriate equipment and at the recommended or specified rates.

Apply mulches at the rates shown in the plan or in Table MU-1 if there is not a plan.

Anchor straw or wood cellulose mulch by one of the following methods:

- Crimp with a mulch anchoring tool, as near on the contour as practical, to punch the straw into the soil.
- Tack with a liquid tackifier designed to hold mulch in place. Use suitable spray equipment and follow manufacturer's recommendations.
- In more erosive areas, cover with netting, using a degradable natural or synthetic mesh. The netting should be anchored according to manufacturer's specifications (see Erosion Control Blanket practice).
- On steep slopes and other areas needing a higher degree of protection, use heavy natural nets without additional mulch, synthetic netting with additional mulch or erosion control mats/blankets. These areas include grassed waterways, swales and diversion channels.
- Install netting and mats/blankets according to manufacturer's specifications making sure materials are properly anchored (see Erosion Control Blanket). Verify wildlife friendly netting when specified.

Table MU-1 Mulching Materials and Application Rates

Material	Rate Per Acre and (Per 1000 ft. ²)	Notes
Straw (with Seed)	1 ½ - 2 tons (70 lbs - 90 lbs)	Spread by hand or machine; anchor when subject to blowing.
Straw Alone (no seed)	2 ½ - 3 tons (115 lbs - 160 lbs)	Spread by hand or machine; anchor when subject to blowing.
Wood Chips	5-6 tons (225 lbs - 270 lbs)	Treat with 12 lbs. nitrogen/ton.
Bark	35 cubic yards (0.8 cubic yard)	Can apply with mulch blower.
Pine Straw	1-2 tons (45 lbs - 90 lbs)	Spread by hand or machine; will not blow like straw.
Peanut Hulls	10-20 tons (450 lbs - 900 lbs)	Will wash off slopes. Treat with 12 lbs. nitrogen/ton.
HECPs	0.75 – 2.25 tons (35 lbs – 103 lbs)	Refer to ECTC or Manufacturer's Specifications.

Installation Verification

Check materials and installation for compliance with specifications.

Common Problems

Consult with qualified design professional if either of the following occurs:

- Variations in topography on site indicate the mulching materials will not function as intended; changes in plan may be needed.
- Design specifications for mulching materials or seeding requirements cannot be met; substitution may be required. Unapproved substitutions could result in erosion or seeding failure.

Problems that require remedial actions:

- Erosion, washout, and poor plant establishment; repair eroded surface, reseed, re-mulch and anchor mulch.
- Mulch is lost to wind or stormwater runoff; reapply mulch and anchor appropriately by crimping, netting, or tacking.

Maintenance

Inspect all mulched areas periodically and after rainstorms for erosion and damage to the mulch. Repair promptly and restore to original condition. Continue inspections until vegetation is well established. Keep mower height high if netting is used to prevent netting from wrapping around mower blades or shaft.

Permanent Seeding (PS)



Practice Description

Permanent seeding is the establishment of perennial vegetation from seed. This practice is used when vegetation is desired and appropriate to permanently stabilize the soil.

Typical Components of the Practice

- Scheduling
- Seedbed Preparation
- Applying Soil Amendments (lime and fertilizer)
- Planting
- Mulching or Installation of Erosion Control Blanket
- Installation Verification
- Maintenance

Installation

Prior to start of construction, plant materials, seeding rates and planting dates should be specified by a qualified design professional. Plans and specifications should be referred to by field personnel throughout the installation process.

Permanent seeding should be made during the specified planting period whenever possible. When sites are only available for planting outside of the recommended planting period, either an out-of-season permanent seeding, a temporary seeding, mulching or chemical stabilization should be applied. If lime and fertilizer application rates are not specified, take soil samples during final grading from the top 6" in each area to be seeded. Submit samples to a soil testing laboratory for lime and fertilizer recommendations.

Scheduling

The schedule for work at the site should consider the recommended planting period and whenever practical the site work should accommodate seeding during the recommended planting period.

Seedbed Preparation

Grade and loosen the soil to a smooth firm surface to enhance rooting of seedlings and reduce rill erosion. Break up large clods and loosen compacted, hard or crusted soil surfaces with a disk, ripper, chisel, harrow or other tillage equipment. Avoid preparing the seedbed under excessively wet conditions to minimize compaction. Operate the equipment on the contour.

For either broadcast seeding or drill seeding, the tillage, as a minimum, should adequately loosen the soil to a depth of at least 6", alleviate compaction, and smooth and firm the soil for the proper placement of seed.

For no-till drilling, the soil surface should not be loosened unless the site has surface compaction and if compaction exists, special care with soil loosening will be needed to retain the desired residue on the soil surface.

Incorporate lime and fertilizer to a depth of at least 6" with a disk or rotary tiller on slopes of up to 3:1. On steeper slopes, lime and fertilizer may be applied to the surface without incorporation. Lime and fertilizer may be applied through hydroseeding equipment; however, fertilizer should not be added to the seed mixture during hydroseeding. Liming materials such as liquid lime may be added with the seed mixture.

Liming

Follow the design plan or soil test recommendation. If a plan or soil test is not available, use 2 tons/acre of ground agricultural lime on clayey soils (approximately 90 lbs/acre) and 1 ton/acre on sandy soils (approximately 45 lbs/acre). Exception to situation without a design or a soil test: If the cover is tall fescue and clover, use 2 tons of agricultural lime (approximately 135 lbs/1000 ft²) on both clayey and sandy soils.

Spread the specified amount of lime and incorporate into the top 6" of soil after applying fertilizer.

Fertilizing

Apply a complete fertilizer at rates specified in the design plan or as recommended by soil tests. In the absence of soil tests, use the following as a guide:

Grass Alone

Use 8-24-24 or equivalent – apply 400 lbs/acre (approximately 9 lbs/1000 ft²) starting. When vegetation has emerged to a stand and is growing, 30 lbs/acre (approximately 0.8 lbs/10000 ft²) of additional nitrogen fertilizer should be applied.

Grass-Legume Mixture

Use 5-10-10 or equivalent – apply 800 - 1200 lbs/acre (approximately 18 – 27 lbs/1000 ft²).

Legume Alone

Use 0-20-20 or equivalent – apply 400 - 600 lbs/acre (approximately 9 – 14 lbs/1000 ft²) at planting.

Note: Fertilizer can be blended to meet exact fertilizer recommendations. Take soil test recommendations to local fertilizer dealer for bulk fertilizer blends. This may be more economical than bagged fertilizer.

Planting

Plant the species specified in the plan at the rate and depth specified. In the absence of plans and specifications, plant species and seeding rates may be selected by qualified persons using Figure PS-1 and Table PS-1.

Apply seed uniformly using a cyclone seeder, drop-type spreader, drill, cultipacker seeder or hydroseeder.

When using a drill seeder, plant grasses and legumes ¼” to ½” deep. Calibrate equipment in the field.

When planting by methods other than a drill seeder, cover seed by raking, or dragging a chain, brush, or mat. Then firm the soil lightly with a roller. Seed can also be covered with hydro-mulched wood fiber and tackifier. Legumes require inoculation with nitrogen-fixing bacteria to ensure good growth. Purchase inoculum specific for the seed and mix with seed prior to planting.

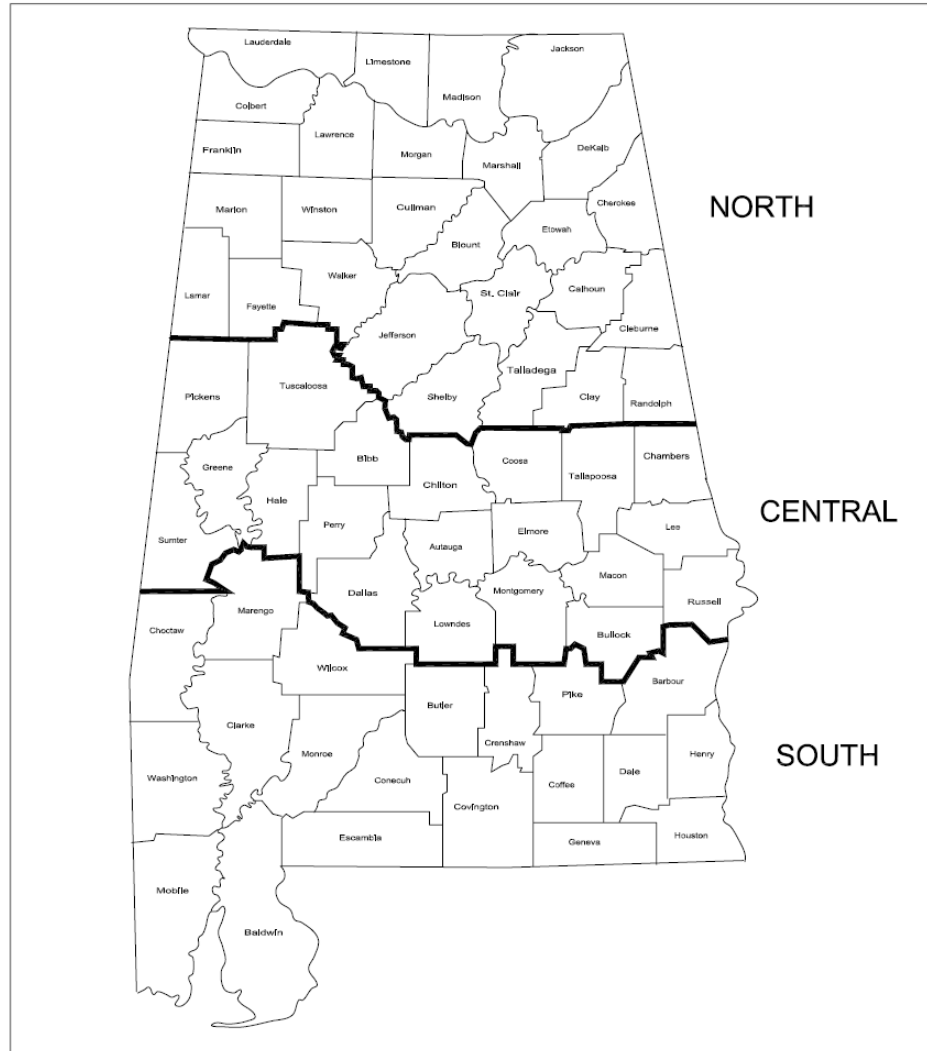

Figure PS-1 Geographical Areas for Species Adaptation

Note: Site conditions related to soils and aspect in counties adjacent to or close to county boundaries may justify adjustments in adaptable areas by qualified design professionals.

Mulching

Mulching is extremely important for successful seeding. Whether the mulching material is straw or a hydraulic erosion control product (HECP, also referred to as hydromulch), the material needs to be applied properly. Uniformly spread organic mulches by hand or with a mulch blower at a rate which provides about 75% ground cover. Spread HECPs utilizing appropriate equipment and at rates as specified in the plan or by the manufacturer. Caution, an over-application of wheat straw will reduce stand success – do not over-apply wheat straw when mulching a seeding! (See Mulching practice for more details).

Table PS-1 Commonly used Plants for Permanent Cover with Seeding Rates and Dates¹

Species	Seeding Rates/Ac PLS ²	North	Central	South
		Seeding Dates		
Bahiagrass, Pensacola	40 lbs	--	Mar 1-Jul y 1	Feb 1-Nov 1
Bermudagrass, Common	10 lbs	Apr 1-July 1	Mar 15-July 15	Mar 1-July 15
Bahiagrass, Pensacola Bermudagrass, Common	30 lbs 5 lbs	--	Mar 1-July 1	Mar 1-July 15
Bermudagrass, Hybrid (Lawn Types)	Solid Sod	Anytime	Anytime	Anytime
Bermudagrass, Hybrid (Lawn Types)	Sprigs 1/sq ft	Mar 1-Aug 1	Mar 1-Aug 1	Feb 15 - Sep 1
Fescue, Tall	40-50 lbs	Sep 1-Nov 1	Sep 1-Nov 1	--
Sericea	40-60 lbs	Mar 15-July 15	Mar 1-July 15	Feb 15 -July 15
Sericea & Common Bermudagrass	40 lbs 10 lbs	Mar 15 -July 15	Mar 1-July 15	Feb 15-July 15
Switchgrass, Alamo	4 lbs	Apr 1-Jun 15	Mar 15-Jun 15	Mar 15-June 15

1 DO NOT USE Seeding Rates as part of a mixture unless shown as a mixture in this table.

2 PLS means Pure Live Seed and is used to adjust seeding rates. For example, to plant 10 lbs PLS of a species with germination of 80% and purity of 90%, PLS= 0.8 X 0.9 = 72%. 10lbs PLS = 10/0.72 = 13.9 lbs of the species to be planted.

Hydroseeding

Surface roughening is particularly important when hydroseeding, as roughened slope will provide some natural coverage for lime, fertilizer, and seed. The surface should not be compacted or smooth. Smooth seedbed preparation is not necessary for hydroseeding operations; large clods, stones, and irregularities provide cavities in which seeds can lodge.

Mix seed, inoculant if required, and a seed carrier with water and apply as a slurry uniformly over the area to be treated. The seed carrier should be a cellulose fiber, natural wood fiber or cane fiber mulch material which is dyed an appropriate color to facilitate uniform application of seed. If adding a legume, and it does not have an inoculant included in the coating, include the correct legume inoculant at 4 times the recommended rate when adding seed to the hydroseeder slurry. The mixture should be applied within one hour after mixing to reduce damage to seed.

Fertilizer should not be mixed with the seed-inoculant mixture because fertilizer salts may damage seed and reduce germination and seedling vigor.

Fertilizer may be applied with a hydroseeder as a separate operation after seedlings are established.

Agricultural lime is usually applied as a separate operation and spread in dry form. It is not normally applied with a hydraulic seeder because it is abrasive and, also, may clog the system. On the other hand, liquid lime is applied with a hydraulic seeder but because of cost is used primarily to provide quick action for benefit of plants during their seedling stage with the bulk of liming needs to be provided by agricultural lime. Dry lime may be applied with the fertilizer mixture.

Installation Verification

Check materials and installation for compliance with specifications during installation of products.

Common Problems

Consult with a qualified design professional if the following occurs:

- Design specifications for seed variety, seeding dates or mulching cannot be met; substitutions may be required. Unapproved substitutions could lead to failure.
- Seeding at the wrong time of the year results in an inadequate stand. Reseed according to specifications of a qualified design professional (see recommendations under Maintenance)
- Inadequate mulching results in an inadequate stand, bare spots, or eroded areas - prepare seedbed, reseed, cover seed evenly and tack or tie down mulch, especially on slopes, ridges and in channels (see recommendations under Maintenance).

Maintenance

Generally, a stand of vegetation cannot be determined to be fully established until vegetative cover has been maintained for 1 year from planting.

Reseeding

Inspect seedlings monthly for stand survival and vigor. Also, inspect the site for erosion.

If stand is inadequate identify the cause of failure (choice of plant materials, lime and fertilizer quantities, poor seedbed preparation or weather) and take corrective action. If vegetation fails to grow, have the soil tested to determine whether pH is in the correct range or nutrient deficiency is a problem.

Stand conditions, particularly the coverage, will determine the extent of remedial actions such as seedbed preparation and reseeded. A qualified design professional should be consulted to advise on remedial actions. Consider drill seeding where possible.

Eroded areas should be addressed appropriately by filling and/or smoothing, and reapplication of lime, fertilizer, seed, and mulch.

Fertilizing

Satisfactory establishment may require fertilizing the stand in the second growing season. Follow soil test recommendations or the specifications provided to establish and maintain the planting. After the second year, fertilizing is often needed annually or periodically to maintain a healthy stand and cover sufficient for erosion control.

Mowing

Mow vegetation on structural practices such as embankments and grass-lined channels to prevent woody plants from invading.

Other areas should be mowed to compliment the use of the site.

Certain species can be weakened by mowing regimes that significantly reduce their food reserves stored for the next growing season: fescue should not be mowed close during the summer; sericea should not be mowed close in late summer.

Bermudagrass and bahiagrass are tolerant of most mowing regimes and can be mowed often and close, if so desired, during their growing season.

This Page Intentionally Left Blank

Preservation of Vegetation (PV)



Practice Description

Preservation of vegetation is the avoidance of an area during land disturbing and construction activity to prevent mechanical and other injury to desirable plants in the planned landscape. The practice provides erosion and sediment control and is applicable where vegetative cover is desired and the existing plant community is compatible with the planned landscape.

Typical Components of the Practice

- Mark Plant Area for Retention
- Plant Protection
- Treating Damaged Plants
- Practice Verification
- Maintenance

Installation

Preservation requirements should be designed by a qualified design professional and plans should be made available to field personnel prior to start of construction

Mark Plant Area for Retention

Clearly indicate the areas to be avoided by marking with tape (flagging), barricade netting or other appropriate means.

Plant Protection

Protect plants that are identified for preservation from compaction by equipment, cutting and filling operations, trenching, and tunneling.

Treating Damaged Plants

Treat damaged trees and shrubs as soon after damage as practical. Treatment may include shaping a wound for proper healing, pruning of jagged roots, pruning of damaged limbs and fertilization to enhance growth.

Practice Verification

Check to determine that specifications are met as the areas are identified for retention, as the plants are protected during construction and that damaged plants are treated or replaced.

Common Problems

Consult with a qualified design professional if any of the following occur:

- Soil compaction appears to be retarding plant growth or affecting plant health.
- Damage to plants appears to be severe and life threatening.
- Plants appear of poor quality and are undesirable for retention.

Problems during construction that require remedial actions:

- Erosion – eroded areas should be vegetated to grass or a suitable ground cover.
- Severely damaged trees, shrubs or vines should be replaced.

Maintenance

Enhance and maintain plant growth and health according to the maintenance plan. This may involve applying fertilizer, spreading mulch and pruning trees and shrubs.

_____ Installation and Maintenance of Best Management Practices

Replace dead plants as needed to maintain desired landscape cover. Additional information about plantings is found in the following practices: Permanent Seeding: Shrub, Vine and Groundcover Planting: and Tree Planting on Disturbed Areas.

This Page Intentionally Left Blank

Retaining Wall (RW)



Practice Description

A retaining wall is a constructed wall used to eliminate steep slopes between areas that have abrupt changes in grade. This practice is used to replace cut or fill slopes in confined areas or where a wall is necessary to achieve stable slopes. A retaining wall can be constructed of reinforced concrete, treated timbers, gabions, reinforced earth (a system of face panels and buried reinforcement strips), or other manufactured products such as interlocking concrete blocks.

Typical Components of the Practice

- Site Preparation
- Grading
- Foundation Preparation
- Installation of Wall
- Drain Installation
- Backfill Installation
- Erosion Control
- Safety
- Construction Verification
- Maintenance

Construction

Prior to the start of construction, a qualified design professional should design and specify the construction requirements for retaining walls. Plans and specifications should be available to field personnel.

Site Preparation

At least 3 days prior to construction, contact the Alabama Line Location Center (dial 811) to identify, locate and mark all underground utilities within the project area.

Clear installation area of debris and obstacles, such as tree and stumps, that might hinder grading and installation of the wall.

Grading

Grade existing embankments according to the design plan to provide a stable slope until construction of the retaining wall is complete.

Grade the top of the embankments according to the design plan to direct stormwater runoff around the area where retaining walls are being constructed.

Foundation Preparation

Prepare the foundation for the retaining wall in accordance with the design plans.

Installation of Wall

Concrete Wall Installation

The placement of reinforcing steel, the construction of forms, concrete batching, mixing, placement, curing, and finishing should be in accordance with the project specifications and the American Concrete Institute (ACI) standards. The concrete mix quantities, air entrainment, slump, temperature, and compressive strength should be in accordance with the plans for the job.

Compressive strength of the concrete should be verified by laboratory tests on representative cylinders made during concrete placement.

Drains and weep holes should be installed as shown on the design plans.

Modular Block Wall Installation

Prepare a leveling pad of compacted, crushed rock (typically 6" thick and 18" wide). Place the first row of modular blocks on the leveling pad (not a footing, as the geosynthetic reinforcement will bear the weight of the block and the backfill). Install additional modular blocks and geosynthetic reinforcement (geogrid or geotextile) according to design plans.

Timber Wall Installation

Timbers should be new pressure-treated (usually 0.6 pcf for ground contact) members having a design life consistent with that of the project and free of splits and deep cracks.

Proper tiebacks are essential to the stability of timber retaining walls. Install tiebacks according to design plans.

Manufactured Products Installation

Specifications for manufactured products should be provided by the manufacturer or in the design plan. Inspect all such materials for damage prior to installation.

Drain Installation

Install drains as specified in the design plans.

Backfill Installation

Backfill for all wall types should be placed carefully in layers not exceeding 8" (loose) and compacted with hand-operated tampers. The degree of compaction should be provided as specified in the design plans. Before compacting, the soil should be moistened or dried as necessary to obtain the optimum moisture content specified. Backfill should not be placed on surfaces that are muddy, frozen or contain frost or ice.

Backfill for retaining walls built of manufactured products such as reinforced earth or interlocking concrete blocks should be placed according to manufacturer's recommendations. Tiebacks or geosynthetic reinforcements should be placed as specified in the design plans.

Nonwoven geotextile fabric should be used behind timber or modular block walls to help keep soil in place.

Erosion Control

Stabilize all bare areas according to the vegetation plan.

Safety

Steep slopes are subject to collapse and can be a safety hazard to persons in the area. No person should work adjacent to steep slopes without shoring protection or properly sloping the embankment.

Construction Verification

Check finished retaining wall for conformance with design plans and specifications.

Check for cracks or movement of the retaining wall.

Common Problems

Consult with a qualified design professional if any of the following occur:

- Variations in topography on site indicate retaining wall will not function as intended.
- Seepage is encountered during construction. It may be necessary to install drains.
- Poor foundation soils are encountered under the proposed wall location.
- Design specifications for concrete, timbers, backfill or other materials cannot be met; substitutions may be required. Unapproved substitutions could lead to failure.
- High soil and water pressures result in structural failure of the wall consult qualified design professional and rebuild according to revised plan and specifications.

Maintenance

Inspect retaining walls periodically and after heavy rains for cracks, undercutting of the foundation, piping erosion, wetness, or movement.

Repair problems determined during inspections. Repair cracks according to manufacturer's recommendations.

Shrub, Vine and Groundcover Planting (SVG)



Practice Description

Shrub, vine and groundcover planting is establishing shrubs, vines or groundcover to stabilize landscapes where establishing grass is difficult and mowing is not feasible. The practice is especially suited for steep slopes where aesthetics are important. Incidental benefits include providing food and shelter for wildlife, windbreaks or screens and improved aesthetics.

Typical Components of the Practice

- Site Preparation
- Soil Amendments (lime and fertilizer)
- Planting
- Mulching
- Watering
- Installation Verification
- Maintenance

Installation

Shrub, vine and groundcover planting requirements should be designed by a qualified design professional and plans, and specifications should be made available to field personnel prior to start of planting.

Site Preparation

Sites should be prepared in strips along the contour or by individual spots. Site preparation may include contour tilling or the digging of individual holes. Site preparation will vary according to type of plant.

On steep slopes, till the soil in contour rows or dig single holes for each plant. Blend the needed lime, fertilizer, and organic material with the soil removed from each hole or furrow. Mix fertilizer thoroughly with the soil before planting and use it sparingly to avoid burning roots. To eliminate harmful competition from weeds, an appropriate pre-emergent herbicide may be useful if weeding is not practical.

Soil Amendments (lime and fertilizer)

Plantings of shrubs, vines and groundcovers may need applications of fertilizer and lime. Amendments should be applied according to the site plan or by soil test recommendations. In the absence of a plan or soil test recommendations, apply agricultural limestone into the top 6" of soil at the rate of 50 lbs. of agricultural limestone and 25 lbs. of 8-8-8 per 1000 ft² for group plantings of groundcovers and vines. For individual shrub plantings apply ½ pound of lime and ¼ pound of 8-8-8 per individual hole. Soils low in organic matter may be improved by incorporating organic matter in the form of peat, compost, aged sawdust, or well-rotted manure.

Planting

In the absence of a site-specific planting plan consider the following guidelines:

Shrubs

Late winter (before leaves emerge) is the best time for planting deciduous shrubs and early fall is the best for evergreens. Shrubs grown and marketed in containers can be planted anytime during the year except when the ground is frozen.

Individual Shrubs

Provide as large an area as possible for initial root development. The hole should be dug to a depth that allows the root ball to extend 1" above the soil surface and should be as big around as 3 to 5 times the diameter of the root ball.

Shrubs in Prepared Beds

Bed preparation differs somewhat from planting in individual holes. Bed areas are usually tilled or spaded, typically to a depth of 8" to 12". Contrary to the individual planting, soil amendments, such as peat or compost at a rate of 1 part amendment to 3 parts native soil, are beneficial to shrubs because they provide a uniform root environment across the bed area. This type of soil amendment also enables plants to respond positively to water and fertilizers when they are applied. The hole for the shrub planted in a bed area should be a few inches wider in diameter than the root ball.

Container Plants

Remove container plants from their containers, cutting the container if necessary. If the plant is root-bound (roots circling the outside of the root ball), score the roots from top to bottom about 4 times, cutting about ¼” deep with a knife, or gently massage the root ball until roots point outward. Place the shrub into the hole. Using only the native backfill, add soil back to the hole until it is ½ to ¾ full. Add water to the backfill soil around the root ball. Add soil to ground level and thoroughly water again. A small dike may be formed around the edge of the planting hole to hold water around the root ball if in sandy soils or on slopes.

Caution: In a tight clay soil, plants may be adversely affected by wetness caused by the clay soil trapping additional water in the root zone.

Bare Root Plants

Soak roots in water. When planting, spread the roots in the hole and gradually add soil. Firm the soil, being careful to avoid breaking roots. Fill the hole with water and allow it to drain. Then fill the hole with soil, and water again thoroughly.

Burlapped Plants

Cut any wire or string around the plants’ stems. Do not remove the burlap. Fold the burlap back so it will be buried by soil. Burlap which is allowed to remain exposed after planting can act as a wick, causing the root ball to dry out. From this point, follow the same procedure for filling the hole as that described for container plants.

Vines and Groundcovers

Early fall or early spring is the best time to plant vines and ground covers.

Transplanting to the prepared seedbed can be done using a small trowel or a spade. Make a hole large enough to accommodate the roots and soil. Backfill and firm the soil around the plant, water immediately, and keep well-watered until established. Water slowly and over long periods to allow for infiltration and reduce runoff.

Note: Most groundcovers are planted from container-grown nursery stock. Planting density determines how quickly full cover is achieved; one foot spacing is often used for rapid cover. Large plants such as junipers can be spaced on 3- foot centers.

Mulching

Apply mulch according to the site plan for the project. On slopes where erosion may be a problem and a plan is not available consider the following guidelines:

- Use a thick durable mulch such as shredded bark (not chips) or pine straw.
- On steep slopes, install erosion control netting or matting prior to planting, and tuck plants into the soil through slits in the net.
- Plant using a staggered pattern.

Watering

Shrubs

Water shrubs immediately after planting and water regularly for the first few weeks. Apply water weekly if rainfall does not supply 1” of water per week. Be conscious of plants that have been in the ground for less than 1 year and water them regularly and thoroughly during extended dry periods.

Vines and Groundcover

Water vines and groundcover immediately after planting and keep well-watered until established. Vines and groundcover need about an inch of water a week for the first 2 years after planting.

Installation Verification

Check all components of the practice during installation to ensure that specifications are being met.

Common Problems

Consult with a qualified design professional if any of the following occur:

- Soil compaction at planting time appears so significant that it will prevent adequate plant growth. Compaction should be addressed during site preparation.
- Design specifications for plants (species, variety, planting dates) and mulch cannot be met. Unapproved substitutions could lead to failure.

Problems that require remedial actions:

- Erosion, washout, and poor plant establishment – repair eroded surface, replant, reapply mulch and anchor.

- Mulch is lost to wind or stormwater runoffs – reapply mulch and anchor.

Maintenance

Replant shrubs, vines or groundcovers where needed to maintain adequate cover for erosion control. Repair eroded surfaces by reapplying the previous treatment and determine if an additional practice is needed, i.e., installing erosion netting. Maintain shrubs, vines, and ground covers with applications of fertilizer and mulching. Reapply mulch that is lost to wind, stormwater runoff or decomposition.

Shrubs, vines, and groundcovers need about an inch of water a week for the first 2 years after planting. When rain does not supply this need, shrubs should be watered deeply not less than once a week.

Fertilization needs should be determined by a professional because different plants have different needs. In the absence of a recommendation from a landscape professional, a soil test is the best way to determine what nutrient elements are needed. Fertilizer formulations of 12-4-8 or 15-0-15 can be used in the absence of a soil test. Apply 2 lbs of fertilizer per 1000 ft² of area.

This Page Intentionally Left Blank

Sodding (SOD)



Practice Description

Sodding is transplanting harvested sod to provide immediate ground cover. Sodding is well suited for stabilizing erodible areas such as grass-lined channels, slopes around storm drain inlets and outlets, diversions, swales, and slopes and filter strips that cannot be established by seed or that need immediate cover.

Typical Components of the Practice

- Plant Selection
- Surface Preparation
- Application of Soil Amendments (lime and fertilizer)
- Installing the Sod
- Irrigation
- Practice Verification
- Maintenance

Installation

Prior to start of installation, Typical Components of the Practice should be specified by a qualified design professional. Plans and specifications should be referred to by field personnel throughout the installation process.

Failure to remove compaction and to address pH and soil fertility deficiencies will likely cause a sodded stand to perform poorly or fail.

Plant Selection

Use plants specified in plan. If not specified, select a variety using Figure SOD-1 and Tables SOD-1 and SOD-2.

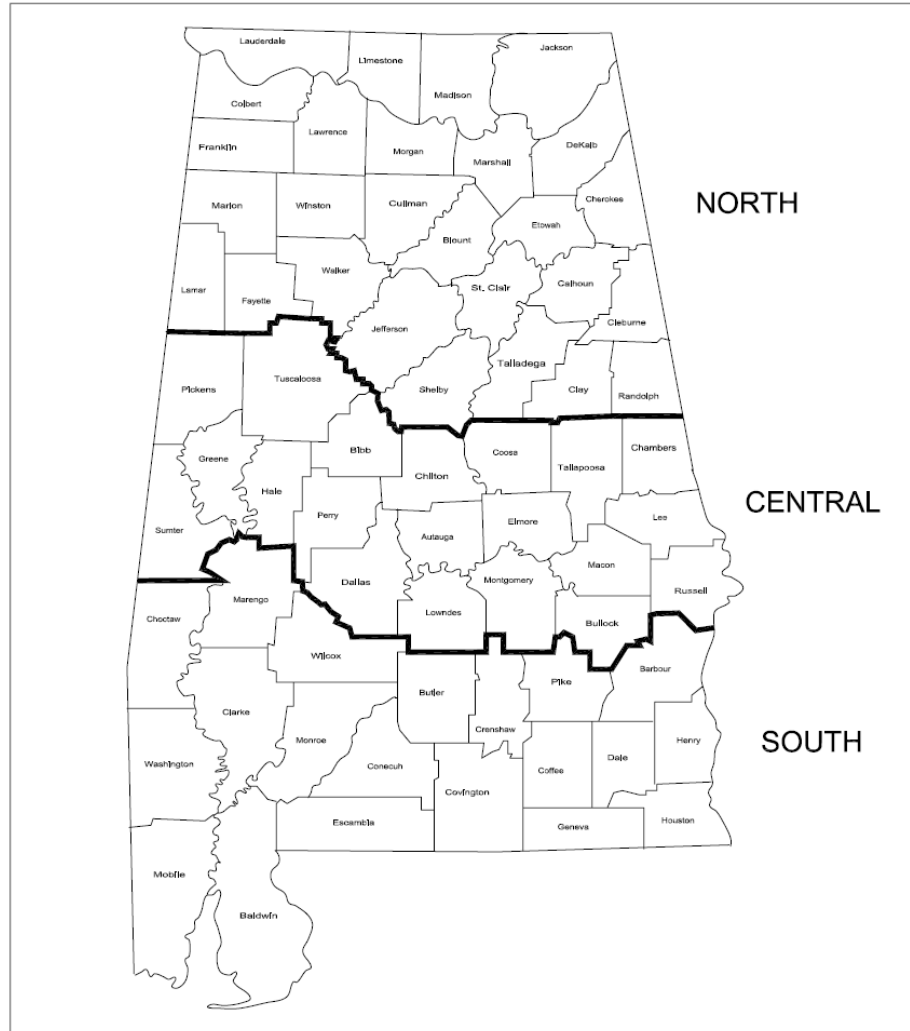

Figure SOD-1 Geographical Areas for Species Adaptation
Note: Site conditions related to soils and aspect in counties adjacent to or close to county boundaries may justify adjustments in adaptable areas by qualified design professionals.

Table SOD-1 Grasses Adapted for Sodding in Alabama

Warm Season Species	Variety	Area Adapted
Bermudagrass	Tifway, TifSport, Celebration, TifGrand, Common	North, Central, South
Bahiagrass	Pensacola	Central, South
Centipede	Common, TifBlair	Central, South
St. Augustine	Common, and a few commercial varieties	South
Zoysia	Any selection available in Alabama, Zenith is seeded	Central, South
Cool Season Species		
Tall Fescue	Kentucky 31, Rebel (turf type)	North

Table SOD-2 Adaptation and Maintenance of Grasses Used for Sodding

Species	Tolerance Ratings					Maintenance	
	Shade	Heat	Cold	Drought	Wear	Mowing Height	Mowing Frequency
Bermudagrass	No	Good	Poor	Excel.	Excel.	1"	High
Bahiagrass	Fair	Good	Poor	Excel.	Good	2-3"	High
Centipede	Fair	Good	Poor	Good	Poor	1 ½"	Low
Tall Fescue	Good	Fair	Good	Good	Good	3"	High
St. Augustine	Good	Good	Poor	Poor	Poor	2-3"	Medium
Zoysia	Fair	Good	Fair	Excel.	Good	1"	High

Surface Preparation

Clear the area of clods, rocks, etc. and smooth the area. Grade and loosen the soil to a smooth firm surface to enhance rooting. Break up large clods and loosen compacted, hard or crusted soil surfaces with a disk, ripper, chisel, harrow or other tillage equipment. Avoid preparing the seedbed under excessively wet conditions. Operate the equipment on the contour.

Where topsoiling is specified, additional steps will be done based on the design plan or, if not available, according to the Topsoiling practice.

Application of Soil Amendments

Apply fertilizer and lime according to the plan or by soil test recommendations. In the absence of a plan or soil test recommendations apply agricultural limestone at the rate of 2 tons per acre (90 lbs. per 1000 sq. ft.) and 10-10-10 fertilizer at the rate of 1000 lbs. per acre (25 lbs per 1000 ft.²) Apply ground agricultural limestone unless a soil test shows a pH of 6.0 or greater. Incorporate amendments to depth of 4" to 6" with a disk or rotary tiller.

Rake or harrow to achieve a smooth, final grade on which to lay the sod. Surface should be loose, and free of plants, trash and other debris.

During high temperatures, moisten the soil immediately prior to laying sod. This cools the soil and reduces root burning and dieback.

Installing the Sod

Lay the first row of sod in a straight line with subsequent rows placed parallel to and butting tightly against each other. Stagger joints to create a brick-like pattern and promote more uniform growth and strength. Ensure that sod is not stretched or overlapped and that all joints are butted tight to prevent spaces which would cause drying of the roots (See Figure SOD-2).

On slopes 3:1 or steeper, or wherever concentrated flow may be a problem, lay sod with staggered joints and secure by stapling or pegging. Install sod with the length perpendicular to the water flow (on the contour). See Figure SOD-3. Staple firmly at the corners and middle of each strip. Jute or synthetic netting may be pegged over the sod for further protection against washout during establishment. When netting is used consider wildlife friendly netting.

Irrigation

Immediately after laying the sod, roll or tamp it to provide firm contact between roots and soil, then irrigate sod deeply so that the underside of the sod pad and the soil 6" below the sod is thoroughly wet.

Until a good root system develops, water sod during dry periods as often as necessary to maintain moist soil to a depth of at least 4".

Practice Verification

Check materials and installation for compliance with specifications.

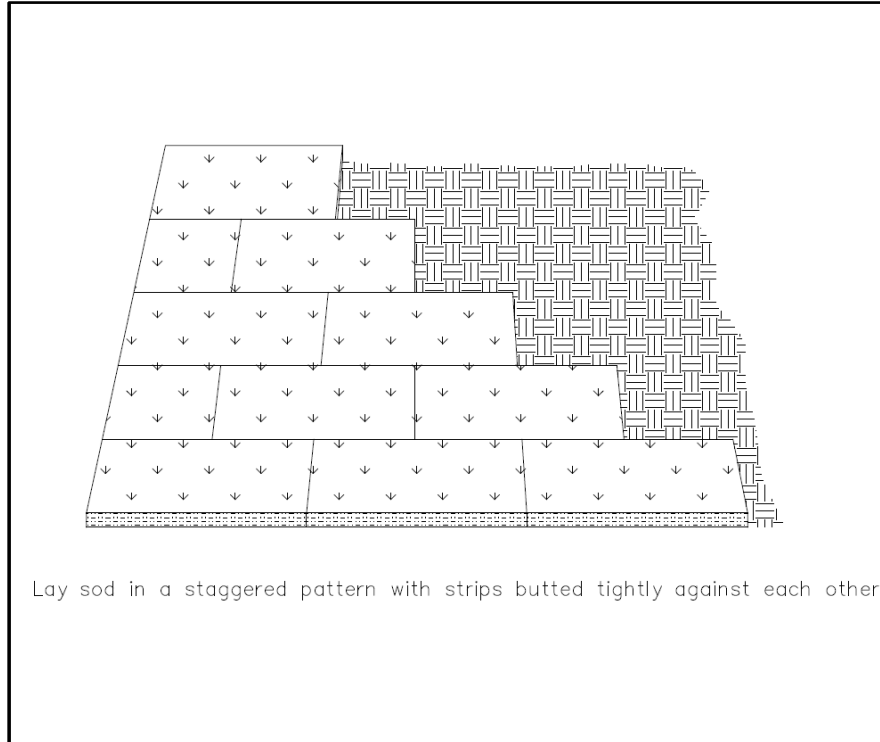

Figure SOD-2 Typical Installation of Grass Sod

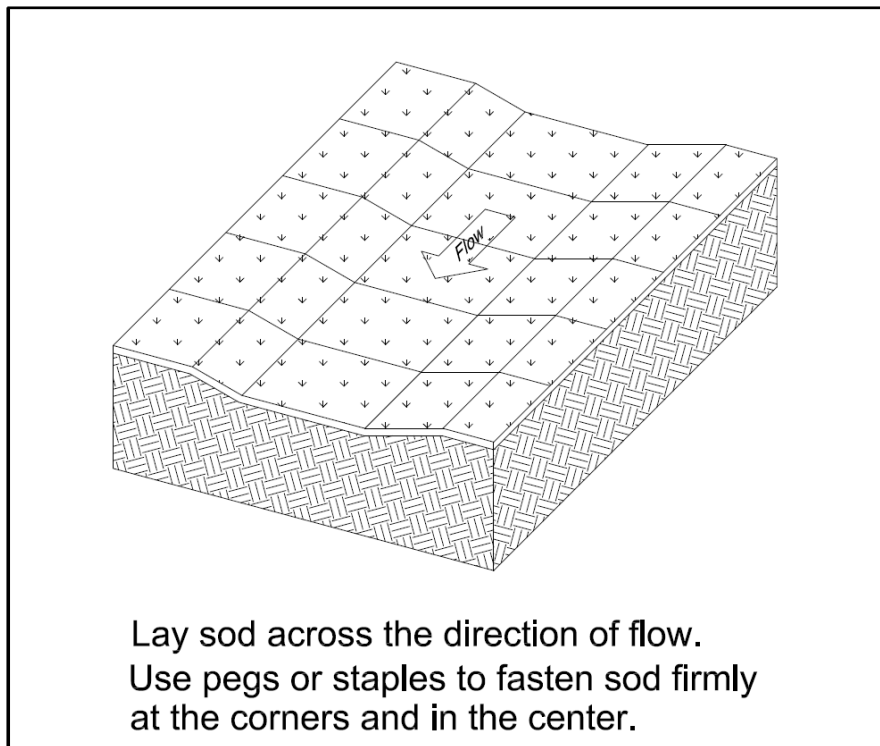

Figure SOD-3 Installation of Sod in Waterways

Common Problems

Consult with a qualified design professional if any of the following occur:

- Variations in topography on site indicate the sodding materials will not function as intended; changes in plan may be needed.
- Design specifications for sod variety cannot be met or irrigation is not possible; substitution or seeding may be required. Unapproved substitutions could result in erosion or sodding failure.
- Sod laid on poorly prepared soil or unsuitable surface and grass dies because it is unable to develop a root system with the soil: remove dead sod, prepare surface properly and resod.
- Sod not adequately irrigated after installation; may cause root dieback or grass does not root rapidly and is subject to drying out: irrigate sod and underlying soil to a depth of 4” and keep moist until roots are established.
- Sod not anchored properly may be loosened by runoff: use guidance under Site Preparation to repair the damaged areas, lay healthy sod, anchor properly and irrigate as planned.
- Slow growth due to lack of nitrogen: apply additional fertilizer.

Maintenance

Keep sod moist until it is fully rooted.

Mow to a height of 2” to 3” after sod is well-rooted, frequently in 2 to 3 weeks. Do not remove more than $\frac{1}{3}$ of the leaf blade in any mowing.

Permanent, fine turf areas require yearly fertilization. Fertilize warm-season grass in late spring to early summer; fertilize cool-season grass in early fall and late winter. Fertilize at rates recommended by a soil test.

Temporary Seeding (TS)



Practice Description

Temporary seeding is the establishment of fast-growing annual vegetation from seed. Temporary vegetation provides economical erosion control for up to a year and reduces the amount of sediment moving off the site.

This practice applies where short-lived vegetation can be established before final grading or in a season not suitable for planting the desired permanent species. It helps prevent costly maintenance operations on other practices such as sediment basins and sediment barriers. In addition, it reduces problems of mud and dust production from bare soil surfaces during construction. Temporary or permanent seeding is necessary to protect earthen structures such as dikes, diversions, grass-lined channels and the banks and dams of sediment basins.

Typical Components of the Practice

- Scheduling
- Seedbed Preparation
- Applying Soil Amendments (lime and fertilizer)
- Planting
- Mulching or Installation of Erosion Control Blanket
- Installation Verification
- Maintenance

Installation

Prior to start of installation, plant materials, seeding rates and planting dates should be specified by a qualified design professional. Plans and specifications should be referred to by field personnel throughout the installation process.

Plantings should be made during the specified planting period if possible. When sites become available to plant outside of the recommended planting period, either a temporary seeding, mulching or chemical stabilization should be applied. If lime and fertilizer application rates are not specified, take soil samples during final grading from the top 6" in each area to be seeded. Submit samples to a soil testing laboratory for lime and fertilizer recommendations.

Seedbed Preparation

Grade and loosen soil to a smooth firm surface to enhance rooting of seedlings and reduce rill erosion. If compaction exists, loosen the surface to 6" to 8". Break up large clods and loosen compacted, hard or crusted soil surfaces with a disk, ripper, chisel, harrow or other tillage equipment. Avoid preparing the seedbed under excessively wet conditions to minimize soil compaction. Operate the equipment on the contour.

For either broadcast seeding or drill seeding, loosen the soil to a depth of at least 6".

For no-till drilling, the soil surface does not need to be loosened unless the site has surface compaction. If shallow compaction exists, the area should be chiseled across the slope at least 6". If compaction exists between 6" and 12" the area should be chiseled or subsoiled at least 12".

Lime and fertilizer should be incorporated during seedbed preparation.

Applying Soil Amendments

Liming

Follow the design plan or soil test recommendation. If a plan or soil test is not available, use 2 tons/acre of ground agricultural lime on clayey soils (approximately 90 lbs/1,000 ft².) and 1 ton/acre on sandy soils (approximately 45 lbs/ft²).

Spread the specified amount of lime and incorporate into the upper 6" of soil following seedbed preparation and applying fertilizer.

Agricultural lime is usually applied as a separate operation and spread in dry form. It is not normally applied with a hydraulic seeder because it is abrasive and, also, may clog the system. On the other hand, liquid lime is applied with a hydraulic seeder but because of cost, liquid lime is used primarily to provide quick action for benefit of plants during their seedling stage with the bulk of

liming needs to be provided by agricultural lime. Dry lime may be applied with the fertilizer mixture.

Fertilizing

Apply a complete fertilizer at rates specified in the design plan or as recommended by soil tests. In the absence of soil tests, use the following as a guide:

8-24-24 or equivalent – apply 400 lbs/acre (approximately 9 lbs/1000 ft²) at planting.

When vegetation has emerged to a stand and is growing, 30 to 40 lbs/acre (approximately 0.8 lbs/1000 ft²) of additional nitrogen fertilizer should be applied.

Note: Fertilizer can be blended to meet exact fertilizer recommendations. Take soil test recommendations to local fertilizer dealer for bulk fertilizer blends. This may be more economical than bagged fertilizer.

Incorporate lime and fertilizer to a depth of at least 6” with a disk or rotary tiller on slopes of up to 3:1.

On steeper slopes, lime and fertilizer may be applied to the surface without incorporation. Lime and fertilizer may be applied together; however, fertilizer should not be added to the seed mixture during hydroseeding. Lime may be added with the seed mixture.

Planting

Plant the species specified in the plan at the rate and depth specified. In the absence of plans and specifications, plant species and seeding rates may be selected by qualified persons from Table TS-1.

Apply seed uniformly using a cyclone seeder, drop-type spreader, drill, drill seeder, cultipacker seeder, by hand, or with a hydroseeder on a fresh, firm friable seedbed.

When using a drill seeder, plant seed ¼” to ½” deep. Calibrate equipment in the field.

When planting by methods other than a drill seeder or hydroseeder, cover seed by raking, or dragging a chain, brush, or mat. Then firm the soil lightly with a roller. Seed can also be covered with a hydromulch product.

Cover broadcast seed by raking or chain dragging; then firm the surface with a roller or cultipacker to provide good seed contact. Small grains should be planted no more than 1” deep and grasses and legume seed no more than ½” deep.

Table TS-1 Commonly Used Plants for Temporary Cover¹

Species	Seeding Rate/Ac PLS ²	North	Central	South
		Seeding Dates		
Millet, Browntop or German	40 lbs	May 1-Aug 1	Apr 1-Aug 15	Apr 1-Aug 15
Rye	3 bu	Sept 1-Nov 15	Sept 15-Nov 15	Sept 15-Nov 15
Ryegrass	30 lbs	Aug 1-Sept 15	Sept 1-Oct 15	Sept 1 -Nov 15
Sorghum-Sudan Hybrids	40 lbs	May 1-Aug 1	Apr 15-Aug 1	Apr 1-Aug 15
Sudangrass	40 lbs	May 1-Aug 1	Apr 15-Aug 1	Apr 1-Aug 15
Wheat Common	3 bu	Sept 1-Nov 1	Sept 15-Nov 15	Sept 15-Nov 15
Common Bermudagrass	10 lbs	Apr 1-July 1	Mar 15-July 15	Mar 1-July 15
Crimson Clover	10 lbs	Sept 1-Nov 1	Sept 1-Nov 1	Sept 1-Nov 1

1 DO NOT USE Seeding Rates as part of a mixture unless shown as a mixture in this table.

2 PLS means Pure Live Seed and is used to adjust seeding rates. For example, to plant 10 lbs PLS of a species with germination of 80% and purity of 90%, $PLS = 0.8 \times 0.9 = 72\%$. $10\text{lbs PLS} = 10/0.72 = 13.9$ lbs of the species to be planted.

Hydroseeding

Surface roughening is particularly important when hydroseeding, as roughened slope will provide some natural coverage for lime, fertilizer, and seed. The surface should not be compacted or smooth. Fine seedbed preparation is not necessary for hydroseeding operations; large clods, stones, and irregularities provide cavities in which seeds can lodge.

Mix seed, inoculant if required, and a seed carrier with water and apply as a slurry uniformly over the area to be treated. The seed carrier should be a cellulose fiber, natural wood fiber or cane fiber mulch material which is dyed an appropriate color to facilitate uniform application of seed. Use the correct legume inoculant at 4 times the recommended rate when adding inoculant to a hydroseeder slurry. The mixture should be applied within one hour after mixing to reduce damage to seed.

Fertilizer should not be mixed with the seed-inoculant mixture because fertilizer salts may damage seed and reduce germination and seedling vigor. Fertilizer may be applied with a hydroseeder as a separate operation after seedlings are established.

Whenever possible, it is often best to incorporate lime and fertilizer with a disk.

Mulching

Mulching is extremely important for successful seeding. Whether the mulching material is straw or a hydraulic erosion control product (HECP, also referred to as hydromulch), the material needs to be applied properly. Uniformly spread organic mulches by hand or with a mulch blower at a rate which provides about 75% ground cover. Spread HECPs utilizing appropriate equipment and at rates as specified in the plan or by the manufacturer. Caution, an over-application of straw mulch (wheat, oat, or rye) will reduce stand success – do not over-apply straw mulch when mulching a seeding! (*See Mulching practice for more details*). In lieu of mulch, erosion control blanket may be used (see Erosion Control Blanket practice for more details).

Installation Verification

Check materials and installation for compliance with specifications during installation of products.

Common Problems

Consult with a qualified design professional if the following occurs:

- Design specifications for seed variety, seeding dates or mulching cannot be met; substitutions may be required. Unapproved substitutions could lead to failure.
- Seeding outside of the recommended results in an inadequate stand. Reseed according to specifications of a qualified design professional (see recommendations under Maintenance).

Maintenance

Reseeding

Inspect seedings weekly until a stand is established and thereafter at least monthly for stand survival and vigor. Also, inspect the site for erosion.

Eroded areas should be addressed appropriately by filling and/or smoothing, and reapplication of lime, fertilizer, seed, and mulch.

A stand should be uniform and dense for best results. Stand conditions, particularly the coverage, will determine the extent of remedial actions such as seedbed preparation and reseeding. A qualified design professional should be consulted to advise on remedial actions. Consider drill seeding when doing a remedial planting.

Fertilizing

If vegetation fails to grow, have the soil tested to determine whether pH is in the correct range or nutrient deficiency is a problem.

Satisfactory establishment may require re-fertilizing the stand, especially if the planting is made early in the planting season. Follow soil test recommendations or the specifications provided to establish the planting.

Mowing

Temporary plantings may be mowed and baled or simply mowed to compliment the use of the site.

Millet, sorghum-sudan hybrids, sudangrass, rye and wheat may be mowed, but no lower than 6" (closer mowing may damage the stand).

Ryegrass is tolerant of most mowing regimes and may be mowed often and as close as 4" to 6" if this regime is started before it attains tall growth (over 8").

Bermudagrass is tolerant of most mowing regimes and can be mowed often and close, if so desired, during its growing season.

Tree Planting on Disturbed Areas (TP)



Practice Description

Tree planting on disturbed areas is planting trees on construction sites or other disturbed areas to stabilize the soil. The practice reduces erosion and minimizes the maintenance requirements after a site is stabilized. The practice is applicable to those areas where tree cover is desired and is compatible with the planned use of the area, particularly on steep slopes and adjacent to streams. Tree planting is usually used with other cover practices such as permanent seeding or sodding.

Typical Components of the Practice

- Site Preparation
- Planting Seedlings and Trees
- Mulching
- Installation Verification
- Maintenance

Installation

Tree planting requirements should be designed by a qualified design professional and plans, and specifications should be made available to field personnel prior to start of planting.

Bare Root Seedlings

Site Preparation

Compacted soil should be ripped or chiseled on the contour to permit adequate root development and proper tree growth. Debris should be removed from the site to facilitate tree planting.

Planting

Planting should be done in accordance with the design plan. If a detailed plan is not available, select trees that are suitable for growing on the disturbed site. Select trees that are long-lived and are not considered invasive or a nuisance. Consideration should be given to trees that are visually pleasing and will provide food and cover for wildlife.

Bare-root seedlings should be planted between December 1 and March 15 when the soil is neither too dry nor too wet. Freezing weather should be avoided.

If planting is being done on sloping land by equipment, the planting should be made on the contour.

Bare-root seedlings should be planted deeper than they grew in the nursery: small stock 1" deeper and medium to large stock ½" deeper. On most soils longleaf pine seedlings should be planted ¼" deeper than they grew in the nursery (note: this not true for planting depth of container grown longleaf seedlings – see Site Preparation in next section for container grown seedlings). Roots should be planted straight down and not twisted, balled, or U-shaped. Soil should be packed firmly around the planted seedlings.

The roots of seedlings must be kept moist and cool at all times. After lifting at the nursery, seedlings should not be exposed to sun, wind, heating, drying or freezing before they are planted. Baled seedlings may be kept up to 3 weeks if they are properly stacked, watered, and kept in a cool place. When planting is delayed longer than 3 weeks, the roots of seedlings should be covered with moist soil (heeled-in) or the seedlings should be put in cold storage.

During planting, the roots of seedlings must be kept moist and only 1 seedling should be planted at a time. At the end of each day, loose seedlings should be either repacked in wet moss or heeled-in.

If specified, tree tubes and tree mats should be installed according to specifications or manufacturer's recommendations.

Mulching

Mulching may be necessary on sloping land to reduce erosion. Mulch with wood chips, bark, pine needles, peanut hulls etc. should be done to a depth of no more than 3". Mulch should not be placed against the trunk of a tree.

Balled and Burlapped and Container-Grown Trees

The best time to plant hardwood trees is in late winter (before leaves emerge) and the best time to plant evergreens is in early fall. However, these plants may be planted anytime of the year except when the ground is frozen. Watering is essential during dry periods.

Site Preparation

The planting hole should be dug deep and wide enough to allow proper placement of the root ball. The final level of the root ball's top should be level with the ground surface (See Figure TP-1).

As the hole is dug the topsoil should be kept separate from the subsoil. If possible, the subsoil should be replaced with topsoil. If topsoil is unavailable the subsoil can be improved by mixing in 1/3 volume of peat moss or well-rotted manure.

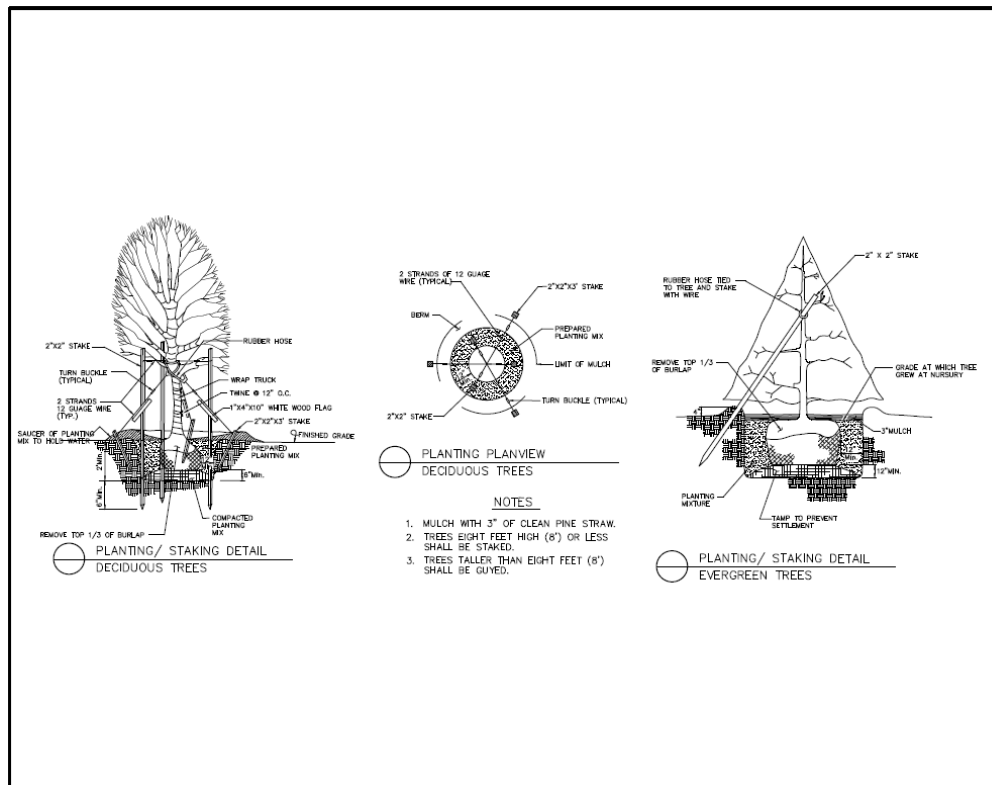

Figure TP-1 Tree Planting Diagram

Planting

Depth of planting must be close to the original depth. The tree may be set just a few inches higher than in its former location, especially if soil is poorly drained. Do not set the tree lower than before. For container grown longleaf seedlings, the planting depth should be slightly higher than the depth grown in the nursery. Soil to be placed around the root ball should be moist but not wet.

Set the tree in the hole and if the tree is balled and burlapped remove the rope which holds the burlap. Loosen the burlap and remove completely if practical. Do not break the soil of the root ball. Fill the hole with soil halfway and add water to settle the soil and eliminate air pockets. When the water has drained off, fill the hole the remainder of the way. Use extra soil to form a shallow basin around the tree. This will help retain water.

Newly planted trees may need artificial support to prevent excessive swaying. Stakes and guy wires may be used (See Figure TP-1). Guying should be loose enough to allow some movement of the tree.

Mulching

Following planting, mulch with wood chips, bark, pine needles, peanut hulls etc. to a depth of no more than 3". Mulch should not be placed against the trunk of the tree.

Mulching may be necessary on sloping land to reduce erosion and should be used around balled and burlapped trees and container grown trees to help conserve soil moisture and reduce competition from weeds and grass.

Installation Verification

Check all components of the practice during installation to ensure that specifications are being met.

Common Problems

Consult with a qualified design professional if any of the following occur:

- Soil compaction can prevent adequate tree growth. Compaction should be addressed during site preparation.
- Design specifications for trees (species, planting dates) and mulch cannot be met; substitutions may be required. Unapproved substitutions could lead to failure

Problems that require remedial actions:

Erosion, washout and poor tree establishment – repair eroded surface, replant, reapply mulch and anchor.

Mulch is lost to wind or stormwater runoff – reapply mulch and anchor.

Maintenance

Replant dead trees where needed to maintain adequate cover for erosion control.

Periodic fertilization may be beneficial on poor sites to maintain satisfactory tree growth. Transplanted trees should be fertilized 1 year or so after planting. A soil test is the best way to determine what elements are needed. Fertilizer formulations of 10-8-6 or 10-6-4 can be used in the absence of a soil test. About 2 lbs. of fertilizer should be used for each inch of tree diameter measured at 4.5 feet above the ground.

Fertilizer must come in contact with the roots to benefit a tree. The easiest way to apply fertilizer is to simply broadcast it under the tree and over the root system. As a tree grows, the roots will grow well beyond the drip line. This should be taken into account when applying fertilizer by the broadcast method. Another way to apply fertilizer is to make holes in the tree's root area with a bar or auger. Holes should be 18" deep, spaced about 2 feet apart, and located around the drip line of the tree. Distribute the fertilizer evenly into these holes and close the holes with the heel of the shoe or by filling with topsoil or peat moss. Trees should be fertilized in late winter or early spring before leaves emerge.

This Page Intentionally Left Blank

Check Dam (CD)



Practice Description

A check dam (also referred to as a “ditch check”) is a barrier constructed across a conveyance to impound water for the purpose of velocity reduction by flattening the flow gradient and reducing shear stress within the channel. This practice applies in small open channels and drainageways, including temporary and permanent swales.

Check dams are not to be used in a live stream. Situations of use include areas in need of protection during establishment of grass and areas that cannot receive a temporary or permanent non-erodible lining for an extended period.

Typical Components of the Practice

- Site Preparation
- Materials Installation
- Erosion and Sediment Control
- Construction Verification
- Maintenance

Construction

Prior to start of construction a qualified design professional should determine the location, elevation, and size of the structure to optimize flattening of channel grade. Usually, check dam dimensions are taken from a standard drawing. Check dams are typically constructed using materials specified in a contract which

could be rock, wattles, sand bags, or other suitable material, including manufactured products. Most check dams are constructed of rock.

Site Preparation

Determine location of any underground utilities.

Locate and mark the site for each check dam in strategic locations (to avoid utilities and optimize effectiveness of each structure in flattening channel grade).

Remove debris and other unsuitable material which would interfere with proper placement of the check dam materials.

In highly erosive soil conditions it may be specified to excavate a shallow keyway (12"-24" deep and at least 12" wide) across the channel and into each abutment for each check dam. For other soils, geotextile alone without a keyway is often used on the soil.

Materials Installation

For all check dams on compacted soil, install a non-woven geotextile fabric underlayment that extends at least 3 feet up and downstream of the check dam. Bury the upstream edge of the geotextile underlayment, staple it to the trench bottom, and place compacted backfill in the trench. Ensure the geotextile is secured by stapling along its edges.

Always ensure that water flows over and not around the check dam.

Rock Check Dam. Construct the dam of the class riprap specified with a minimum 2:1 side slopes. Position rock to form a parabolic top, perpendicular to channel flow, with the center portion at the elevation shown in the design so that the flow goes over the structure and not around the structure. Small graded aggregate and/or geotextile may be specified on the upstream face of the rock check dam to increase the sediment trapping efficiency.

Wattle Check Dam. Place the specified wattle in a parabolic shape to ensure water flows over and not around the wattle. Staple the wattle in place with sod staples on approximate 6-inch centers on each side of the wattle to prevent flotation, and place wooden stakes over the top in a non-destructive tee-pee fashion.

Silt Fence Check Dam. Construct the silt fence check dam in an upstream "V" configuration and notch the silt fence as shown on the plans.

Sand Bag Check Dam. Ensure the sand bags are properly oriented in each layer as shown on the plans.

Erosion and Sediment Control

Install vegetation (temporary or permanent seeding) or mulching to stabilize other areas disturbed during the construction activities.

Construction Verification

Check finished size, grade and shape for compliance with standard drawings and materials list (check for compliance with specifications if included in contract specifications).

Common Problems

Consult with a qualified design professional if any of the following occur:

- Variations in topography on site indicate check dam will not function as intended. Change in plan will be needed.
- Materials specified in the plan are not available.

Maintenance

Inspect the check dam for material displacement and abutments for erosion around the ends of the dam after each significant rainfall event. Repair as needed.

Inspect the channel after each significant rainfall event. If channel erosion exceeds expectations, consult with the design professional and consider adding another check dam to reduce channel flow grade.

Sediment should be removed if it reaches a depth of $\frac{1}{2}$ the original dam height. If the area behind the dam fills with sediment, there is a greater likelihood that water will flow around the end of the check dam and cause the practice to fail.

Check dams should be removed when their useful life has been completed. The area where check dams are removed should be stabilized immediately. In rare instances check dams should be left as a permanent measure to support channel stability.

This Page Intentionally Left Blank

Diversion (DV)



Practice Description

A diversion is a watercourse constructed on a designed grade, across a slope, and consisting of an excavated channel, a compacted ridge, or a combination of both.

This practice applies to sites where stormwater runoff can be redirected to permanently protect structures or areas downslope from erosion, sediment, and excessive wetness or localized flooding. Diversions may be used to temporarily divert stormwater runoff to protect disturbed areas and slopes or to retain sediment on-site during construction.

Typical Components of the Practice

- Site Preparation
- Grading
- Erosion and Sediment Control
- Construction Verification
- Maintenance

Construction

Prior to start of construction, diversions should be designed by a qualified design professional. Plans and specifications should be referred to by field personnel throughout the construction process. A diversion should be built according to

planned alignment, grade, and cross section. Typically, a diversion is constructed with the following activities.

Site Preparation

Determine exact location of any underground utilities.

Locate and mark the alignment of the diversion as shown on the plans. Minor adjustments to the grade and alignment may be required to meet site conditions. The alignment should maintain a positive grade towards the outlet and end in a stable outlet or an area that can be stabilized.

Clear the construction area of trees, stumps, brush, sod and other unsuitable material which would interfere with compaction of the ridge.

Disk or scarify the area where the ridge is to be installed before placing the fill.

Clean out and refill with compacted earth fill all ditches, swales or gullies to be crossed.

Apply gravel or hard surface protection at vehicle crossings to prevent rutting.

Install stable outlets prior to construction. Adequate vegetation should be established in the outlet channel. If vegetation cannot be established use Lined Swale, Rip-rap Lined Swale, Drop Structure, Sediment Basin or Stormwater Detention Basin .

Grading

Excavate, fill and shape the diversion to planned alignment, grade and cross section. The channel should have a positive grade toward the outlet to avoid ponding. Where possible, blend diversion into the surrounding landscape.

Overfill and compact the ridge, allowing for 10% settlement. Fill should be placed in lifts of no more than 6" to 8" in depth. Compaction may be achieved by driving wheeled equipment along the ridge as lifts are added. The settled ridge top must be at or above design elevation at all points.

All soil removed and not needed for the practice should be spread or disposed of so that it will not interfere with the functioning of the diversion.

Erosion and Sediment Control

Control sediment along grading limits with sediment control measures.

Leave sufficient area adjacent to the diversion to permit clean out and regrading.

Immediately after installation install vegetation treatment or other means to stabilize the diversion in accordance with plans.

Installation and Maintenance of Best Management Practices

Install gravel or hard surface protection at vehicle crossings.

Stabilize diversion outlets in accordance with plans.

Construction Verification

Check finished grades and cross section of diversions to eliminate constrictions to flow. Check all ridges for low spots and stability.

Common Problems

Consult with a qualified design professional if any of the following occur:

- Variations in topography on site indicate diversion will not function as intended. Changes in plans will be needed.
- Design specifications for seed variety or seeding cannot be met. Substitutions not approved by the design professional could result in erosion and lead to diversion failure.
- Seepage is encountered during construction. It may be necessary to install drains.

Maintenance

Inspect weekly and following each storm event for erosion until the diversion is vegetated.

Remove debris and sediment from the channel, and rebuild the ridge to design elevation where needed.

Check diversion outlet for erosion and repair if area becomes unstable. Maintain vegetation with periodic fertilization and mowing to keep vegetation in a vigorous, healthy condition. Mow for weed and brush control during the first year and as needed to prevent brush and trees seedlings from becoming established after the first year of installation.

When the work area has been stabilized, remove temporary diversions, sediment barriers and traps and repair bare or damaged areas in the vegetation by planting and mulching or sodding.

Stabilize all eroded, rutted or disturbed areas as soon as possible with vegetation or synthetic erosion control measures as specified in the design.

This Page Intentionally Left Blank

Drop Structure (DS)



Practice Description

A drop structure is an erosion control structure created by construction of a barrier across a drainageway or installing a permanent manufactured product down a slope. The purpose of a drop structure is to convey concentrated flow storm runoff from the top to the bottom of a slope or to lower water from a grassed swale into an open channel such as an intermittent or perennial stream. This practice applies where other erosion control measures are insufficient to prevent excessive erosion and off-site sedimentation.

Typical Components of the Practice

- Site Preparation
- Principal Spillway
- Embankment
- Emergency Spillway
- Erosion Control
- Construction Verification
- Maintenance

Construction

Prior to the start of construction, drop structures should be designed by a qualified design professional.

Plans and specifications should be referred to by field personnel throughout the construction process. The drop structure should be built according to planned grades and dimensions.

Note: Construction of an embankment with spillways is the only type of drop structure covered in this edition of the handbook.

Consider the following guidance as construction proceeds

Site Preparation

Locate all utilities at the site to ensure avoidance.

Clear, grub and strip the dam foundation and emergency spillway area, removing all woody vegetation, rocks and other objectionable material. Dispose of trees, limbs, logs and other debris in designated disposal areas.

Stockpile surface soil for use later during topsoiling.

Clear the sediment pool to facilitate sediment clean out and dispose of trees, limbs, logs and other debris in designated disposal areas.

Principal Spillway

Prepare the pipe bedding and situate the spillway barrel (pipe) on a firm, even foundation.

Install anti-seep collars, or sand drainage diaphragm with filter compatible outlet according to the design plan.

Place around the barrel 4" layers of moist, clayey, workable soil (not pervious material such as sand, gravel or silt), and compact with hand tampers to at least the density of the foundation soil. (Do not raise the pipe from the foundation when compacting under the pipe haunches.)

At the pipe inlet, install Inlet Protection according to the design plan.

At the pipe outlet, install Outlet Protection according to the design plan (if not specific, use a riprap apron at least 5 feet wide to a stable grade).

Embankment

Scarify the foundation of the dam before placing fill. Use fill from predetermined borrow areas. It should be clean, stable soil free of roots, woody vegetation, rocks, and other debris; and must be wet enough to form a ball without crumbling, yet not so wet that water can be squeezed out.

Place the most permeable soil in the downstream toe and the least permeable in the center portion of the dam.

Protect the spillway barrel with 2 feet of fill that has been compacted with hand tampers before traversing over the pipe with equipment.

Compact the fill material in 6" to 8" continuous layers over the length of the embankment. One way is by routing construction equipment so that each layer is traversed by at least one wheel of the equipment.

A sand drainage diaphragm should be completed along with the fill material.

Construct and compact the embankment to an elevation 10% above the design height to allow for settling. The embankment should have a minimum 8 feet top width and 3:1 side slopes, but the design may specify additional width and gentler side slopes.

Emergency Spillway

Construct the spillway at the site located by the qualified design professional according to the plan design (in undisturbed soil around one end of the embankment on natural ground, and so that any flow will return to the receiving channel without damaging the embankment).

Erosion Control

Minimize the size of all disturbed areas.

Use temporary diversions to prevent surface water from running onto disturbed areas.

Vegetate and stabilize the embankment, the emergency spillway, and all disturbed areas immediately after construction.

Construction Verification

Check the finished grades and configuration for all earthwork. Check elevations and dimensions of all pipes and structures.

Common Problems

Consult with a qualified design professional if any of the following occur:

- Variations in topography on site indicate drop structure will not function as intended.
- Seepage is encountered during construction; it may be necessary to install drains.
- Design specifications for fill, pipe, seed variety or seeding dates cannot be met; substitutions may be required. Unapproved substitutions could lead to failure.

Maintenance

Inspect the drop structure after each storm event until it is completely stabilized with vegetation.

Periodically check the embankment, emergency spillway and outlet for erosion damage, piping, settling, seepage or slumping along the toe or around the barrel and repair immediately.

Grass Swale (GS)



Practice Description

A grass swale is a natural or constructed channel with established permanent grasses used for water quality or to convey stormwater runoff which does not rely on the permeability of the soil as a pollutant removal mechanism. This practice applies to sites where concentrated runoff will cause erosion damage, a vegetative lining provides sufficient stability for the channel as designed, and space is available for a relatively large cross section. Typical situations where concentrated flow areas are addressed with a grass swale include roadside ditches, channels at property boundaries, outlets for diversions and other concentrated flow areas subject to channel erosion. Grassed swales are generally considered permanent structures but may be used as a temporary measure.

Typical Components of the Practice

- Scheduling
- Site Preparation
- Constructing
- Vegetating
- Construction Verification
- Maintenance

Installation

Prior to start of construction, grass swale channels should be designed by a qualified design professional. Plans and specifications should be referred to by

field personnel throughout the construction process to ensure that the channel has planned alignment, grade, and cross section.

Scheduling

Schedule construction during a period of relatively low rainfall and runoff events if practical. Consider, also, the establishment period (planting dates) for the planned species that will be used for long-term vegetative cover.

Site Preparation

Determine exact location of underground utilities.

Install any structures required to stabilize the swale outlet or to provide drainage along the swale prior to beginning installation of the swale. Refer to design for structures to be installed.

Remove brush, trees and other debris from the construction area and dispose of properly.

Constructing

Excavate and shape the channel to dimensions shown in the design specifications, removing and properly disposing of excess soil so surface water can enter the channel freely. The typical features of a grass swale are shown in Figure GS-1 and listed below, but may be different in the design for a specific site:

- Cross Section: trapezoidal or parabolic.
- Side Slopes: 3:1 or flatter for trapezoidal channels.
- Outlet: Channel should empty into a stable outlet, sediment traps, or detention/retention basins.
- Subsurface Drain: Use in areas with seasonally high water tables or seepage problems.
- Topsoil: Provide topsoil as needed to grow grass on areas disturbed by construction.

Protect all concentrated inflow points along the channel with erosion resistant linings, such as riprap, sod, mulch, erosion control blankets, turf reinforcement mats or other appropriate practices as specified in the design plan.

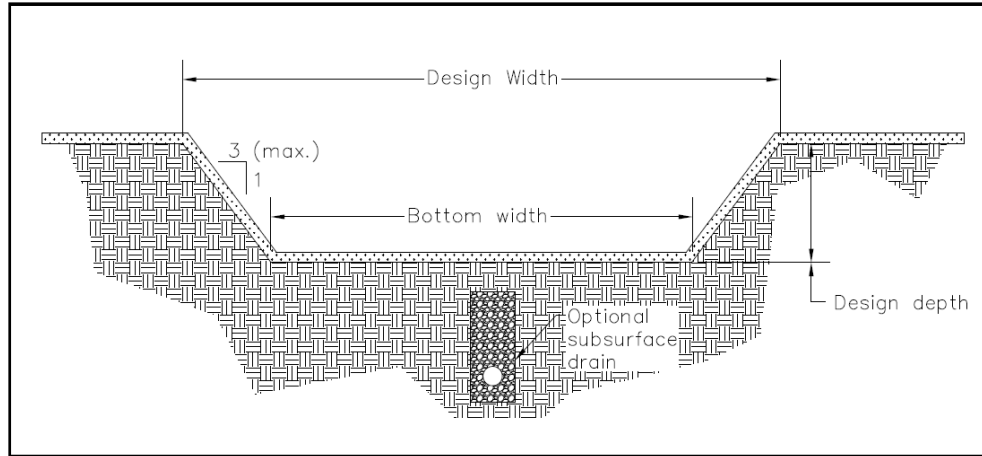

Figure GS-1 Typical Trapezoidal Grass-lined Channel

Vegetating

Prepare seedbed and apply lime, fertilizer and seed or sod in the swale immediately after grading and protect with erosion control blankets, turf reinforcement mats or mulch according to the design plan. If not specified in a plan, select lime, fertilizer, seed variety and mulching components from related practices – permanent seeding or temporary seeding, erosion control blanket or sodding.

Construction Verification

Check finished grade and cross section of channel throughout the length of the watercourse. Verify channel cross sections at several locations to avoid constrictions to flow. Check materials and installation of vegetation components for compliance with specifications during installation of vegetative materials.

Common Problems

Consult with a qualified design professional if any of the following occur:

- Variations in topography on site indicate practice will not function as intended. Changes in plan may be needed.
- Design specifications for seed variety, seeding dates or erosion control materials cannot be met; substitution may be required.
- Erosion occurs in channel before vegetation is fully established.
- Erosion occurs at channel outlet before vegetation is fully established.
- Sediment is deposited at channel outlet before vegetation is fully established.

Maintenance

Inspect the channel following storm events both during and after grass cover is established and make needed repairs immediately.

Check the channel outlet and road crossings for blockage, ponding, sediment, and bank instability, breaks and eroded areas. Remove any blockage and make repairs immediately to maintain design cross section and grade.

Lined Swale (LS)



Practice Description

A lined swale is a constructed channel with a permanent lining designed to carry concentrated runoff without channel erosion to a stable outlet. This practice applies where grass swales are unsuitable because of conditions such as steep channel grades, prolonged flow areas, soils that are too erodible or not suitable to support vegetation or insufficient space and where riprap-lined swales are not desired.

The material that provides the permanent lining may be concrete, manufactured concrete products, tied concrete block mats, or turf reinforcement mat (TRM).

Typical Components of the Practice

- Site Preparation
- Material Placement
- Stabilization
- Construction Verification
- Maintenance

Construction

Prior to start of construction, lined swales should be designed by a qualified design professional and specifications should be available to field personnel.

Plans and specifications should be referred to by field personnel throughout the construction process.

Note: Concrete lined channel is the only lining method that is covered in this edition of the handbook. There are numerous permanent erosion control blankets (TRMs) and manufactured concrete products available with similar applications and their unique installation procedures should be obtained from the manufacturer of the product being used. In addition, Riprap-lined Swale is covered in this handbook as a separate practice.

Site Preparation

Determine exact location of underground utilities.

Remove brush, trees and other debris from the channel and spoil areas and dispose of properly.

Grade or excavate cross section to the lines and grades shown in design for the concrete subgrade.

Remove soft sections and unsuitable material and replace with suitable material. The subgrade should be thoroughly compacted and shaped to a smooth, uniform surface.

Material Placement

Place forms to meet the specific plan design for the project and place concrete of the designed mix into the forms according to construction specifications.

Construction and expansion joints should be used where swale length exceeds 10 feet. Construction joints should be spaced at 10 foot intervals and expansion points at intervals not to exceed 20 feet.

The subgrade should be moist at the time the concrete is placed.

Place concrete for the lined channel to the thickness shown on the plans and finish it in a workmanlike manner.

Coat the concrete with an approved curing compound as soon as finish work is complete and the free water has disappeared from the surface.

Provisions should be made to protect the freshly poured concrete from extreme temperatures to ensure proper curing.

Stabilization

Stabilize channel inlet and outlet points according to the design plan.

Stabilize adjacent disturbed areas after construction is completed with a vegetation treatment (permanent or temporary seeding) and mulching. Provide topsoil, lime and fertilizer as needed to grow grass on areas disturbed by

construction. Many design plans specify a row of sod at the edges of the concrete channel.

If not specified in a plan, select lime, fertilizer, seed variety and mulching components from related practices – Permanent Seeding or Temporary Seeding and Mulching, Erosion Control Blankets or Sodding.

Construction Verification

Check finished grades and cross sections throughout the length of the channel. Verify channel cross section dimensions at several locations to avoid flow constrictions.

Common Problems

Consult with a qualified design professional if any of the following occur:

- Variations in topography on site indicate practice will not function as intended; changes in plan may be needed.
- Design specifications cannot be met; substitution may be required. Unapproved substitutions could result in failure of the practice.

Maintenance

Inspect lined channel at regular intervals and after storm events. Check for erosion adjacent to the channel, at inlets and outlets and underneath the lined channel.

Give special attention to the channel inlet and outlet and repair eroded areas promptly.

Inspect for erosion and repair with appropriate vegetative treatment (permanent or temporary seeding and mulching).

This Page Intentionally Left Blank

Outlet Protection (OP)



Practice Description

Outlet Protection is an erosion control practice designed to prevent erosion at the outlet of a channel or conduit by reducing the velocity of flow and dissipating the energy. This practice applies wherever high velocity discharge must be released on erodible material.

Typical Components of the Practice

- Site Preparation
- Installation of Riprap Structures
- Installation of Concrete Structures
- Erosion Control
- Construction Verification
- Maintenance

Construction

Prior to start of construction, the practice should be designed by a qualified design professional. Plans and specifications should be referred to by field personnel throughout the construction process.

The structure should conform to the dimensions, grades and alignments shown on the plans and specifications.

Site Preparation

Completely remove stumps, roots and other debris from the construction area. Fill depressions caused by clearing and grubbing operations with clean, non-organic soil. Grade the site to the lines and grades shown on the plans. Compact any fill required in the subgrade to the density of the surrounding undisturbed material.

If possible, the alignment should be straight throughout its length. If a curve is required, it should be located in the upstream section of the outlet.

Riprap Structures

Ensure that the subgrade for the filter and riprap follows the required lines and grades shown in the plan. Low areas in the subgrade on undisturbed soil may also be filled by increasing the riprap thickness.

Geotextile fabric must meet design requirements and be properly protected from puncturing or tearing during installation. Repair any damage by removing the riprap and placing another piece of fabric over the damaged area. All connecting joints should overlap a minimum of 1.5 feet with the upstream edge over the downstream edge. If the damage is extensive, replace the entire geotextile fabric.

Riprap may be placed by equipment. Care should be taken to avoid damaging the fabric.

Construct the apron on zero grade with no overfall at the end. Make the top of the riprap at the downstream end level with the receiving area or slightly below it.

Concrete Structures

Reinforcing steel and welded wire fabric should be placed in strict accordance with the design plans and maintained in the proper position during the pouring of concrete. Concrete should be placed in horizontal layers not exceeding 24" in thickness or as specified in the design, and consolidated by mechanical vibrating equipment supplemented by hand-spading, rodding or tamping.

Concrete should be placed in sturdy wood or metal forms, adequately supported to prevent deformation. Forms should be oiled with form release agent prior to placement to prevent bonding between concrete and forms.

If possible, concrete should not be placed during inclement weather or periods of temperature extremes. If temperature extremes cannot be avoided, American Concrete Institute (ACI) guidelines for placement of concrete during such extremes should be consulted.

Concrete should be allowed to cure as required by the plans and specifications.

Installation and Maintenance of Best Management Practices

Typically, the surface should be kept wet during curing by covering it with wet burlap sacks or other means. Design strengths should be confirmed by laboratory tests on representative cylinders made during concrete placement. Form work should not be removed prior to the specified time.

Erosion Control

Immediately after construction, stabilize all disturbed areas with vegetation.

Construction Verification

Check finished structures for conformance with design specifications.

Common Problems

Consult with a qualified design professional if any of the following occur:

- Variations in topography on site indicate measure will not function as intended.
- Design specifications for riprap, geotextile fabric, concrete, reinforcing steel or backfill cannot be met; substitutions may be required. Unapproved substitutions could lead to failure.
- Problems with the structure develop during or after installation.

Maintenance

Inspect riprap outlet structures after heavy rains to see if any erosion around or below the riprap has taken place or if stones have been dislodged. Check concrete structures for cracks and movement. Immediately make all needed repairs to prevent further damage.

This Page Intentionally Left Blank

Riprap-lined Swale (RS)



Practice Description

A riprap-lined swale is a natural or constructed channel with an erosion-resistant rock lining designed to carry concentrated runoff to a stable outlet. This practice applies where grass swales are unsuitable because of conditions such as steep channel grades, prolonged flow areas, soils that are too erodible or not suitable to support vegetation or insufficient space.

Typical Components of the Practice

- Site Preparation
- Foundation Stabilization
- Rock Placement
- Outlet Stabilization
- Construction Verification
- Maintenance

Construction

Prior to start of construction, riprap-lined swales should be designed by a qualified design professional.

Plans and specifications should be referred to by field personnel throughout the construction process.

Site Preparation

Determine exact location of underground utilities.

Remove brush, trees and other debris from the channel and spoil areas and dispose of properly.

Grade or excavate cross section to the lines and grades shown in design. Over excavate to allow for thickness of riprap and filter material. Foundation excavation not deep enough or wide enough may cause riprap to restrict channel flow and result in overflow and erosion. Side slopes are usually 2:1 or flatter.

Foundation Stabilization

Install geotextile fabric or aggregate in the excavated channel as a foundation for the riprap. Anchor fabric in accordance with design specifications. If the fabric is omitted or damaged during stone placement there may be settlement failure and bank instability.

Installation

As soon as the foundation is prepared, place the riprap to the thickness, depth and elevations shown in the design specifications. It should be a dense, uniform and well-graded mass with few voids. Riprap should consist of a well-graded mixture of stone (size and gradation as shown in design specifications) that is hard, angular, and highly chemical and weather resistant. Larger stone should predominate, with sufficient smaller sizes to fill the voids between the stones. The diameter of the largest stone size should be not greater than 1.5 times the d_{50} size. Minimum thickness of riprap liner should be 1.5 times the maximum stone diameter.

Blend the finished rock surface with the surrounding land surface so there are no overfalls, channel constrictions or obstructions to flow.

Outlet Stabilization

Stabilize channel inlet and outlet points. Extend riprap as needed.

Stabilize adjacent disturbed areas after construction is completed.

Construction Verification

Check finished grades and cross sections throughout the length of the channel.

Verify channel cross section dimensions at several locations to avoid flow constrictions.

Common Problems

Consult with a qualified design professional if any of the following occur:

- Variations in topography on site indicate channel will not function as intended; changes in plan may be needed.
- Design specifications for riprap sizing, geotextile fabric or aggregate filter cannot be met; substitution may be required. Unapproved substitutions could result in channel erosion.

Maintenance

Inspect channels at regular intervals and after storm events. Check for rock stability, sediment accumulation, soil piping, and scour holes throughout the length of the channel.

Look for erosion at inlets and outlets.

When stones have been displaced, remove any debris and replace the stones in such a way as to not restrict the flow of water.

Give special attention to outlets and points where concentrated flow enters the channel and repair eroded areas promptly by extending the riprap as needed.

This Page Intentionally Left Blank

Subsurface Drain (SD)



Practice Description

A subsurface drain is a perforated pipe and/or a continuous layer of porous material installed below the ground surface that intercepts, collects and carries excessive groundwater to a stable outlet. The practice improves soil moisture, vegetative growth, and ground stability. Subsurface drains may reduce wet ground from interfering with construction activities. This practice applies where groundwater is at or near the ground surface or where adequate drainage cannot be provided for surface runoff.

Typical Components of the Practice

- Site Preparation
- Trench Excavation
- Installation of Drain Pipe, Bedding Material and Filter Cloth
- Backfill Installation
- Installation of Clean-Out Device
- Outlet Installation
- Stabilization
- Safety
- Construction Verification
- Maintenance

Construction

Prior to start of construction, subsurface drains should be designed by a qualified design professional. Materials such as sand, gravel, geotextile filter cloth and pipe must be properly designed in order for the subsurface drain system to function properly. Plans and specifications should be available to field personnel.

Site Preparation

Determine exact location of underground utilities. At least 3 days prior to construction, request Alabama Line Location Center (dial 811) to mark all underground utilities within the project area.

Locate and mark the alignment of the drains as shown on the design plans.

Clear installation area of debris and obstacles, such as trees and stumps, that might hinder grading and installation of the subsurface drain.

Trench Excavation

Excavate the trench to the specified depth and grade shown in the design plan. To accommodate the sand/gravel bedding and filter material, excavate the trench to the depth specified below the design bottom elevation of the pipe. Ensure trenching meets OSHA requirements.

Place materials excavated from the trench on the up gradient side of the trench to prevent water from entering the trench during construction.

Grade the trench to prevent siltation into the drain.

Installation of Drain Pipe, Bedding Material and Geotextile Filter Cloth

Line trench with coarse sand, filter cloth (if specified), and small aggregate providing enough material to overlap over the top of the finished gravel bedding. This helps prevent movement of soil into the gravel.

Spread coarse sand and small aggregate as specified in the design plan.

Lay pipe on the design grade and elevation avoiding reverse grade or low spots after checking to ensure the pipe meets specifications.

Cap the upper end of each drain with a standard cap made for this purpose or with concrete or other suitable material to prevent soil from entering the open end.

Installation and Maintenance of Best Management Practices

Place bedding material around pipe, on all sides, with the amount shown in the design plan.

Fold filter cloth (if specified) over the top of the gravel bedding.

Backfill Installation

Backfill immediately after placement of the pipe and bedding. Ensure that the material does not contain rocks or other sharp objects and place it in the trench in a manner that will not damage or displace the pipe. Overfill the trench slightly to allow for settlement.

Installation of Clean-Out Device

Install clean-outs for maintenance of the subsurface drain in the locations shown on design plan.

Outlet Installation

Construct the outlet of the subsurface drain at the elevation in the design plan. The outlet section of the drain should be at least 10 feet of non-perforated corrugated metal, cast iron, steel or heavy-duty plastic pipe. Cover at least half of the pipe length with well-compacted soil. Place a suitable animal guard securely over the pipe outlet to keep out rodents.

Stabilization

Keep the settled fill over the pipe outlet slightly higher than the surrounding ground to prevent erosion, rills and gullies.

Stabilize all bare areas of the trench with temporary seeding and mulching unless construction will disturb the area within 13 days.

Safety

Narrow trenches are subject to collapse and can be a safety hazard to persons in the trench. No person should enter a trench without shoring protection or properly sloping the sides of the trench.

Construction Verification

Verify the dimensions during construction with those shown on the plans for location, length, depth and cross section of trench.

Verify the dimensions and specifications of the sand and aggregate used in the bedding and manufactured materials such as pipe, tile or panel drain.

Common Problems

Consult with a qualified design professional if any of the following occur:

- Variations in topography on-site indicate subsurface drains will not function as intended or originally designed.
- Design specifications for sand, aggregate or manufactured products cannot be met; substitutions may be required. Unapproved substitutions could result in failure of the drain to function as intended.
- Pipe is crushed by construction traffic.

Maintenance

Check subsurface drains periodically to ensure that they are free-flowing and not clogged with sediment.

Keep outlet clean and free of debris.

Keep surface inlets open and free of sediment and other debris.

Where drains are crossed by heavy vehicles, check the pipe to ensure that it is not crushed.

Temporary Slope Drain (TSD)



Photo courtesy of CPESC, Inc.

Practice Description

A temporary slope drain is a pipe or other conduit designed to convey concentrated runoff down the face of a cut or fill slope without causing erosion. This practice applies wherever concentrated stormwater runoff must be conveyed down a steep slope.

Typical Components of the Practice

- Site Preparation
- Erosion Control
- Construction Verification
- Maintenance

Construction

Prior to start of construction, temporary slope drains should be designed by a qualified design professional. Plans and specifications should be referred to by field personnel throughout the construction process.

Site Preparation

Determine exact location of underground utilities.

Place temporary slope drain on undisturbed soil or well-compacted fill at locations and elevations shown on the plans.

Grade the diversion channel at the top of the slope toward the temporary slope drain according to the design plan. Provide positive grade in the pipe under the ridge.

Hand tamp the soil under and around the pipe in lifts not to exceed 6”.

Ensure that the fill over the drain pipe at the top of the slope is placed to the dimensions shown on the design plan.

Ensure that all slope drain connections are secure and watertight.

Ensure that all fill material is well-compacted. Securely anchor the exposed section of the drain according to the design.

Extend the drain beyond the toe of the slope and adequately protect the outlet from erosion.

Make the settled, compacted diversion ridge no less than 1 foot above the top of the pipe at every point.

Erosion Control

Compaction of earthfill around the pipe in the vicinity of the ridge is extremely important to avoid piping failure and blowouts.

Immediately stabilize all disturbed areas following construction according to the design plan (with vegetation or other appropriate means of protection).

Construction Verification

Verify that materials, elevations and installation procedures meet design specifications.

Joints should be carefully inspected for separations or looseness.

Common Problems

Consult with a qualified design professional if any of the following occur:

- Variations in topography on site indicate temporary slope drains will not function as intended.

- Pipe separates or is displaced.
- Animals are going into the pipe outlet.

Maintenance

Inspect slope drains and supporting diversions once a week and after every storm event.

Check the inlet for sediment or trash accumulation; clear and restore to proper condition.

Check the fill over the pipe for settlement, cracking or piping holes; repair immediately.

Check for holes where the pipe emerges from the ridge; repair immediately.

Check the conduit for evidence of leaks or inadequate anchoring; repair immediately.

Check the outlet for erosion or sedimentation; clean and repair, or extend if necessary.

Once slopes have been stabilized, remove the temporary diversions and slope drains so that runoff water no longer concentrates but flows uniformly over the protected slope. Stabilize the diversion and slope drain areas.

This Page Intentionally Left Blank

Brush/Fabric Barrier (BFB)



Practice Description

A brush/fabric barrier is a dam-like structure constructed from woody residue and faced with a non-woven geotextile fabric to provide a temporary sediment basin. This practice is applicable on sites with a small drainage area where brush and other woody debris are available from a clearing and grubbing operation.

Typical Components of the Practice

- Site Preparation
- Material Installation
- Construction Verification
- Maintenance

Construction

Prior to start of construction a qualified design professional should determine the location, and storage for the barrier. Typically, brush/fabric barriers are constructed where materials are readily available and at a location with adequate storage characteristics.

Site Preparation

The foundation for the barrier should be relatively smooth prior to placement of the cleared and grubbed material.

Material Installation

Place the cleared and grubbed material in a densely compacted row, mostly on the contour with each end upturned so that excessive flows will go over the top of the barrier and not around the ends of the barrier.

Densely packed material should be placed so that the main stems of the woody debris are aligned with the length of the barrier. Small stems and limbs protruding from the bundle that could damage the fabric should be trimmed.

Generally, the barrier should be at least 3 feet tall, but no more than 6 feet tall. The width of the barrier perpendicular to the direction of flow should be at least 5 feet at its base.

Geotextile filter fabric consistent with the fabric used for silt fencing can be used to cover the face of the barrier. It is best to use wide and long rolls of the fabric so that splicing is minimized or eliminated.

The fabric should be securely buried at the bottom of an excavated trench that is at least 6" deep in front of the barrier. Prior to backfilling the trench, the fabric should be securely staked at 3 foot centers with minimum 18" long wooden stakes.

Avoid longitudinal splices of the fabric. Vertical splices must be securely fastened to each other so that flows will not short circuit through the splice. The minimum vertical splice overlap should be 3 foot.

The top edge of the fabric should be secured so that it will not sag below the designed storage elevation. The upper edge can be anchored with twine fastened to the fabric and secured to stakes behind the barrier.

Construction Verification

Check finished size, elevation, storage, and shape for compliance with standard drawings and materials list (check for compliance with specifications if included in contract specifications).

Common Problems

Consult with a qualified design professional if any of the following occur:

- Variations in topography on site indicate brush/fabric barrier will not function as intended. Change in plan will be needed.

- There is not adequate cleared woody material to construct the barrier.
- Materials specified in the plan are not available.

Maintenance

Inspect the barrier for short-circuiting of water or flow around the ends of the barrier after each significant rainfall event.

Sediment should be removed if it reaches a depth of $\frac{1}{2}$ the original fabric height. If the area behind the barrier fills with sediment there is a greater likelihood that water will flow around the end of the barrier and cause the practice to fail.

Large rainfall events that overtop the structure can result in gully erosion behind the barrier. This should be repaired as needed.

Brush/fabric barriers are temporary structures and should be removed when their useful life has been completed. All accumulated sediment should be properly stabilized and the area where the barrier was located should be seeded and mulched immediately unless a different treatment is prescribed.

This Page Intentionally Left Blank

Filter Strip (FS)



Practice Description

A filter strip is a wide belt of vegetation designed to provide infiltration, intercept sediment and other pollutants, and reduce stormwater flow and velocity. Filter strips are similar to grassed swales except that they are designed to intercept overland sheet flow (not channel flow). They cannot treat high velocity flows. Surface runoff must be evenly distributed across the filter strip. This practice applies on construction sites and other disturbed areas.

Typical Components of the Practice

- Preservation and Protection of Existing Vegetation
- Site Preparation
- Applying Soil Amendments
- Planting
- Mulching
- Construction Verification
- Maintenance

Installation - preservation of existing vegetation

Prior to start of installation, filter strips should be designed by a qualified professional. Plans and specifications should be referred to by field personnel throughout the construction process.

Preserve vegetation on designated areas listed in plan and avoid surface disturbances that affect sheet flow of stormwater runoff.

At the start of development, fence off any undisturbed strips to be preserved.

Avoid storing debris from clearing and grubbing, and other construction waste material in strips during construction.

Installation-planting

Site Preparation

Prior to start of installation, filter strips should be designed by a qualified professional. Plans and specifications should be referred to by field personnel throughout the construction process. The filter strip should be installed according to planned alignment, grade and cross section.

If the upper area does not have a level edge, remove any obstructions and grade a level swale at the top edge of the filter strip. The swale should discharge to the filter strip along the level edge and serve as a level spreader to distribute runoff evenly to the filter strip.

Any rills and gullies over the filter strip area must be filled and smoothed to ensure that overland flow will discharge across the filter strip along a smooth surface.

Seedbed Preparation

Grade and loosen soil to a smooth firm surface to enhance rooting of seedlings and reduce rill erosion. If they exist, break up large clods and loosen compacted, hard or crusted soil surfaces with a disk, ripper, chisel, harrow or other tillage equipment. Avoid preparing the seedbed under excessively wet conditions.

For broadcast seeding and drilling, tillage should adequately loosen the soil to a depth of at least 6", alleviate compaction, and smooth and firm the soil for the proper placement of seed.

For no-till drilling, the soil surface does not need to be loosened unless the site has surface compaction. If shallow compaction exists, the area should be chiseled across the slope to a depth of at least 6". If compaction exists between 6" and 12" the area should be chiseled or subsoiled at least 12".

Applying Soil Amendments

Liming

Follow the design plan or soil test recommendation. If a plan or soil test is not available, use 2 tons/acre of ground agricultural lime on clayey soils (approximately 90 lbs/1000 ft²) and 1 ton/acre on sandy soils (approximately 45 lbs/1000 ft²). Exception: If the cover is tall fescue and clover, use the 2 tons/acre rate (90 lbs/1000 ft²) on both clayey and sandy soils.

Spread the specified amount of lime and incorporate into the top 6" of soil after applying fertilizer.

Fertilizing

Apply a complete fertilizer at rates specified in the design plan or soil test recommended. In the absence of soil tests, use the following as a guide: Grass alone: 8-24-24 or equivalent – 400 lbs/acre (9.2 lbs/1000 ft²). When vegetation has emerged to a stand and is growing, 30 to 40 lbs/acre (0.8 lb/1000 ft²) of additional nitrogen fertilizer should be applied.

Grass – Legume Mixture: 8-24-24 or equivalent – 400 lbs/acre (9.2 lbs/1000 ft²). When vegetation has emerged to a stand and is growing, 30 to 40 lbs (0.8 lb/1000 ft²) of additional nitrogen fertilizer should be applied.

Legume alone: 0-20-20 or equivalent – 500 lbs/acre (11.5 lbs/1000 ft²).

Note: Fertilizer can be blended to meet exact fertilizer recommendations. Take soil test recommendations to local fertilizer dealer for bulk fertilizer blends. This may be more economical than bagged fertilizer.

Incorporate lime and fertilizer to a minimum depth of at least 6" or more by disking or chiseling on slopes of up to 3:1.

Planting

Plant the species specified in the plan at the rate and depth specified. In the absence of plans and specifications, plant species and seeding rates may be selected by qualified persons using Figure FS-1 and Table FS-1.

Apply seed uniformly using a cyclone seeder, drill seeder, cultipacker seeder or hydroseeder.

When using a drill seeder, plant grasses and legumes ¼" to ½" deep. Calibrate equipment in the field.

When planting by methods other than a drill seeder, cover seed by raking, or dragging a chain, brush or mat. Then firm the soil lightly with a roller. Seed can also be covered with hydro-mulched wood fiber and tackifier. Legumes require inoculation with nitrogen-fixing bacteria to ensure good growth. Purchase inoculum specific for the seed and mix with seed prior to planting.

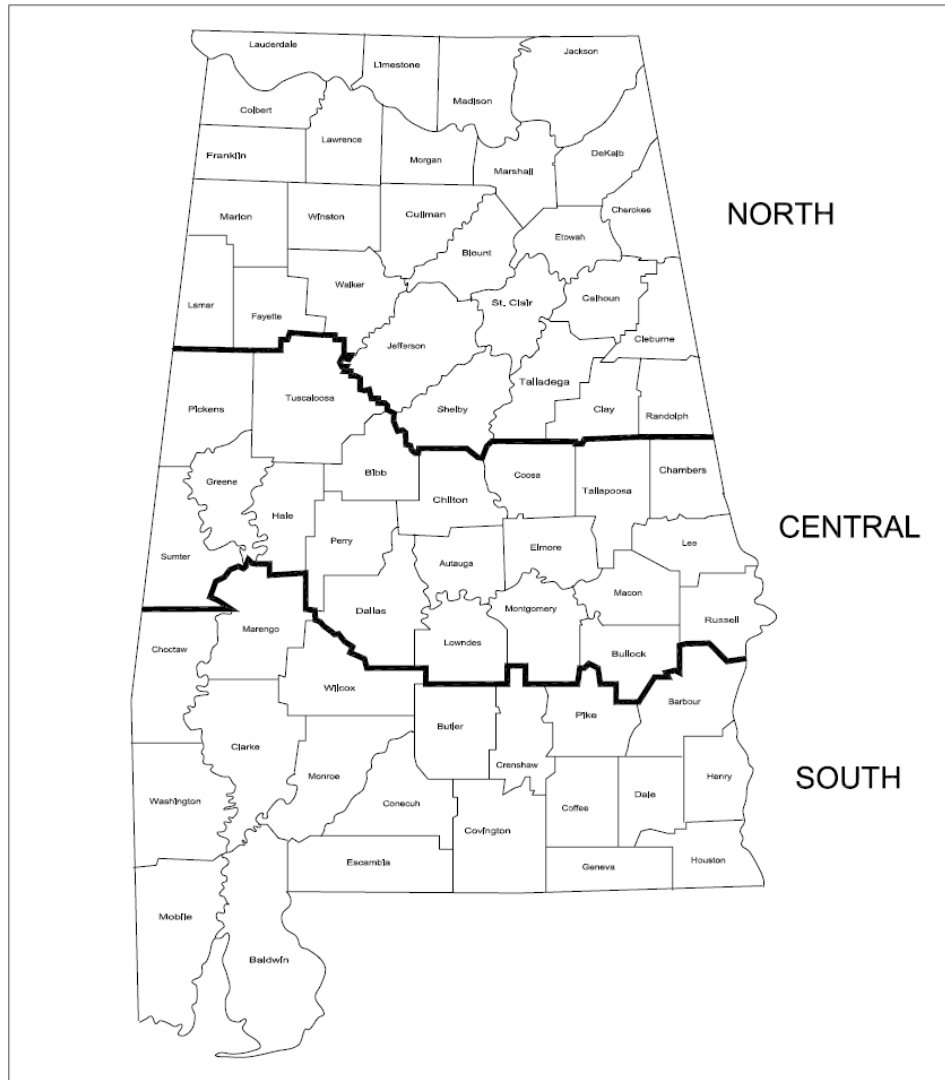

Figure FS-1 Geographical Areas for Species Adaptation

Note: Site conditions related to soils and aspect in counties adjacent or close to county boundaries may justify adjustments in planting dates by qualified design professionals.

Mulching

Cover approximately 75% of the surface with the specified mulch materials. Crimp, tack or tie down straw mulch with netting. Mulching is extremely important for successful seeding (*See Mulching practice for more details*).

Table FS-1 Commonly Used Plants for Permanent Cover with Rates and Dates¹

Species	Seeding Rates/Ac PLS ²	North	Central	South
		Seeding Dates		
Bahiagrass, Pensacola	40 lbs	--	Mar 1-July 1	Feb 1-Nov 1 ³
Bermudagrass, Common	10 lbs	Apr 1-July 1	Mar 15-July 15	Mar 1-July 15
Bahiagrass, Pensacola Bermudagrass, Common	30 lbs 5 lbs	--	Mar 1-July 1	Mar 1-July 15
Bermudagrass, Hybrid (Lawn Types)	Solid Sod	Anytime	Anytime	Anytime
Bermudagrass, Hybrid (Lawn Types)	Sprigs 1/sq ft	Mar 1-Aug 1	Mar 1-Aug 1	Feb 15 - Sep 1
Fescue, Tall	40-50 lbs	Sep 1-Nov 1	Sep 1-Nov 1	--
Sericea	40-60 lbs	Mar 15-July 15	Mar 1-July 15	Feb 15 -July 15
Sericea & Common Bermudagrass	40 lbs 10 lbs	Mar 15-July 15	Mar 1-July 15	Feb 15-July 15
Switchgrass, Alamo	4 lbs	Apr 1-Jun 15	Mar 15-Jun 15	Mar 15-Jun 15

1. DO NOT USE Seeding Rates as part of a mixture unless shown as a mixture in this table
2. PLS means pure live seed and is used to adjust seeding rates. For example, to plant 10 lbs of a species with germination of 80% and with purity of 90%, $PLS = 0.8 \times 0.9 = 72\%$, $10 PLS = 10/0.72 = 13.9$ lbs.
3. A late fall planting of Bahia should contain 45 lbs/Ac of small grain to provide cover during winter months.

Construction Verification

Check materials and installation for compliance with specifications during installation of products.

Common Problems

Consult with a qualified professional if the following occurs:

- Variations in topography on site indicate filter strip will not function as intended.
- Design specifications for seed variety, seeding dates or mulching cannot be met; substitutions may be required. Unapproved substitutions could lead to failure.
- Seeding at the wrong time of the year results in an inadequate stand. Reseed according to specifications of a qualified professional.

- Inadequate mulching results in an inadequate stand, bare spots or eroded areas; prepare seedbed, reseed, cover seed evenly and tack or tie down mulch, especially on slopes, ridges and in channels (see recommendations under Maintenance).

Maintenance

Erosion

Check for eroded channels in the filter strip after every storm event until the vegetation is well established. Eroded areas should be repaired by filling and/or smoothing, and reapplication of lime, fertilizer, seed and mulch. It is particularly important that the surface is smooth and promotes sheet flow of storm runoff. Generally, a stand of vegetation cannot be determined to be fully established until vegetative cover has been maintained for at least 1 year after planting.

Reseeding

Inspect seeding monthly for stand survival and vigor.

If stand is inadequate identify the cause of failure – choice of plant materials, lime and fertilizer quantities, poor seedbed preparation or weather – and take corrective action. If vegetation fails to grow, have the soil tested to determine whether pH is in the correct range or nutrient deficiency is a problem.

Stand conditions, particularly percent coverage, will determine the extent of remedial actions such as seedbed preparation and reseeding. A qualified professional should be consulted to advise on remedial actions. Consider drill seeding if enough residue exists.

Fertilizing

Establishment may require refertilizing the stand in the second growing season. Follow soil test recommendations or the specifications provided for establishment.

Mowing

Mow vegetation to prevent woody plants from invading.

Certain species can be weakened by mowing regimes that significantly reduce their food reserves stored for the next growing season: fescue should not be mowed closer than 4” during the summer; sericea should not be mowed closer than 4” during the growing season and it should not be mowed at all between late summer and frost.

Bermuda grass and bahiagrass are tolerant of most mowing regimes and can be mowed often and close, if so desired, during their growing season.

Floating Turbidity Barrier (FB)



Practice Description

A floating turbidity barrier consists of geotextile material (curtain) with floats on the top, weights on the bottom, and an anchorage system that minimizes sediment transport from a disturbed area that is adjacent to or within a body of water. The barrier provides sedimentation and turbidity protection for a watercourse from up-slope land disturbance activities where conventional erosion and sediment controls cannot be used or need supplemental control, or from dredging or filling operations within a watercourse. The practice can be used in non-tidal and tidal watercourses where intrusion into the watercourse by construction activities has been permitted and subsequent sediment movement is unavoidable.

Typical Components of the Practice

- Site Preparation
- Material Installation
- Construction Verification
- Removal
- Maintenance

Construction

Prior to the start of construction, a qualified professional should determine the type of barrier to be used, location, and installation procedures for the barrier.

Site Preparation

If a floating turbidity barrier is specified in the erosion and sediment control plan, it should be installed before any land disturbing activities. Shoreline anchor points should be located according to the plans.

Material Installation

When installing Type I barrier in the calm water of lakes or ponds it is usually sufficient to merely set the curtain end stakes or anchor points (using anchor buoys if bottom anchors are employed), then tow the curtain in the furled condition out and attach it to these stakes or anchor points. Following this, any additional stakes or buoyed anchors required to maintain the desired location of the curtain may be set and these anchor points made fast to the curtain. Only then, the furling lines should be cut to let the curtain skirt drop.

When installing Type II or III barriers in rivers or in other moving water it is important to set all the curtain anchor points. Care must be taken to ensure that anchor points are of sufficient holding power to retain the curtain under the expected current conditions, before putting the furled curtain into the water. Anchor buoys should be employed on all anchors to prevent the current from submerging the flotation at the anchor points. If the moving water into which the curtain is being installed is tidal and will subject the curtain to currents in both directions as the tide changes, it is important to provide anchors on both sides of the curtain for 2 reasons:

- Curtain movement will be minimized during tidal current reversals.
- The curtain will not overrun the anchors pulling them out when the tide reverses.

When the anchors are secure, the furled curtain should be secured to the upstream anchor point and then sequentially attached to each next downstream anchor point until the entire curtain is in position. At this point, and before unfurling, the “lay” of the curtain should be assessed and any necessary adjustments made to the anchors. Finally, when the location is ascertained to be as desired the furling lines should be cut to allow the skirt to drop.

The anchoring line attached to the flotation device on the downstream side will provide support for the curtain. Attaching the anchors to the bottom of the curtain could cause premature failure of the curtain due to the stresses imparted on the middle section of the curtain.

Construction Verification

Check the type of floating turbidity barrier, installation location, and the installation and anchorage procedures for compliance with the standard drawings and materials list (check for compliance with specifications if included in contract specifications).

Removal

Care should be taken to protect the skirt from damage as the turbidity curtain is dragged from the water.

The site selected to bring the curtain ashore should be free of sharp rocks, broken cement, debris, etc. so as to minimize damage when hauling the curtain over the area.

If the curtain has a deep skirt, it can be further protected by running a small boat along its length with a crew installing furling lines before attempting to remove the curtain from the water.

Common Problems

Consult with a qualified design professional if any of the following occur:

- Variations in topography on site indicate that a floating turbidity barrier will not function as intended. Change in plan will be needed.
- The specified anchorage system will not function as planned.
- Turbid water is escaping from the barrier enclosure.
- Materials specified in the plan are not available.

Maintenance

The floating turbidity barrier should be maintained for the duration of the project to ensure the continuous protection of the watercourse. Anchors, anchor lines and buoys must be regularly checked to remove debris.

If repairs to the geotextile fabric become necessary, there are normally repair kits available from the manufacturer. Follow the manufacturer's instructions to ensure the adequacy of the repair.

When the curtain is no longer required as determined by the responsible individual, the curtain and related components should be removed in such a manner as to minimize turbidity. If required by the contract or the responsible individual, sediment should be removed, and the original depth (or plan elevation) restored before removing the curtain. Remaining sediment should be sufficiently settled before removing the curtain. Any spoils should be taken to an upland area and stabilized.

This Page Intentionally Left Blank

Flocculant (FL)

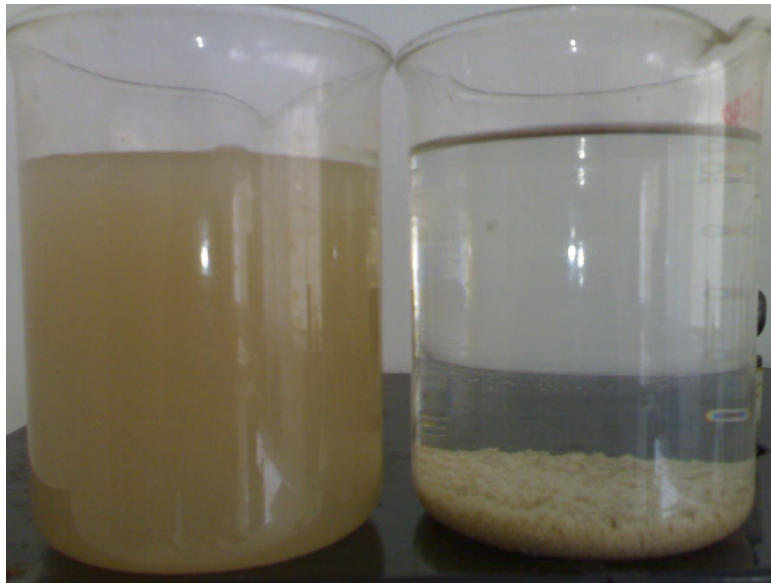

Practice Description

A Flocculant is a chemical that facilitates the aggregation of fine suspended soil particles to produce large flocs that can quickly settle out of suspension. Flocculants are often used to help polish or minimize turbidity of stormwater runoff from construction sites.

Typical Components of the Practice

- Site Preparation
- Flocculant Application
- Installation Verification
- Maintenance

Application

Prior to the start of construction, the application of flocculants should be designed by a qualified design professional and plans and specifications should be available to field personnel.

The application should conform to the design and specifications provided in the plans.

Site Preparation

Prepare the site following design and specifications. Ensure that all erosion control practices are installed and properly functioning upstream of the flocculant application site.

Flocculant Application

Ensure that only the approved flocculant for the job is used, and only at the dosage rates and application methods approved.

The Material Safety Data Sheet for the approved flocculant should be available on the job site. Flocculants should be mixed and/or applied in accordance with all Occupational Safety and Health Administration (OSHA) Material Safety Data Sheet requirements and the manufacturer's recommendations for the specified use conforming to all federal, state and local laws, rules and regulations.

Solid form of flocculant (logs) should be installed at a location that maintains hydration and shade. It should not be placed in sediment, but should be located in turbulent flow to promote mixing.

Dry form (powder) may be applied by hand spreader or a mechanical spreader. For small applications it can be applied by hand.

Do not apply flocculants directly to streams, wetlands, or other waters of the state. If near a water body, observe the identified Buffer Zone for the job.

All flocculant applications must drain into a sediment basin or other BMP that promotes settling for final flocculation prior to discharge from the site.

Flocculants used in conjunction with a sediment basin should be introduced upstream of the basin in a turbulent flow area to ensure proper mixing.

Installation Verification

Check all components of the practice during installation to ensure that specifications are being met.

Common Problems

Consult with a qualified design professional if any of the following occur:

- Application specifications for flocculants cannot be met; alternatives may be required. Unapproved application techniques could lead to failure.
- Visible turbidity occurs after application.

Maintenance

An operation and maintenance plan must be prepared for use by the operator responsible for flocculant application. Plan items should include the following items:

- Reapply flocculants at specified intervals or when turbidity control is no longer effective.
- Inspect flocculant logs to ensure they are properly located and hydrated.
- Deposition of sediment in sediment basins and other sediment catching BMPs may require periodic sediment removal to maintain normal functions of sediment control practices.

This Page Intentionally Left Blank

Inlet Protection (IP)



Practice Description

Inlet protection is a temporary practice installed around, above, or within a storm drain to minimize the conveyance of sediment. This practice applies where early use of the storm drain system is necessary prior to stabilization of the disturbed drainage area.

Typical Components of the Practice

- Site Preparation
- Geotextile Installation
- Structure Installation
- Grading
- Stabilization
- Construction Verification
- Maintenance

Installation

Prior to start of construction, inlet protection structures should be designed by a qualified professional. Plans and specifications should be available to field personnel.

Site Preparation

The soil around the drop inlet should be well compacted. The area around the drop inlet should be shaped, if necessary, to store the runoff on an almost level area. If runoff could bypass the protected inlet, a temporary dike should be planned and force the runoff to be trapped by the protective device.

Geotextile Installation

An 8 oz. non-woven geotextile is used as an underlayment prior to the structure placement. The geotextile should extend from the stormwater inlet to the required distance in front of the structure. The geotextile underlayment should be securely fastened to the compacted soil with staples to prevent undermining.

Structure Installation

The structure can be constructed of silt fencing materials, concrete blocks and gravel, sand bags, wattles, or premanufactured devices. The structures should be structurally sound to prevent buckling, sagging, or undermining. Check to ensure the following installation practices are followed:

Silt Fence Inlet Protection

- Use geotextile underlayment on the compacted earth surface from the inlet to at least 1 ft. beyond the silt fence. The geotextile must be securely pinned at 5-inch centers at the inlet and around the outside edge of the geotextile.
- Use steel T-posts on maximum 3 ft. centers around the inlet.
- Do not trench the silt fence. Install the wire backing tightly from the compacted earth surface to the top of the posts, and secure to the posts.
- Add 2 x 4 bracing at the top of the posts and diagonally across the corners. Drill holes to fit over T-posts once T-posts are installed to ensure a proper fit.
- Install a dewatering device to remove water from the impoundment within 48 hours. A 2 x 4 vertical board with graduated holes (smallest at bottom and largest at top) has been found to work well. The fabric should be secured to the board with staples and the geotextile punctured at each hole.
- Install the geotextile (4 oz. non-woven) Type A silt fence. The top of the geotextile shall be folded over the 2 x 4 bracing and stapled. The bottom of the geotextile shall extend about 8 inches horizontally from the bottom of the fence and secured with pins every 5 inches. The bottom of the fabric at the corners shall be cut and pinned securely to prevent water undermining. Attach the geotextile to the wire as normally done for a silt fence.



Figure IP-1 Silt Fence Inlet Protection Installation. (Showing silt fence, geotextile underlayment, steel T-posts, 2 x 4 bracing, and dewatering device.)
(Photo courtesy of AU-SRF. See Appendix for CAD files)

Block and Gravel Inlet Protection

- Use geotextile underlayment on the compacted earth surface that extends from the inlet, under the blocks and at least 1 ft. beyond the blocks, and securely pinned at 5 inches centers at the inlet and around the outside edge of the geotextile. A second underlay that extends from the inlet, under the blocks, and to the top of the blocks between the blocks and gravel. Note: place geotextile vertically on the blocks surface after blocks and hardware cloth are installed.
- Use 8-inch cinder blocks no more than two blocks high. Stacked the second layer of blocks in a staggered fashion. All blocks are placed in a normal orientation with at least one block turned sideways for dewatering.
- The dewatering block(s) shall be at the lowest elevation, faced with hardware cloth, and the geotextile cut out in a three-inch-tall rectangular section for dewatering.
- Place aggregate (ALDOT no. 4 stone) in a triangular cross-section to the top of the blocks with the aggregate extending out 1 ft. at the top from the blocks before sloping down at a 1:1 ft./ft. slope.



Figure IP-2 Block and Gravel Inlet Protection Installation.
(Showing geotextile underlayment, gravel, and dewatering device.)
(Photo courtesy of AU-SRF. See Appendix for CAD files)



Figure IP-3 Block and Gravel Inlet Protection Installation.
(Showing dewatering device.)
(Photo courtesy of AU-SRF. See Appendix for CAD files)

Sand Bag Inlet Protection

- Use geotextile underlayment on the compacted earth surface that extends from the inlet to at least 1 ft. beyond the sand bags. Pin the geotextile securely at the inlet and around the edges on 5-inch centers.
- Place sand bags tight against each other around an inlet in a circular fashion with at least a 1 ft. space between the bags and the inlet.
- Orient the three layers of bags into a triangular cross-section with the first layer consisting of two bags oriented tangent to the circle, the second layer consisting of one bag perpendicular to the circle, and the third layer consisting of one bag tangent to the circle.



Figure IP-4 Sand Bag Inlet Protection Installation.

(Photo courtesy of AU-SRF. See Appendix for CAD files)

Wattle Inlet Protection

- Use geotextile underlayment on the compacted earth surface that extends from the inlet to at least 1 ft. beyond the wattles. Pin the geotextile securely at the inlet and around the edges on 5-inch centers.
- Use a wattle that is denser and less porous to ensure ponding occurs.
- Place the wattle in a circular fashion at least 1 ft. from the inlet. Wattle ends should be overlapped at least 18 inches and secured with grade stakes or hardwood stakes a T-Pee or A-Frame type installation method.
- Stake the wattles with T-Pee stakes at least 2 ft. on centers.
- Prevent the wattles from floating by securing with sod staples on each side of the wattle on approximate 6-inch centers.



Figure IP-5 Wattle Inlet Protection Installation.
(Photo courtesy of AU-SRF. See Appendix for CAD files)

Premanufactured Inlet Protection Structures

Premanufactured inlet protective structures should be installed and maintained according to the manufacturer's requirements.

As a minimum, insure that the premanufactured inlet protection structure accomplishes the following:

- Is structurally supported to withstand sediment and hydrostatic loads.
- Ponds water to allow for coarse sediment to settle out of suspension.
- Does not float or undermine.
- Does not cause erosion of the soil surface between the device and the inlet.
- Has a dewatering mechanism to prevent prolonged flooding.

Grading

If needed to prevent bypass flow or ensure adequate storage, construct a temporary dike on the down slope side of the structure. Material from within the sediment pool may be used for dike construction. To be effective, the site must create the specified volume of ponding around the fabric structure.

Stabilization

Stabilize all bare areas that drain to the inlet with temporary seeding and mulching unless construction will disturb it within 13 days.

Construction Verification

Check finished grades and dimensions of fabric drop inlet protection structures.

Common Problems

Consult with a qualified design professional if any of the following occur:

- Variations in site conditions indicate that the practice will not function as intended; change in plan may be needed.
- Sediment not removed from pool resulting in inadequate storage volume for the next storm.
- Top of structure is too high; resulting in flow bypassing the inlet.
- Geotextile underlayment is not adjacent to the inlet exterior surface; resulting in erosion and undercutting of the structure.

Maintenance

Inspect fabric barrier after each rainfall event and make needed repairs immediately.

Remove sediment from the pool area when sediment has reached $\frac{1}{2}$ the fabric height. Take care not to damage or undercut the fabric during the sediment removal.

When the contributing drainage area has been adequately stabilized, remove all materials and unstable sediment and dispose of properly. Fill the disturbed area to the grade of the drop inlet. Stabilize disturbed areas in accordance with the plans.

This Page Intentionally Left Blank

Rock Filter Dam (RD)



Practice Description

A rock filter dam is a stone embankment designed to help capture sediment in natural or constructed drainageways on construction sites. This practice can be used as a forebay to a sediment basin to help capture coarser particles of sediment.

Typical Components of the Practice

- Site Preparation
- Rock Placement
- Erosion and Sediment Control
- Construction Verification
- Maintenance

Construction

Prior to start of construction, rock dams should be designed by a qualified design professional. The rock filter dam plan should include details on dam height, dam top width, dam side slopes, rock size(s), and geotextile requirements. Plans and specifications should be referred to by field personnel throughout the construction process.

Site Preparation

Determine exact location of underground utilities and avoid construction over and under utilities.

Clear and grub the area under the dam, removing and properly disposing of all root material, brush and other debris.

Divert runoff from undisturbed areas away from the rock dam and basin area. Smooth the dam foundation.

If specified, cover the foundation with geotextile fabric, making sure the upstream strips overlap the downstream strips at least 1 foot and the upslope end is embedded into the foundation at least 1 foot.

Rock Placement

Construct the dam by placing well graded, hard, angular, durable rock of the specified size over the foundation to planned dimensions and securely embed into both channel banks. Place geotextile and smaller “choking” stone on the upstream face if specified.

Once the dam is in place, clear the sediment basin area and dispose of the cleared material.

Set a marker stake to indicate the clean out elevation (i.e., point at which the basin is 50% full of sediment).

Erosion and Sediment Control

Stabilize all disturbed areas with either Temporary or Permanent Seeding.

Construction Verification

Check materials and finished elevations of the rock filter dam for compliance with specifications.

Common Problems

Consult with qualified design professional if the following occurs:

- Variations in topography on-site indicate rock filter dam will not function as intended; changes in plan may be needed.
- Materials specified in the plan are not available.

Maintenance

Inspect the rock dam and basin after each storm event.

Check the dam for rock displacement and abutments for erosion and repair immediately when needed. If rock size appears too small or embankment slope is too steep, replace stone with larger size or reduce slope.

Check the drainage way at toe of dam for erosion. If erosion is occurring, a repair involving geotextile fabric (including another toe-in) and additional rock are probably needed to establish a stable outlet.

Remove sediment from the pond reservoir area when it accumulates to $\frac{1}{2}$ the design volume. If the basin does not drain between storms because the filter (choking) stone (small gravel) and/or geotextile on the upstream face have become clogged, the filter system should be replaced.

Once the construction site is permanently stabilized, remove the structure and any unstable sediment. Smooth the basin site to blend with the surrounding area and stabilize. Sediment should be placed in designated disposal areas and stabilized.

This Page Intentionally Left Blank

Sediment Barrier (SB)



Practice Description

A sediment barrier is a temporary sediment control practice installed downstream of a disturbed area intended to remove large-sized suspended sediment from sheet flow runoff by facilitating settling and to a lesser extent filtration. The most commonly used sediment barrier is a silt fence made up of a geotextile fabric that is anchored into the ground and attached to supporting posts and possibly reinforced with a wire fence or polypropylene netting. Other barrier materials could include sand bags, wattles, and various man-made materials and devices that can be used in a similar manner as a silt fence.

This practice applies downstream of small disturbed areas that yield runoff volumes less than the design storage volume. Barriers intercept runoff from upslope to form impoundments that temporarily detain runoff and allow sediment to settle out of the water and remain on the construction site.

Typical Components of the Practice

- Site Preparation
- Installation
- Erosion Control
- Construction Verification
- Maintenance

Construction

Prior to start of construction, sediment barriers should be designed by a qualified professional. Plans and specifications should be referred to by field personnel throughout the construction process.

Note: Silt fence is the only barrier installation being covered in this handbook.

Site Preparation

Determine exact location of underground utilities so that locations for digging or placement of stakes can be selected where utilities will not be damaged.

Smooth the construction zone to provide a broad, nearly level area for the fence. The area should be wide enough throughout the length of the fence to provide storage of runoff and sediment behind the fence.

Silt Fence Installation

Fence should be installed generally on the contour with each end turned upslope, in “C” configurations, or “J” hooks, so that runoff can be intercepted as sheet flow. Ends should be flared uphill to provide temporary storage of water. Fence should be placed so that runoff from disturbed areas must pass through the fence. Fence should not be placed across concentrated flow areas such as channels or waterways unless specifically designed as a temporary check dam. When placed near the toe of a slope, the fence should be installed far enough from the slope toe to provide a broad flat area for adequate storage capacity for sediment. An off-set installation with a trench or slice is now the preferred method of installation. Dig a trench or make a slice at least 6” deep along the fence alignment as shown in Figures SB-1 and SB-3 for Types A & B fences.

Drive posts to the depth specified 6 inches downslope of the trench. Space posts a maximum of 10 feet for Type A fencing, or 6 feet for Type B fencing. In areas where water is ponded, the fence posts may be specified at half the spacing.

For Type A fence, fasten support wire fence to upslope side of posts, extending to the ground surface as shown in the Figure SB-1.

Attach continuous length of fabric to upslope side of fence posts and through the trench. Minimize the number of joints. Type A fence joints should be installed according to Figure SB-2. Type B fence should be joined by rolling the ends together using the “roll joint” method illustrated in Figure SB-4 or as detailed in the specifications. Avoid joints at low points in the fence line. When specified, install the overflow/dewatering device and splash pad at the low point in the fence.

Install tie backs as specified on the ends of the silt fence.

Backfill the trench with compacted earth as shown in Figures SB-1 and 3.

Provide good access in areas of heavy sedimentation for clean out and maintenance.

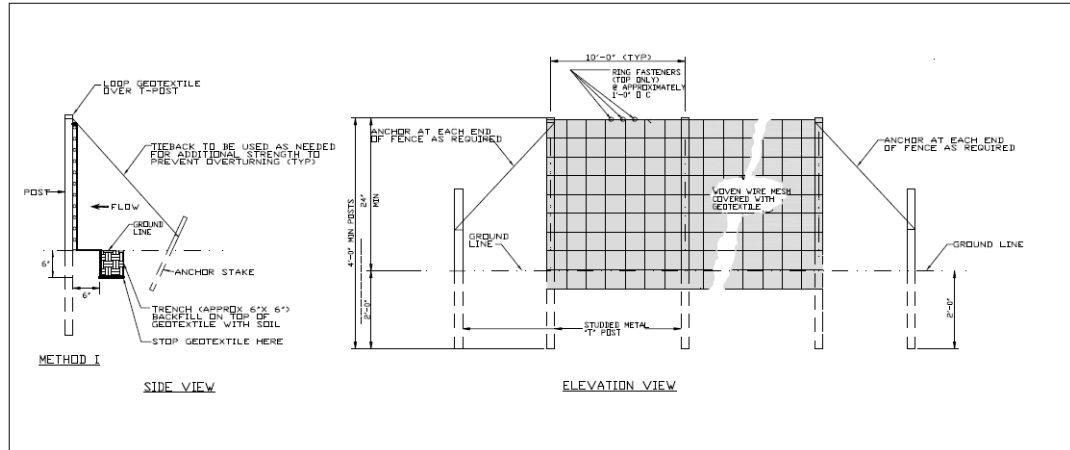

Figure SB-1 Silt Fence - Type A
(For post material requirements see Tables SB-2 and SB-3 (Volume I of Handbook))

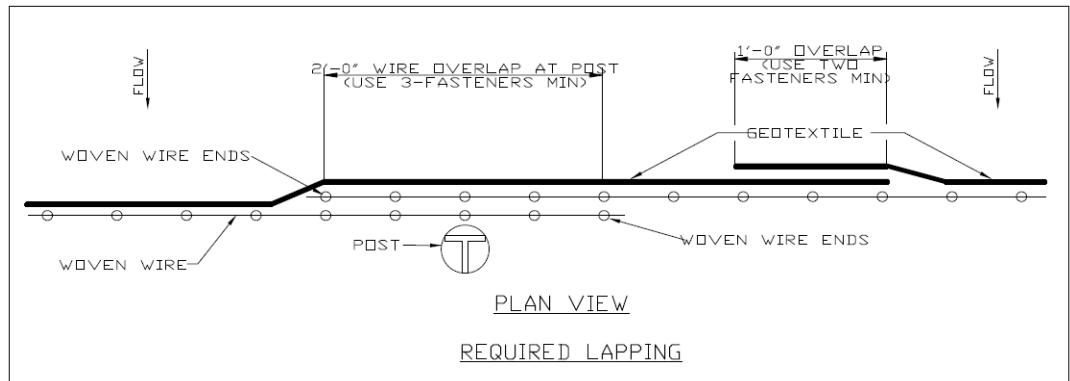

Figure SB-2 Type A Silt Fence Overlap

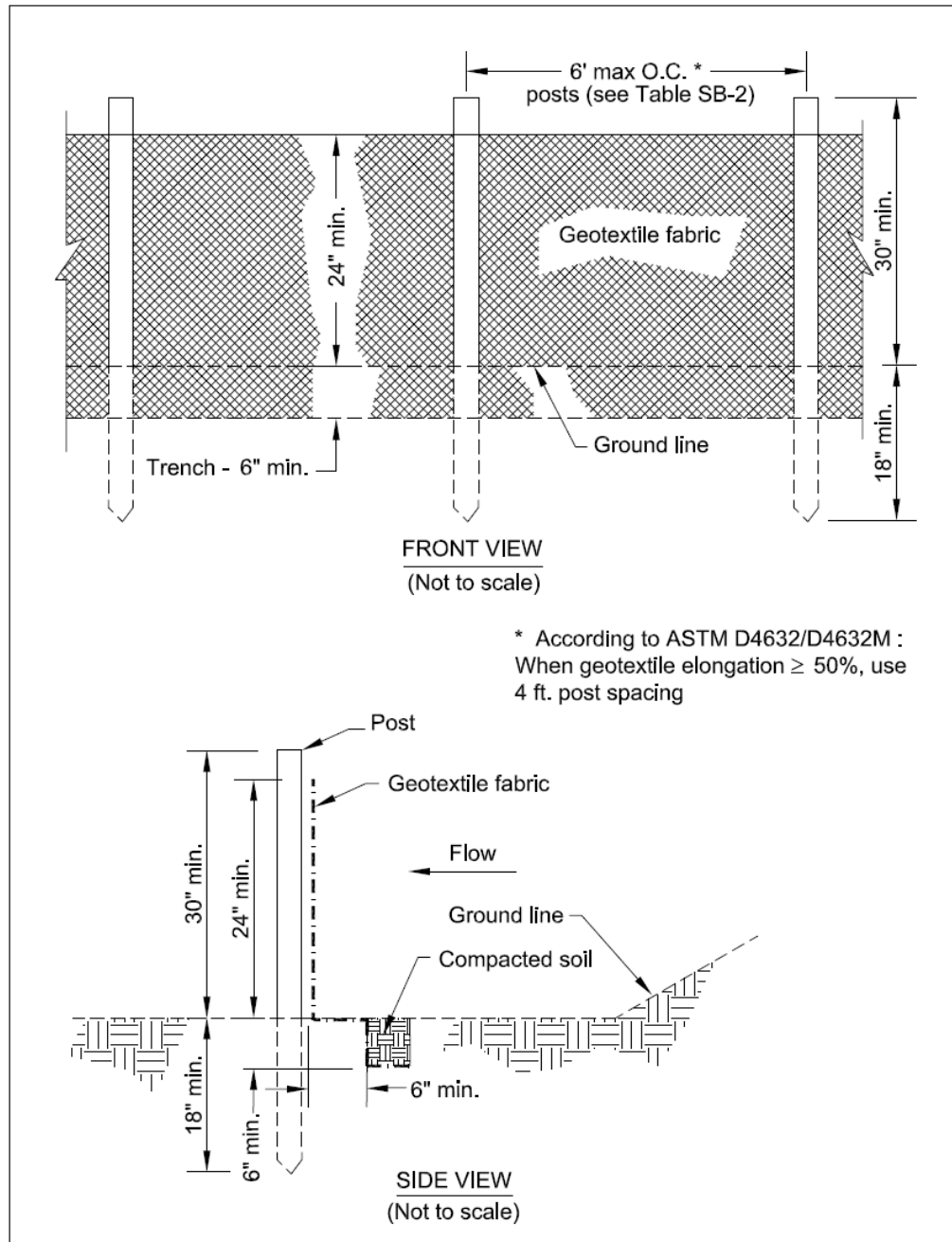

Figure SB-3 Silt Fence - Type B
(For post material requirements see Tables SB-2 and SB-3 (Volume I of Handbook))

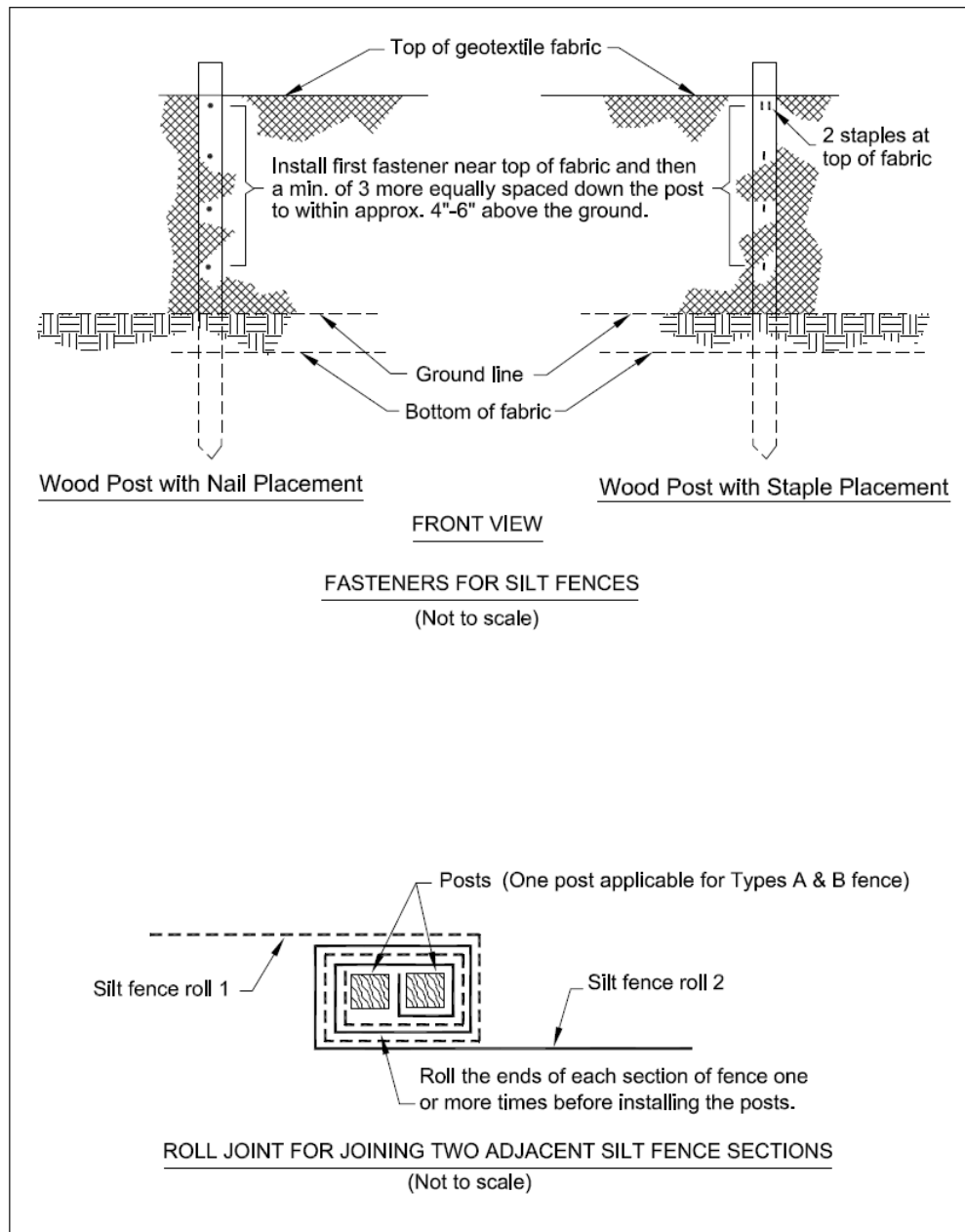

Figure SB-4 Type B Silt Fence Installation Details

Erosion Control

Stabilize disturbed areas in accordance with vegetation plan. If no vegetation plan exists, consider planting and mulching as a part of barrier installation and select planting information from appropriate planting practice, Permanent Seeding or Temporary Seeding. Select mulching information from the Mulching practice.

Construction Verification

Check finished grades and dimensions of the sediment fence. Check materials for compliance with specifications.

Common Problems

Consult with a qualified design professional if any of the following occur:

- Variations in topography onsite indicate sediment fence will not function as intended or alignment is not on contour or fence crosses concentrated flow areas; changes in plan may be needed.
- Design specifications for filter fabric, support posts, support fence, gravel or riprap cannot be met; substitutions may be required. Unapproved substitutions could lead to failure.
- Drainage area appears to exceed $\frac{1}{4}$ acre for 100 feet of non-reinforced silt fence and $\frac{1}{2}$ acre for reinforced fence.
- The runoff exceeds the storage volume of the silt fence.

Maintenance

Inspect silt fences at least once a week and after each significant rain event.

Make required repairs immediately.

Should the fabric of silt fence collapse, tear, decompose or become ineffective, replace it promptly.

Remove sediment deposits when they reach a depth of $\frac{1}{2}$ the height of the fence as installed to provide adequate storage volume for the next rain and to reduce pressure on the fence.

After the contributing drainage area has been properly stabilized, remove all barrier materials and unstable sediment deposits, bring the area to grade and stabilize it with vegetation.

Sediment Basin (SBN)



Practice Description

A temporary impoundment designed and constructed to capture stormwater runoff and soil particles. This practice applies to sites where more storage is needed than provided by other sediment control practices and where turbidity must be reduced.

Typical Components of the Practice

- Site Preparation
- Keyway Trench
- Skimmer or Surface Dewatering Device
- Embankment
- Emergency Spillway
- Basin and Baffles
- Erosion Control
- Flocculant
- Safety
- Construction Verification
- Maintenance

Construction

Prior to the start of construction, sediment basins should be designed by a qualified design professional.

Plans and specifications should be referred to by field personnel throughout the construction process. The sediment basin should be built according to planned grades and dimensions. Follow all federal, state and local requirements on impoundments.

Consider the following guidance as construction proceeds.

Site Preparation

Locate all utilities at the site to ensure avoidance.

Clear, grub and strip the dam foundation and emergency spillway area, removing all woody vegetation, rocks and other objectionable material. Dispose of trees, limbs, logs and other debris in designated disposal areas.

Stockpile surface soil for use later during topsoiling.

Delay clearing the pool area until the dam is complete and then remove brush, trees, and other objectionable materials to facilitate sediment cleanout.

Specified sumps or fore bays used to capture coarse grain sediment should be installed immediately upstream of the sediment basin and completed the same time as the sediment basin.

Keyway Trench

When specified, excavate the keyway trench along the centerline of the planned embankment to a depth determined by the qualified design professional (at least 2 feet). The trench bottom elevation should extend up both abutments to the riser crest elevation and have a bottom width of at least 8 feet and have side slopes no steeper than 1.5:1. Compaction requirements will be the same as those for the embankment.

Skimmer

Following are installation guidelines for a skimmer only:

Prevent the skimming device from settling into the mud by excavating a shallow pit under the skimmer or providing a low support under the skimmer of stone or timber (Figure SBN-1).

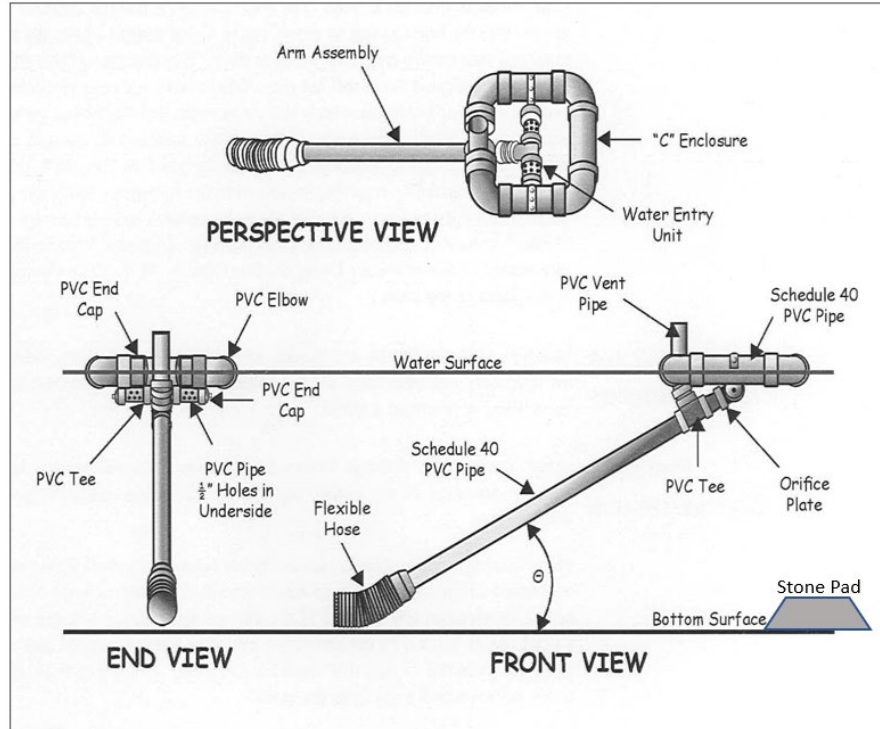

Figure SBN-1 Schematic of a skimmer.

(Modified from Pennsylvania Erosion and Sediment Pollution Control Manual, March 2000)

Place the barrel pipe (typically the same size as the skimmer arm) that goes through the embankment at the standing pool elevation on a firm, smooth foundation of impervious soil. Do not use pervious material such as sand, gravel, or crushed stone as backfill around the pipe. Place the fill material around the pipe in 4-inch layers and manually compact it under and around the pipe to at least the same density as the adjacent embankment. Care must be taken not to raise the pipe from the firm contact with its foundation when compacting under the pipe haunches.

Construct the anti-seep collar(s) if shown on the plans.

Place a minimum depth of 2 feet of compacted backfill over the pipe before crossing it with construction equipment. In no case should the pipe conduit be installed by cutting a trench through the dam after the embankment is complete.

Assemble the skimmer following the manufacturer's instructions, or as designed.

Lay the assembled skimmer on the bottom of the basin with the flexible joint at the inlet of the barrel pipe. Ensure the schedule 40 connecting pipe is at least 1.5 times the depth the skimmer should operate. Attach the flexible joint to the barrel pipe and position the skimmer over the excavated pit or support. Be sure to attach a rope to the skimmer and anchor it to the side of the basin. This will be used to pull the skimmer to the side for maintenance.

Install outlet protection as specified.

Embankment

Scarify the foundation of the dam before placing fill.

Use fill from predetermined borrow areas. It should be clean, stable soil free of roots, woody vegetation, rocks and other debris; and must be wet enough to form a ball without crumbling, yet not so wet that water can be squeezed out.

Place the most permeable soil in the downstream toe and the least permeable in the center portion of the dam.

Place the fill material in 6" to 9" continuous uncompacted layers over the length of the dam. Fill should then be compacted to a 4" to 6" thick continuous layer (One way is by routing construction equipment over the dam so that each layer is traversed by at least 4 passes of the equipment).

Protect the barrel pipe through the embankment with 2 feet of fill that has been compacted with hand tampers before traversing over the pipe with equipment.

Construct and compact the dam to an elevation 10% above the design height to allow for settling. The embankment generally has a minimum 8 ft. top width and 2.5:1 side slopes, but the design may specify a different top width and gentler side slopes.

Place a reference stake at the sediment clean out elevation shown on the plans (50% of design storage volume).

Emergency Spillway

Construct the spillway at the site located by a qualified design professional according to the plan design (in undisturbed soil around one end of the embankment, and so that any flow will return to the receiving channel without damaging the embankment).

Basin and Baffles

Ensure the basin has a length to width ratio of at least 2:1 or more as specified. Grade the basin so that the bottom is level front to back and side to side. Discharge water into the basin in a manner to prevent erosion. The inlet into the basin should be on one end with the surface dewatering device on the opposite end of the basin. Use diversions with outlet protection to divert sediment-laden water to the upper end of the pool area to improve basin trap efficiency.

Install porous coir baffles as specified to ensure water does not flow under or around the baffles (Figure SBN-2). Baffles should be placed perpendicular to the flow and create near equal volumes within the basin.



Figure SBN-2 Example of porous baffle made of 700 g/m² coir erosion blanket as viewed from the inlet.

(from North Carolina Erosion and Sediment Control Planning and Design Manual.)

Install posts or saw horses across the width of the sediment trap.

Steel posts should be driven to a depth of 24 inches, spaced a maximum of 4 feet apart, and installed up the sides of the basin as well. The top of the fabric should be at least the height of the required storage volume elevation.

Install at least three rows of baffles between the inlet and outlet discharge point and at the locations specified in the plans. The three rows should create four near equal volumes in the basin.

When using posts, add a support wire or rope across the top to prevent sagging.

Wrap porous coir material (700 - 900 g/m²) over a sawhorse or the top wire. Hammer rebar into the sawhorse legs for anchoring. Attach fabric to a rope and a support structure with zip ties, wire, or staples. Each baffle should consist of 2 layers of coir fabric.

The bottom and sides of the fabric should be anchored in a trench or pinned with 8-inch erosion control matting staples.

Do not splice the fabric but use a continuous piece across the basin.

Erosion Control

Minimize the size of all disturbed areas.

Divert runoff from undisturbed areas away from the basin.

Use temporary diversions to prevent surface water from running onto disturbed areas.

Divert sediment-laden water to the upper end of the sediment pool to improve trap effectiveness.

Vegetate and stabilize the embankment, the emergency spillway and all disturbed areas including the basin bottom and side slopes. If the basin slopes and bottom are not vegetated, cover the surface with non-woven geotextile.

Flocculant

Place the specified flocculant in a turbulent flow location upstream of the basin to ensure proper mixing.

Safety

Because sediment basins that impound water are hazardous, the following precautions should be taken:

- Fence area and post warning signs if trespassing is likely.
- Ensure that the basin does not exceed design heights.

Construction Verification

Check the finished grades and configurations for all earthworks. Check elevations and dimensions of all pipes and structures.

Common Problems

Consult with registered design professional if any of the following occurs:

- Variations in topography on-site indicate sediment basin will not function as intended.
- Seepage is encountered during construction; it may be necessary to install drains.
- Design specifications for fill, pipe, seed variety or seeding dates cannot be met; substitutions may be required. Unapproved substitutions could lead to failure.

Maintenance

Inspect the sediment basin at least weekly and after each significant storm event (½ inch or greater).

If water remains turbid in the basin, reapply flocculant as specified.

Remove and properly dispose of sediment when it accumulates to ½ the design volume.

Remove trash and other debris from the skimmer, emergency spillway and pool area.

Periodically check the embankment, emergency spillway and outlet for erosion damage, piping, settling, seepage or slumping along the toe or around the barrel and repair immediately.

Remove the basin after the drainage area has been permanently stabilized, inspected, and approved. Do so by draining any water, removing the sediment to a designated disposal area, smoothing the site to blend with the surrounding area; then stabilize.

This Page Intentionally Left Blank

Bioretention Area (BA)



Source: Department of Environmental Resources, Prince George's County, MD

Practice Description

A bioretention area is a shallow, vegetated depression incorporated into a development's landscape to restore, as much as possible, an area's pre-development hydrology and provide both water quantity and water quality benefits.

Note: Only general guidance is provided for this practice. More specific information can be obtained from the Low Impact Development Handbook for the State of Alabama.

<https://adem.alabama.gov/programs/water/waterforms/LIDHandbook.pdf>

Typical Components of the Practice

- Site Preparation
- Product Installation
- Erosion and Sediment Control
- Construction Verification
- Maintenance

Construction [1, 3]

Prior to start of construction, bioretention area should be designed by a qualified design professional. Throughout the construction process, field personnel should refer to plans and specifications. Bioretention areas are generally finished last during construction to minimize sediment delivery.

Site Preparation

Install erosion and sediment control measures on adjacent areas before any site clearing, grading or excavation to prevent sediment from entering into the bioretention area.

Before the site is graded, rope off the bioretention area to prevent heavy equipment from compacting the underlying soils.

Determine the exact location of underground utilities.

If practical, redirect stormwater runoff to prevent runoff and sediment from entering the site during construction by using practices such as diversions and swales.

Stabilize any disturbed ground outside of where bioretention area is to be installed with vegetation.

Remove and stockpile the topsoil from the bioretention area.

Use earthmoving equipment with tracks or oversized tires to clear, grub and grade the site. Avoid normal rubber tires because they compact the subsoil and reduce its infiltration capabilities. Earthmoving in wet conditions should be avoided.

If curb openings exist that provide stormwater to the site they should be blocked during construction to prevent drainage onto the construction area.

Excavate the bioretention area to invert depth specified in design. Scarify remaining soil surface, taking measures not to compact underlying material.

Product Installation

Install underdrain system (including gravel diaphragm) and observation wells, if specified in design.

Backfill bioretention area with previously prepared soil mixture. See project design for specifications on soil mixture. Wet soil mixture and allow soil to settle.

Note – typically settlement will take ¼ of a day.

Installation and Maintenance of Best Management Practices

Add or remove soil mixture to achieve proper design grade. Leave appropriate space for mulch layer.

Install selected vegetation.

Mulch area and install area's entrance energy dissipater specified

Notes relating to Materials Installation

- Inspection of underdrain system (piping, connections, gravel bed, and any filter fabric) should be performed prior to filling in bioretention area. Gravel, pipe, and filter fabric should have manufacturer's tickets.
- If gravel diaphragm is part of underdrain system design, avoid dropping gravel into area from high levels (e.g. from a backhoe or front end loader). Gravel should be spilled directly over underdrain and spread manually.
- Allow bioretention soil to settle naturally as described above to avoid over-compaction. Do not provide any additional manual compaction. If speeding up this process is desired, pre-soak soil before placing in bioretention area.
- Soil should be overfilled above proposed surface so that post-settlement level of material will be at the proper grade. Soil materials can naturally compact up to 20% depending on soil type.

Erosion and Sediment Control

The importance of effective erosion and sediment control during and after construction should be thoroughly understood by responsible construction personnel.

Erosion and sediment control measures planned for the adjacent areas must be effective to prevent failure of the bioretention area.

Construction sequencing is vital. Construction activity in the contributing drainage area should be completed and disturbed areas stabilized before construction of bioretention area. Design drawings should specify the sequence of construction.

Construction Verification

Check the finished grades and configuration for all earthwork. Check elevations and dimensions of all pipes. Check soil additions for adherence to plan.^[4]

Common Problems

Consult with a qualified design professional if any of the following occur:

- Variations in topography or site geology indicate bioretention will not function as intended.
- Design specifications for fill, pipe, gravel, filter fabric and other material cannot be met. Unapproved substitutions could lead to failure.

Maintenance

Maintenance of bioretention areas is similar to the routine maintenance typical of any landscaped area. When plants native to the area are used, need of fertilizer, pesticide, and water is minimized.

Exercise caution during the application of fertilizers and pesticides in and around the bioretention area to prevent the possibility of surface and ground water contamination.

As plants mature in bioretention area, landscaping management requirements are lessened.

Typical aspects of bioretention maintenance include sediment and debris removal from the system, replacement of dead plant material, regulation of soil pH, repair of eroded areas, re-mulching, unclogging of underdrain, and repair of overflow structure repair.

Sediment must be kept from entering the bioretention area after construction.

An operation and maintenance checklist is helpful in ensuring that maintenance activities are scheduled appropriately. A template is available in one of the references.^[5]

References

- [1] Low Impact Development Handbook for the State of Alabama. Alabama Department of Environmental Management, Alabama Cooperative Extension System and Auburn University, <https://adem.alabama.gov/programs/water/waterforms/LIDHandbook.pdf>
- [2] Georgia Stormwater Management Manual, Volume 2 – Technical Manual. Section 3.2.3 Bioretention Areas
- [3] The Bioretention Manual. Prince George’s County, Maryland
- [4] Templates provided by <http://stormwatercenter.net>
Inspection checklist available at
http://www.stormwatercenter.net/Manual_Builder/CHECKLISTS/Filters/Construction/Bioretention%20construction%20inspection%20checklists.pdf
- [5] Operation and Maintenance checklist available at
http://www.stormwatercenter.net/Manual_Builder/CHECKLISTS/Filters/Operation%20and%20Maintenance/operation%20maintenance%20and%20management%20inspection%20checklists%20-%20Bioretention.pdf

This Page Intentionally Left Blank

Porous Pavement (PP)



Practice Description

Porous pavement is a permeable load-bearing layer that reduces runoff by providing infiltration and can be underlain by a stone reservoir for stormwater storage. The practice is applicable for areas with low traffic, such as overflow parking lots and lightly used access roads that are on relatively gentle slopes and permeable soils.

Concrete grids, modular pavement, or similar products will be considered as a part of this practice.

Note: Only general guidance is provided for this practice. More specific information can be obtained from the Alabama Low Impact Development (LID) Handbook.

<https://adem.alabama.gov/programs/water/waterforms/LIDHandbook.pdf>

Typical Components of the Practice

- Site Preparation
- Product Installation
- Full Exfiltration Systems
- Partial Exfiltration Systems
- Water Quality Exfiltration Systems
- Concrete Grids & Modular Pavements
- Erosion and Sediment Control
- Construction Verification
- Maintenance

Construction

Prior to start of construction, porous pavement should be designed by a qualified design professional. Plans and specifications should be referred to by field personnel throughout the construction process.

Consider the following guidance as construction proceeds.

Site Preparation

Before the site is graded, rope off the porous pavement area to prevent heavy equipment from compacting the underlying soils.

Determine the exact location of underground utilities.

Install Diversions to prevent runoff and sediment from entering the site during construction.

Use earthmoving equipment with tracks or oversized tires to clear, grub and grade the site. Avoid normal rubber tires because they compact the subsoil and reduce its infiltration capabilities. Earthmoving in wet conditions should be avoided.

Remove and stockpile topsoil.

Grade the site to design elevations and dimensions shown for the reservoir subgrade.

The subgrade should be reasonably smooth and free of loose rocks and clods, holes, depressions, muddy conditions or flowing water.

Product Installation

For All Products (based on the design plan)

Line the bottom and sides of the reservoir area with filter fabric, and install observation well, filler and filter stone. Typical installations include the following actions:

- using anchors to ensure the fabric is secured to the subgrade;
- installing the observation well at a designed location and elevation;
- placing stone of the specified gradation in uniform layers to the designed thickness and compacting each layer of stone lightly after it is placed;

Additional actions specific for the type of installation include the following guidelines:

Full Exfiltration System

After stone placement, install an emergency overland channel (curb or swale) to carry flows greater than the design storm.

Partial Exfiltration System

After stone placement, install perforated drainpipe and associated outlet structures at the locations and grades shown in the design plan. Drainpipes should be installed near the top of the stone reservoir.

Water Quality Exfiltration

After stone placement, install perforated drainpipe and associated outlet structures at the locations and grades shown in the design plan. Drainpipes should be installed near the top of the stone reservoir.

Concrete Grids and Modular Pavements

After stone placement, install perforated drainpipe and associated outlet structures at the locations and grades shown in the design plan. Drainpipes should be installed near the top of the stone reservoir.

Install the product and fill the open spaces within the pavement with gravel or other material according to the design plan and manufacturer's recommendations.

Notes relating to Materials Installation

- Rolling required for permeable asphalt, grid and modular pavement is critical and must be done strictly according to the design plan to prevent problems with infiltration and load bearing strength.
- After rolling is complete, all traffic should be kept out of the porous pavement area for a minimum of 1 day to allow proper hardening.
- If new utility lines are buried beneath the porous pavement site, do not construct the stone reservoir until all trench settlement has taken place.

Erosion and Sediment Control

Sediment control is critical during and after construction; therefore, erosion and sediment control measures planned for the adjacent areas must be effective to prevent loss of infiltration capacity of the porous pavement.

Vegetated filter strips should be placed around the porous pavement, concrete grids and modular pavements.

Reinforced silt fences should be placed around porous pavement, concrete grids and modular pavements while vegetation is being established.

Signs should be posted and construction personnel advised not to enter the parking lot or access area with muddy tires.

Store all construction materials and waste material well away from the porous pavement site.

Provide temporary fencing and post warning signs around the porous pavement until vegetation in the filter strip is established.

Install additional planned measures that are needed to drain and control stormwater runoff from the site.

Construction Verification

Check the finished grades and configuration for all earthwork. Check elevations and dimensions of all pipes and structures.

Common Problems

Consult with a qualified design professional if any of the following occur:

- Variations in topography or site geology indicate porous pavement will not function as intended.
- Design specifications for fill, pipe, gravel, filter fabric and asphalt paving material cannot be met. Unapproved substitutions could lead to failure.

Maintenance

Inspect the porous pavement after each storm event. Inspectors should check for ponding on the surface which might indicate local or widespread clogging.

The condition of the vegetative filter strip should be inspected.

The observation well should be checked several times in the first few months after construction. Water depth in the well should be measured at 0, 24, and 48 hour intervals after a storm.

The porous pavement site should be posted with signs indicating the nature of the surface, and warning against resurfacing the site with conventional pavement or the use of materials which could affect the infiltration capacity of the surface.

Sediment must be kept completely away from a porous pavement site after construction.

Asphalt type porous pavements should be vacuum swept at least 4 times per year, followed by high-pressure jet hosing to keep the asphalt pores open.

Potholes and cracks in asphalt porous pavement can be repaired using conventional, nonporous patching mixes as long as the cumulative area repaired does not exceed 10% of the parking lot area.

Spot clogging of the asphalt porous pavement layer can be relieved by drilling ½” holes through the porous asphalt layer every few feet. In cases where clogging occurs in a low spot in the parking lot, it may be advisable to install a drop inlet to route water into the stone reservoir.

Follow guidelines for porous pavement maintenance to maintain concrete grids and modular pavements. Where vegetation is planted in the grids, mowing, fertilizing and irrigation may be needed.

This Page Intentionally Left Blank

Stormwater Detention Basin (SDB)



Practice Description

A stormwater detention basin is a dam-basin practice designed to hold stormwater runoff and release the water slowly to prevent downstream flooding and stream erosion. The practice is an extremely effective water quality and peak discharge reduction measure. Its usage is best suited to larger, more intensively developed sites. Structure life is 10 years or more. A stormwater detention basin can have a permanent pool of water or be designed to have a dry basin (typical). A detention basin can be designed to also serve as a sediment basin during the construction period.

Typical Components of the Practice

- Site Preparation
- Keyway Trench
- Principal Spillway
- Embankment
- Emergency (Auxiliary) Spillway
- Skimmer and Baffles
- Erosion Control
- Safety
- Construction Verification
- Maintenance

Construction

Prior to start of construction, the stormwater detention ponds should be designed by a qualified design professional.

Plans and specifications should be referred to by field personnel throughout the construction process. The measure should be built according to the planned grades and dimensions and include all essential components. Follow all federal, state and local requirements on impoundments.

Consider the following guidance as construction proceeds.

Site Preparation

Locate all underground utilities to ensure avoidance.

Clear, strip, grub and excavate the dam location, removing all woody vegetation, rocks and other objectionable material, such as soft, wet, or sandy soils. Stockpile surface soils with high organic content for later use. Dispose of trees, limbs, logs and other debris in designated disposal areas.

If possible, construct the dam prior to clearing and disturbance of the pool area. Stockpile any surface soil having high amounts of organic matter for later use.

Where practical, maintain existing vegetation of at least 25 feet around the pool as a filter strip (see *Preservation of Vegetation* practice).

Keyway Trench

Excavate the keyway trench along the centerline of the planned embankment to a depth determined by the qualified design professional (at least 2 feet). The trench bottom elevation should extend up both abutments to the emergency spillway elevation and have a bottom width of at least 8 feet and have side slopes no steeper than 1.5:1 or flatter. Compaction requirements for the keyway backfill will be the same as those for the embankment.

Principal Spillway

Prepare the pipe bedding and situate the spillway barrel (pipe) and riser on a firm, even foundation.

Place around the barrel a 4" layer of moist, clayey, workable soil (not pervious material such as sand, gravel or silt), and compact with hand tampers to at least the density of the foundation soil. Do not raise the pipe from the foundation when compacting under the pipe haunches. Continue with backfill of the pipe in 4" to 6" uncompacted layers scarifying the surface between each compacted layer. All backfill material within 2 feet of the pipe (beside the pipe and above the pipe) should be compacted with hand tampers only.

Install the anti-seep collars or sand drainage diaphragm according to the design specifications.

Set the top of the riser at the elevation shown on the design drawings to allow the detention pond to store the design runoff. Install the 4 inch dewatering orifice at the designed elevation on the side of the riser pipe and complete with a trash rack device.

Embed the riser into the concrete anti-flotation block as shown on the design drawing. The concrete block should be constructed to the dimensions shown on the drawings to balance the buoyant force acting on the riser.

Install the trash rack around the riser inlet. The trash rack should have the minimum dimensions shown on the design.

At the pipe outlet, install outlet protection according to the design plan (if not specified, use a riprap apron at least 5 feet wide to a stable grade).

Embankment

Scarify the embankment foundation before placing fill.

Use fill from predetermined borrow areas. It should be clean, stable, mineral soil free of organic material, roots, woody vegetation, rocks and other debris; and must be wet enough to form a ball without crumbling, yet not so wet that water can be squeezed out.

Place the most permeable soil in the downstream toe and the least permeable in the center portion of the dam.

Place the fill material in 6" to 9" continuous uncompacted layers over the length of the dam. Fill should then be compacted to a 4" to 6" thick continuous layer (one way is by routing pneumatic tired construction equipment over the dam so that each layer is traversed by at least 4 passes of the equipment). Compacted layers with a slick surface should be scarified prior to the next lift being placed in order to promote bondage between the layers.

Protect the principal spillway barrel with 2 feet of hand tamped, compacted fill before traversing over the pipe with equipment.

Construct and compact the dam to an elevation 10% above the design height to allow for settling. The embankment should have a minimum 8 feet top width and 2.5:1 side slopes (3:1 for mowable slopes), but the design may specify additional width and gentler side slopes.

Place a stake marking the depth of sediment accumulation at which sediment must be cleaned out of the basin (50% of design storage volume).

Emergency (Auxiliary) Spillway

Construct the spillway at the site located, to the dimensions, and utilizing the surface treatments specified by a qualified design professional according to the

design plan. In most all cases, the emergency spillway will be constructed in undisturbed soil around one end of the embankment so that any flow will return to the receiving channel without damaging the embankment.

Skimmer and Baffles

Skimmer and baffles will be required if the stormwater detention basin is to serve as a sediment basin during the construction phase of the project.

Assemble the skimmer following the manufacturer's instructions, or as designed.

Lay the assembled skimmer on the bottom of the basin with the flexible joint connected watertight at the base of the riser pipe. Be sure to attach a rope to the skimmer and anchor it to the side of the basin. This will be used to pull the skimmer to the side for maintenance.

Prevent the skimming device from settling into the mud by excavating a shallow pit under the skimmer or providing a low support under the skimmer of stone or timber.

Install a minimum of 3 porous coir baffles as specified and ensure flows do not go under or around the baffles.

Erosion Control

Minimize the size of all disturbed areas. At the completion of each phase of construction, stabilize the disturbed areas to minimize erosion.

Stabilize the spillway with vegetation as soon as grading is complete; or install paving material to finished grade if the spillway is not to be vegetated.

Use temporary diversions to prevent surface water from running onto disturbed areas.

Divert sediment-laden water to the upper end of the sediment pool to improve trap effectiveness.

Direct all runoff into the pond at low velocity.

Establish vegetation on all disturbed areas not previously treated including the bottom and side slopes of the basin.

Safety

Because stormwater detention basins that impound water are hazardous, the following precautions should be taken:

Provide a means of dewatering the basin between storm events.

Fence area and post with warning signs if trespassing is likely.

Construction Verification

Check the finished grades and configuration for all earthwork. Check elevations and dimensions of all pipes and structures.

Common Problems

Consult with a qualified design professional if any of the following occur:

- Variations in topography on site indicate detention pond will not function as intended.
- Seepage is encountered during construction; it may be necessary to install drains.
- Design specifications for fill, pipe, seed variety or seeding dates cannot be met; substitutions may be required. Unapproved substitutions could lead to failure.

Maintenance

Inspect the stormwater detention basin after each storm event.

Remove and properly dispose of sediment when it accumulates to ½ the design volume.

Periodically check the embankment, emergency spillway and outlet for erosion damage, piping, settling, seepage or slumping along the toe or around the barrel; and repair immediately.

Remove trash and other debris from the riser, skimmer, emergency spillway and pool area. Remove nuisance vegetation on embankment.

Remove animals that burrow into the dam.

This Page Intentionally Left Blank

Buffer Zone (BZ)



Practice Description

A buffer zone is a strip of plants adjacent to land-disturbing sites or bordering streams, lakes, and wetlands which provides streambank stability, reduces scour erosion, reduces storm runoff velocities and filters sediment in stormwater. This practice applies on construction sites and other disturbed areas that can support vegetation and can be particularly effective on floodplains, next to wetlands, along stream banks and on steep, unstable slopes.

Typical Components of the Practice

- Preservation and Protection of Existing Vegetation
- Site Preparation
- Soil Amendments (lime and fertilizer)
- Planting Desired Vegetation
- Mulching
- Maintenance

Installation (Preservation)

Prior to start of construction, buffer zones should be designed by a qualified design professional. Plans and specifications should be referred to by field personnel throughout the installation process.

Preserve vegetation on designated areas shown in plan. In the absence of a plan, maintain a buffer of existing vegetation with a minimum width for shoreline or stream bank protection of at least 35 feet. Local ordinances may require a wider buffer. Narrower buffer zones may be sufficient on steep slopes that are narrower than 35 feet.

Installation (Plantings)

Prior to start of construction, buffer zones should be designed by a qualified design professional. Plans and specifications should be referred to by field personnel throughout the installation process.

Site Preparation

Install planned measures such as silt fences and diversions before grading and seedbed preparation. In the absence of a plan and before grading and seedbed preparation, install other necessary measures which may include silt fences and diversions. Clear area of clods, rocks, etc. that would interfere with seedbed preparation; smooth the area before the soil amendments are applied and firm the soil after the soil amendments are applied.

Soil Amendments (lime and fertilizer)

Apply lime and fertilizer according to the plan or by soil test recommendations. In the absence of a plan or soil test recommendations, apply agricultural limestone at the rate of 2 tons per acre (90 lbs per 1000 ft².) and 10-10-10 fertilizer at the rate of 1000 lbs per acre (25 lbs per 1000 ft².). Apply ground agricultural limestone unless a soil test shows pH of 6.0 or greater. Incorporate amendments to a depth of 4" to 6" with a disk or chisel plow.

Planting Desired Vegetation

Plant desired vegetation according to the design plan. In the absence of a plan use installation guidelines for Permanent Seeding, Tree Planting on Disturbed Areas, or Shrub, Vine and Groundcover Planting.

Mulching

Spread mulch according to guidelines in the Mulching practice.

Common Problems

Consult with qualified design professional if any of the following occur:

- Soil compaction can prevent adequate plant growth. Compaction should be addressed during site preparation.

Installation and Maintenance of Best Management Practices

- Design specifications for plants (variety, seeding/planting dates) and mulch cannot be met; substitutions may be required. Unapproved substitutions could lead to failure.

Problems that require remedial actions:

- Erosion, washout and poor plant establishment – repair eroded surface, reseed, reapply mulch and anchor.
- Mulch is lost to wind or stormwater runoff – reapply mulch and anchor.

Maintenance

Replant trees, grass, shrubs or vines where needed to maintain adequate cover for erosion control. Maintain grass plantings with periodic applications of fertilizer and mowing.

This Page Intentionally Left Blank

Channel Stabilization (CS)



Practice Description

Channel stabilization is stabilizing an open channel, either natural or artificial, in which water flows with a free surface. The purpose of this practice is to establish a non-erosive channel. This practice applies to the stabilization of open channels and existing streams or ditches with drainage areas less than 1 square mile.

Typical Components of the Practice

- Scheduling
- Site Preparation
- Installation
- Rock Riprap Lining
- Concrete Lining
- Erosion Control
- Safety
- Construction Verification
- Maintenance

Construction

Prior to start of construction, channel stabilization should be designed by a qualified design professional. Plans and specifications should be referred to by field personnel throughout the construction process.

Consider the following guidance as construction proceeds.

Scheduling

Schedule installation during a period that includes the planting season or establishment period for the species that will be used for the adjoining Streambank Protection. In addition, use local weather forecasts to avoid installation activities during rain events that can potentially create abnormal flows and flooding.

Site Preparation

Follow all local, state, and federal government regulations on stream modifications.

Determine exact location of all underground activities.

Remove trees, brush, stumps, and other objectionable materials according to the design plan. Where possible, vegetation will be left standing, and stumps will not be removed.

Spoil material resulting from clearing and grubbing should be disposed of according to the design plan.

The foundation for structures should be cleared of all undesirable materials prior to the installation of the structures.

Installation

Channels may be stabilized by using one or more of the following methods:

Rock Riprap Lining

Where excavation is required, channels will be excavated from one side leaving vegetation on the opposite side.

Excavation should be at the locations and grades shown on the drawings.

Spoil material resulting from channel excavation should be disposed of according to the design plan.

If required by the plans, place geotextile fabric or a granular filter as a bedding material for the riprap. Install riprap of the specified gradation to the lines and

Installation and Maintenance of Best Management Practices

grades shown in the design plan. Ensure that the subgrade for the filter and riprap follows the required lines and grades shown in the plan.

Riprap may be placed by equipment. Care should be taken to avoid punching or tearing of the filter cloth during placement of rock. Repair any damage by removing the riprap and placing another piece of filter cloth over the damaged area. All connecting joints should overlap a minimum of 1.5 feet so that the upstream piece of fabric lies on top of the downstream piece of fabric. If the damage is extensive, replace the entire filter cloth.

Installation usually includes some bank shaping. If bank shaping is included, follow details in the design plan and refer to the construction guidelines in Streambank Protection practice.

Concrete Lining

Where excavation is required, channels will be excavated from one side leaving vegetation on the opposite side.

Excavation should be at the locations and grades shown on the drawings.

Spoil material resulting from channel excavation should be disposed of according to the design plan.

Install concrete lining using concrete of the specified design strength according to the lines and grades in the design plan.

Installation of concrete linings usually includes some bank shaping. If bank shaping is included, follow details in the design plan and refer to the construction guidelines in Streambank Protection practice.

Place filter material and weep holes according to the plans. Place concrete according to ACI standards. Concrete on sloping surfaces should be placed from the bottom of the slope toward the top, at the required thickness, and with good vibration.

As required by the design plan, install expansion joints at the locations shown in the plan.

As required by the design plan, install welded wire fabric in the concrete forms before placing concrete.

Divert flow around the concrete lining until the concrete has reached 75% of its design strength (usually 7 days after concrete placement).

Grade Stabilization Structures

Where excavation is required, channels will be excavated from one side leaving vegetation on the opposite side.

Excavation should be at the locations and grades shown on the drawings.

Spoil material resulting from clearing, grubbing and channel excavation should be disposed of according to the design plan.

Install the structure to the lines and grades shown in the design plan.

If earthfill is required, install according to the design plan and refer to the construction guidelines for Sediment Basin embankments.

If rock riprap is required, install according to the design plan refer to the installation requirements listed earlier for Riprap-lined Swale.

Other products used, including concrete, masonry, steel, aluminum or treated wood should be installed according to details in the design plan. Installation usually includes some bank shaping. If bank shaping is included, follow details in the design plan and refer to the construction guidelines in the Streambank Protection practice.

Erosion Control

Seeding, fertilizing, and mulching of the disturbed areas should be done immediately after construction and conform to the guidelines in the design plan. If vegetation establishment specifications are not included in the design plan see the appropriate practice Permanent or Temporary Seeding (See Volume 1 and 2 of The Blue Book for guidelines).

Safety

Store all construction materials well away from the stream. Consider weather forecasts when determining risks of damage by flooding.

Equipment used to construct channel stabilization measures should be free of leaks of fuel and hydraulic fluids to prevent contamination of surface waters. Operation of equipment in the stream should be minimized. At the completion of each workday, move all construction equipment away from the stream to prevent damage to equipment by flooding. Consider weather forecasts when determining risks of flooding.

The following precautions should be taken:

- Exercise caution on steep slopes.
- Fence area and post warning signs if trespassing is likely.

Installation and Maintenance of Best Management Practices

- All equipment used for practice installation should be free of leaks of gas, oil, and hydraulic fluid. Measures should be in place to prevent accidental spills from entering the stream.
- Equipment should not be operated within flowing water in the stream.

Construction Verification

Check material and finished grades to determine if job meet specifications in the design plan.

Common Problems

Variations in site conditions indicate practice will not function as intended: changes in plan may be needed.

Design specifications for materials cannot be met; substitution may be required. Unapproved substitutions could result in failure of the practice.

Maintenance

All structures should be maintained in an “as built” condition.

Check the stream channel at the construction site after each major event until the job is considered mature and a success.

Structural damage caused by storm events should be repaired as soon as possible to prevent further damage to the structure or erosion of the streambank.

Unwanted brush or excessive sediment that will impede flow should be removed in order to maintain design conditions.

This Page Intentionally Left Blank

Stream Diversion Channel (SDC)



Practice Description

A stream diversion channel is a temporary practice to convey stream flow in an environmentally safe manner around a construction site while a permanent structure or conveyance is being installed in the stream channel.

Typical Components of the Practice

- Site Preparation
- Erosion and Sediment Control
- Excavation
- Lining Placement
- Stream Diversion
- Safety
- Construction Verification
- Maintenance

Construction

Prior to the start of construction, stream diversion channels are required to be designed by a qualified design engineer registered in the State of Alabama. In-stream projects of this nature are subject to the rules and regulations of the U. S. Army Corps of Engineers for in-stream modifications (Clean Water Act Section 404 permit) and if applicable, ADEM CWA Section 401 water quality certification. The stream diversion channel should be planned and installed in such a manner and time (dry season) that the impact to fisheries and the aquatic environment is minimized. A pictorial representation of a stream diversion channel is shown in Figure SDC-1. If a temporary stream crossing (TSC) is required for access, it should be constructed either up or downstream of the temporary diversion channel.

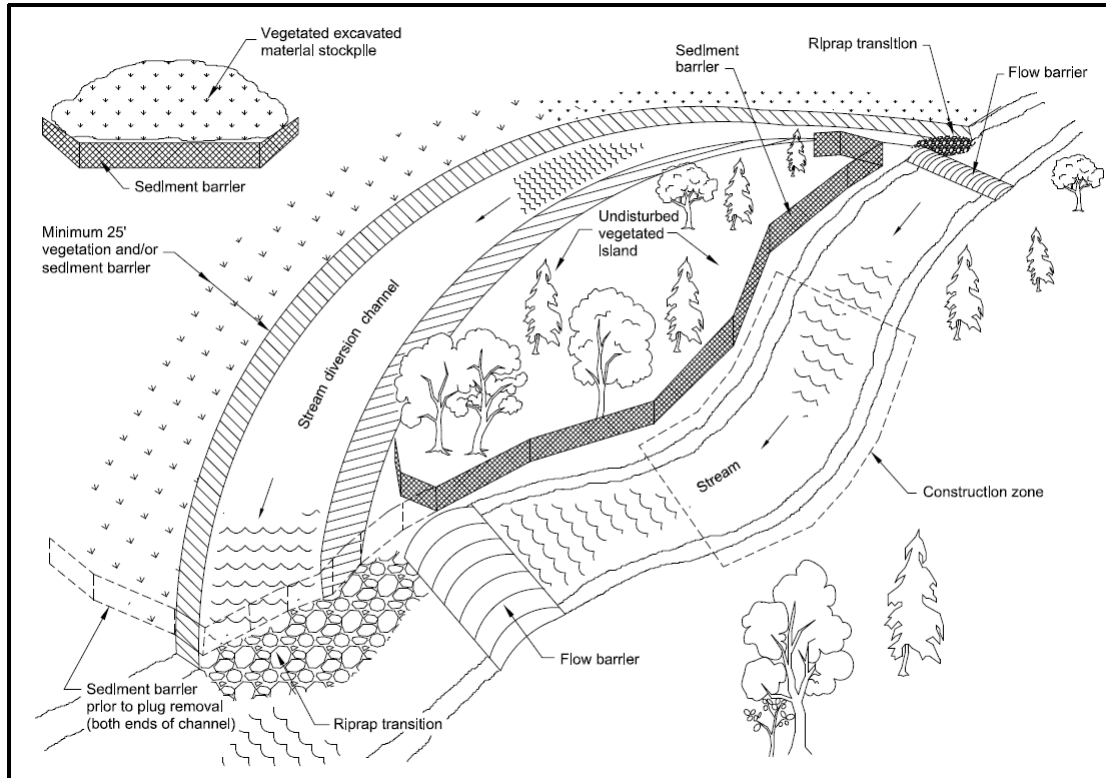

Figure SDC – 1: Typical Stream Diversion Channel Layout.

Site Preparation

Determine exact location of underground utilities.

Maintain vegetation around the stream until the stream diversion channel has been fully completed including vegetation. Clear only enough of the stream diversion channel area for the next day's work.

The centerline of the stream diversion channel should be established in the plans or by the responsible engineer. Slope and grade stakes should be established for use during excavation.

Erosion and Sediment Control

Sediment barrier or other sediment control practices to protect the stream from the construction of the diversion channel should be installed prior to any land disturbance. The stockpile for excavated material should be located well away from the work area with sediment control practices installed prior to placement of stockpiled materials. All construction areas should be seeded and mulched as soon as work is complete. Maintain a minimum 25 ft. vegetated grass filter around the stream diversion channel.

Excavation

A 25 foot undisturbed plug should be left at the exit and entrance of the stream diversion channel until the diversion channel itself has been finished. The stream diversion channel should be excavated according to the dimensions and grade shown in the construction plans beginning at the downstream end next to the plug and continue in an upstream direction. The grade of the stream diversion channel should be uniform and continuous in order to tie into the existing stream bottom elevations without any over falls that would create turbulence. Construction equipment should not be allowed to operate in flowing waters. Construction equipment should be well maintained to prevent drip/leaks of oil, hydraulic fluid, etc. Water that collects in the stream diversion channel excavation should be pumped as necessary to a settling basin prior to its discharge. The excavated material should be hauled to the stockpile location.

Lining Placement

Different lining materials can be specified for the stream diversion channel. Install the selected linings according to the construction specifications.

When rolled products like polyethylene film or geotextile fabric are specified for use as a channel lining, the product should be placed so that one width of material will cover the entire channel bottom and slopes while also providing enough material for a minimum 6 inch anchorage at the top of the bank. The upstream end of the material shall be buried at least 2 feet from top of bank to top of bank with additional trench anchorages of at least 1 ft. x 1 ft. at 50 foot intervals. Upstream sections of material shall overlap downstream sections by at least 2 feet and occur at a trench anchorage location. Polyethylene film shall be at least 6 mil thick and be capable of maintaining strength against the effects of ultraviolet light for a period of at least 60 days.

Pre-manufactured products like turf reinforcement mats (TRM), flexible concrete linings, and other similar products shall be designed and installed according to the manufacturer's recommendations.

Block sod shall be covered with erosion control netting and staked at minimal 3 ft. x 3 ft. spacing and also at the upstream edge of each piece of sod.

Generally, non-woven geotextile fabric is used underneath riprap linings. Additional protection such as riprap may be needed at the entrance and exit portion of the stream diversion channel to ensure scour does not occur in the existing stream bed or bank.

Stream Diversion

After the lining between the upstream and downstream plugs have been installed, the downstream plug should be removed first and the transition installation completed. Next, the upstream plug should be removed and the transition installation completed. Finally, the stream flow should be diverted into the stream diversion channel using an upstream flow barrier as specified in the plans and in such a manner to minimize sediment delivery into the stream. Allow time

for the stream to drain so that aquatic organisms have an opportunity to move or migrate downstream. The downstream flow barrier, if required, can then be installed so that work can commence for the installation of the permanent structure.

Safety

The following precautions should be taken:

- Exercise caution on steep slopes.
- Fence area and post warning signs if trespassing is likely.
- Store equipment, tools and materials well away from the stream during non-work periods. Consider weather forecasts when determining risks of damage to equipment, tools and materials by flooding.
- All equipment used for practice installation should be free of leaks of gas, oil, and hydraulic fluid. Measures should be in place to prevent accidental spills from entering the stream.
- Equipment should not be operated within flowing water in the stream.

Construction Verification

Check finished grades and cross sections throughout the length of the stream diversion channel.

Verify the stream diversion channel cross section dimensions at several locations to confirm plan specifications.

Common Problems

Consult with a qualified design professional if any of the following occur:

- The topography of the site does not allow the practice to function as intended and changes in the plan are needed.
- The design specifications for materials cannot be met and substitutions may be necessary. Unapproved substitutions could result in an unstable diversion channel.

Maintenance

Inspect the stream diversion channel at regular intervals and especially after storm events, check for lining displacement, erosion of the lining, and erosion at the transition areas.

Repair damaged lining and erosion promptly.

_____ Installation and Maintenance of Best Management Practices

Once the permanent structure has been completed, flow can be diverted into the new conveyance structure and the stream diversion channel decommissioned. The decommissioning should occur in such a manner to minimize erosion and sediment runoff into the stream system. Lining materials should be recycled or disposed of properly.

This Page Intentionally Left Blank

Streambank Protection (SP)



Practice Description

Streambank protection is the stabilization of the side slopes of a stream. Streambank protection can be vegetative, structural or a combined method (bioengineering) where live plant material is incorporated into a structure. Vegetative protection is the least costly and the most compatible with natural stream characteristics. Additional protection is required when hydrologic conditions have been greatly altered and stream velocities are excessively high. Streambank protection is often necessary in areas where development has occurred in the upstream watershed and full channel flow occurs several times a year.

Typical Components of the Practice

- Vegetative Measures
 - Scheduling
 - Site Preparation
 - Installation
 - Erosion Control
 - Safety
 - Inspection
 - Maintenance

- Structural Measures
 - Scheduling
 - Site Preparation
 - Installation
 - Construction Verification

Vegetative Measures – Installation

Prior to start of construction, streambank protection, for each unique channel reach, should be designed by a qualified design professional and/or an interdisciplinary team. Plans and specifications should be referred to by field personnel throughout the construction process.

Scheduling

Schedule installation during a period that includes the planting season or establishment period for the species that is to be established. In addition, use local weather forecasts to avoid installation during rain events that can potentially create wetness and flooding.

Site Preparation

Follow all local, state, and federal government regulations on stream modifications. Determine exact location of all underground activities.

Stabilize the channel bottom as specified in the design plan before streambank protection measures are installed.

Installation

Plant live plant materials, cuttings, or other forms of plant materials according to the planting plan.

Erosion Control

Minimize the size of all disturbed areas during site preparation and stabilize as soon as each phase of construction is complete.

Establish vegetation to stabilize all disturbed areas immediately after construction.

Safety

The following precautions should be taken:

- Exercise caution on steep slopes.
- Fence area and post warning signs if trespassing is likely.

Installation and Maintenance of Best Management Practices

- Store equipment, tools, and materials well away from the stream during non-work periods. Consider weather forecasts when determining risks of damage to equipment, tools, and materials by flooding.
- All equipment used for practice installation should be free of leaks of gas, oil, and hydraulic fluid. Measures should be in place to prevent accidental spills from entering the stream.
- Equipment should not be operated within flowing water in the stream.

Construction Verification

Check to see that planting and seeding was done in compliance with the design specifications.

Structural Measures - Construction

Prior to start of construction, streambank protection, for each unique channel reach, should be designed by a qualified design professional and/or an interdisciplinary team. Plans and specifications should be referred to by field personnel throughout the construction process.

Scheduling

Schedule installation during a period that is least likely to have flooding and that includes the planting season for the species that are to be established in association with the structural measures.

Site Preparation

Follow all local, state, and federal government regulations on stream modifications. Determine exact location of all underground activities.

Stabilize the channel bottom as specified in the design plan before streambank protection measures are installed.

Remove brush and trees only if absolutely necessary to make the site suitable to install the planned measures.

Grade or excavate the areas specified in the design plan, but limit earthmoving to that absolutely necessary to make the site suitable to install the planned measures.

Installation

Riprap

Install riprap of the specified gradation to the lines and grades shown in the design plan. Installation usually includes some bank shaping.

Place geotextile fabric or a granular filter between the riprap and the natural soil and placement of the rock.

Ensure that the subgrade for the filter and riprap follows the required lines and grades shown in the plan. Low areas in the subgrade on undisturbed soil may also be filled by increasing the riprap thickness.

Riprap may be placed by equipment. Care should be taken to avoid punching or tearing of the geotextile fabric cloth during placement of rock. Repair any damage by removing the riprap and placing another piece of filter cloth over the damaged area. All connecting joints should overlap a minimum of 1.5 feet with the upstream edge over the downstream edge. If the damage is extensive, replace the entire geotextile fabric.

Gabions

Install gabions and related materials in accordance with the design plan. Use only durable crushed limestone, dolomite, or granite rock. Shale, siltstone, and weathered limestone should not be used.

Place geotextile fabric or a granular filter between streambank material and gabions. Install gabions and counterforts as indicated in the design plan.

Fabric Formed Revetments

Install revetments according to manufacturer's recommendations. Typically, a site must be cleared and grubbed. Next, the fabric formed revetments are sewn or zipped together at the site to form continuous coverage. Once the fabric is in place, it is pumped full of grout to form a solid, hard and impervious cover.

Reinforced Concrete

Install reinforced concrete according to the design plan. Installation usually includes some bank shaping, placing a filter fabric or a granular filter between the streambank material and the retaining wall or bulkhead, and anchoring.

Anchor the foundation for these structures to a stable, nonerodable base material such as bedrock. Also, water stops should be installed at all joints in concrete retaining walls.

Combined Methods of Streambank Protection (Soil Bioengineering)

Grid pavers, cellular confinement matrices and other appropriate structural measures used with vegetative measures should be designed and installed in accordance with manufacturer's recommendations.

Erosion Control within Soil Bioengineering Applications

Minimize the size of all disturbed areas.

Install vegetative material (stakes, wattles, etc.) according to the design plan and make seedings immediately after construction activities to stabilize all other disturbed areas needing vegetation.

Safety

Store all construction materials well away from the stream. Consider weather forecasts when determining risks of damage by flooding.

At the completion of each workday, move all construction equipment out of and away from the stream to prevent damage to equipment by flooding. Consider weather forecasts when determining risks of flooding.

The following precautions should be taken:

- Exercise caution on steep slopes.
- Fence area and post warning signs if trespassing is likely.
- All equipment used for practice installation should be free of leaks of gas, oil, and hydraulic fluid. Measures should be in place to prevent accidental spills from entering the stream.
- Equipment should not be operated within flowing water in the stream.

Construction Verification

Check cross section of the channel, thickness of structural product used and confirm the presence of filter cloth between the product and the streambank.

Check to see that planting and seeding was done in compliance with the design specifications.

Common Problems

Consult with a qualified design professional if any of the following occur:

- Variations in topography on site indicate practice will not function as intended; changes in plan may be needed.
- Design specifications for vegetative or structural protection cannot be met; substitution may be required. Unapproved substitutions could result in erosion damage to the streambank.

Maintenance

Check the streambank for rill and gully erosion after every storm event.

Repair eroded areas with appropriate plantings, structural materials, or new plants.

Check the streambank for signs of voids beneath gabions, riprap, and concrete.

Deterioration of the filter fabric or granular material should be repaired - make needed repairs with similar material.

Protect new plantings from livestock.

Check the streambank for reduction in stream capacity; caused by overgrowth of vegetation on the streambank. Selectively remove overgrown vegetation at regular intervals to maintain capacity and to maintain desired plant communities.

Temporary Stream Crossing (TSC)



Photo courtesy of Steve Taylor, Auburn University Biosystems Engineering

Practice Description

A temporary stream crossing is a short term road crossing constructed over a stream for use by construction traffic to prevent turbidity and streambed disturbance caused by traffic. A temporary stream crossing can be a low water crossing, a culvert crossing, or a bridge with or without embankment approaches. Temporary stream crossings are applicable on construction sites where traffic must cross streams during construction.

Typical Components of the Practice

- Scheduling
- Site Preparation
- Installation and Removal Low Water Crossing
- Culvert Crossing
- Bridge
- Erosion Control
- Safety
- Construction Verification
- Maintenance

Construction

Prior to start of construction, a temporary stream crossing should be designed by a qualified design professional. Plans and specifications should be referred to by field personnel throughout the construction process.

Scheduling

Attempt to construct temporary stream crossings during dry periods and relatively low flows to minimize stream disturbance. Use local weather forecasts to avoid installation during rain events that can potentially create turbidity.

Site Preparation

Ensure that all necessary materials are on the site before any work begins. If planned, construct a bypass channel, and dewater the construction site before undertaking other work. Refer to plans.

Installation and Removal Low Water Crossing

Excavate the foundation for the temporary crossing according to the design plan and in such a manner that the final finished surface is level with the stream bed.

Excavate roadways through the abutment approaches (bank) to the crossing according to the design plan.

Place the specified type of geotextile over the width and length of the crossing subgrade and anchor it in place as specified in the plans. Next, place riprap of the specified gradation to the required thickness across the channel. Finally, place a wearing course of gravel or crushed rock of the specified gradation to the required thickness over the riprap.

Remove gravel and excess rock riprap as soon as it is no longer needed. Restore original contours to the channel, leaving rock riprap level with the streambed.

Culvert Crossing

After diverting the stream flow (if planned), excavate the foundation for the culvert. Situate the culvert on a firm, even foundation and keep the culvert parallel to the direction of flow. See Figure TSC-1.

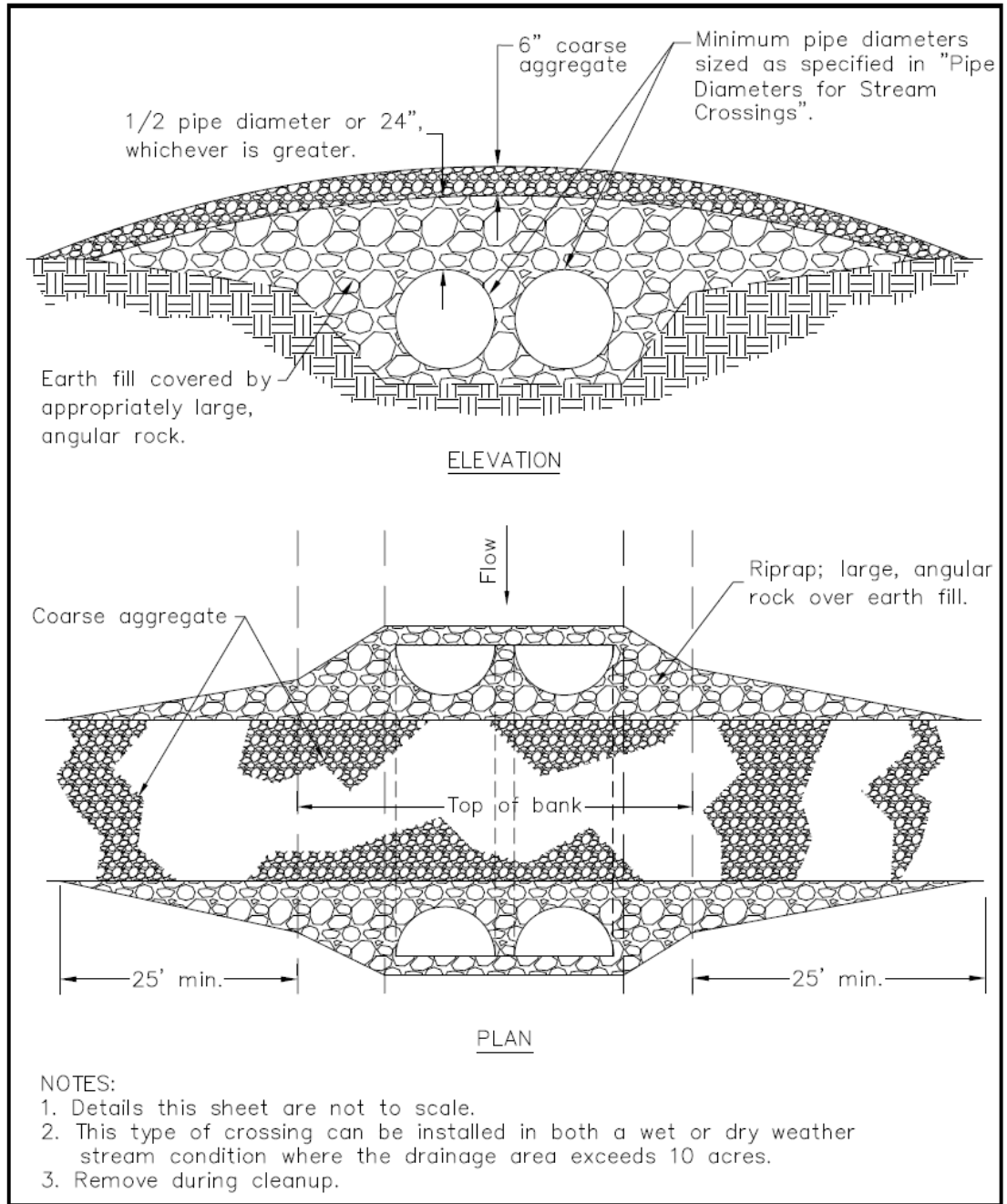

Figure TSC-1 Typical Temporary Culvert Stream Crossing

Place a 4" layer of moist, clayey, workable soil (not pervious material such as sand, gravel or silt) around the culvert. Compact by hand to at least the density of the embankment soil. (Do not raise the culvert from the foundation when compacting under the culvert haunches.) Continue with backfill of the pipe in 4" to 6" uncompacted layers scarifying the surface between each compacted layer. All backfill material within 2 foot of the pipe (beside the pipe and above the pipe) should be compacted with hand tampers only.

Extend the end of the culvert 2 feet beyond the toe of the fill slope. The outlet end of the culvert should be placed on a stable natural streambed. If this is not possible, install a riprap apron at least 5 feet wide and 10 feet long to a stable grade.

All backfill material within 2 foot of a culvert (beside the pipe and above the pipe) should be compacted with hand tampers only. Heavy equipment should not be allowed on top of the culvert until a minimum of 2 feet of hand compacted material is placed.

If an embankment is required, use fill from predetermined borrow areas. It should be clean, stable mineral soil free of roots, woody vegetation, rocks, and other debris. It must be wet enough when placed to form a ball without crumbling yet not so wet that water can be squeezed out. Compact the fill material in 6" to 8" continuous layers over the length of the embankment. One way is by routing construction equipment over the embankment so that each layer is traversed by at least one wheel of the equipment. Construct and compact the culvert-crossing embankment to 10% above the design height to allow for settling.

Remove culvert as soon as it is no longer needed and restore streambed to original contour.

Bridge

Excavation

If excavation is required, excavate roadways through the abutment approaches (bank) according to the design plan.

Construct the bridge or install a prefabricated structure according to the design plan. A cable should be tied to one corner of the bridge frame with the other end fastened to a secure object to prevent flood flows from carrying the bridge downstream.

Embankment

Use fill from predetermined borrow areas. It should be clean, stable mineral soil free of roots, woody vegetation, rocks, and other debris and must be wet enough to form a ball without crumbling yet not so wet that water can be squeezed out.

Compact the fill material in 6" to 8" continuous layers over the length of the embankment. One way is by routing construction equipment over the embankment so that each layer is traversed by at least one wheel of the equipment.

Construct and compact the temporary stream crossing embankment to 10% above the design height to allow for settling.

Erosion Control (all kinds of temporary stream crossings)

Minimize the size of all disturbed areas and vegetate as soon as each phase of construction is complete. Install riprap or establish vegetation on the slopes of the embankment of the temporary stream crossing. Rip-rap should be placed on the entrance slope of culvert systems according to the design plan.

Direct all overland flow at low velocity to the ditches along the approach roads.

Safety

Store all construction materials well away from the stream. Consider weather forecasts when determining risks of damage by flooding.

Equipment used to construct stream crossings should be free of leaks of fuel and hydraulic fluids to prevent contamination of surface waters. Operation of equipment in the stream should be minimized. At the completion of each workday, move all construction equipment away from the stream to prevent damage to equipment by flooding. Consider weather forecasts when determining risks of flooding.

The following precautions should be taken:

- Exercise caution on steep slopes.
- Fence area and post warning signs if trespassing is likely.
- All equipment used for practice installation should be free of leaks of gas, oil, and hydraulic fluid. Measures should be in place to prevent accidental spills from entering the stream.
- Equipment should not be operated within flowing water in the stream.

Construction Verification

Check finished grade and size of culvert. Check to see if culvert is free of obstructions.

Common Problems

Consult with qualified design professional if any of the following occur:

- Variations in topography on site indicate crossing will not function as intended; changes in plan may be needed.
- Design specifications for fill or conduit cannot be met; substitution may be required. Unapproved substitutions could result in the crossing being washed out.

Maintenance

Inspect the temporary stream crossing for damage to the structure or the vegetation after each storm event.

Repair any damages found during inspections.

Remove debris, trash and other materials that restrict flow from the culvert or bridge.

Chapter 4

Inspection of Construction Sites

This chapter provides information about inspecting erosion control, sediment control and stormwater management practices during the construction period. It covers inspections using visual procedures that can be evaluated by trained individuals. It does not cover inspections that involve water sampling or testing. It does not cover the installation of the practices or measures that may be used for erosion and sediment control and stormwater management.

The information in this chapter should be considered generic with the recognition that state and local regulations may provide very specific requirements related to inspector credentials, frequency of inspections, report format, submission of reports to permitting authorities, and retention of reports.

Requirements for Inspectors

Inspections should be made by qualified persons that understand how practices are to be properly installed, how they should perform, and how practices should be maintained. Inspectors should have enough knowledge about each practice used to determine if it is effective and whether or not it needs maintenance or repair. Inspectors should know enough about the practices to realize that there may need to be an additional practice or a different practice in a problem area. However, changes in the plan are the responsibility of the design professional.

Inspectors do not have to understand how a practice is designed, although the more a person knows about a practice the better the person will understand how the practice should be maintained. Inspectors should also know how to read site plans and understand the relationship of the erosion and sediment control practices and other stormwater management activities with the overall plan.

Inspectors need communications skills so they can explain installation and maintenance problems to the contractor or owner and anyone else that “needs to know”. Also, inspectors must provide written reports to appropriate persons for their information or follow-up actions. Actions may include maintenance, repair or a request for a qualified design professional to assist, or for reporting to meet permit requirements. In summary, both written and verbal communication skills and an understanding of report requirements are essential tools for the inspector.

The credential requirement for inspecting construction sites in Alabama is stated in the NPDES General Permit for Construction administered by the Alabama Department of Environmental Management. Local government regulations may

require that persons providing inspection services have additional credentials or training to be designated as an inspector.

How Often Should Inspections be Made

In general, inspections should be made frequently and after major precipitation events. Since precipitation triggers inspections on permitted sites, a rain gauge is required.

Practices that can be damaged by construction activities need to be inspected on a regular basis, at least weekly and in some cases daily so the practices will be repaired or maintained and in good condition when a major precipitation event occurs. During periods of major precipitation events, practices need inspection daily.

Practices that are not normally affected by construction activities after installation need inspecting after each major precipitation event and as a minimum on a monthly basis. For vegetative practices, inspections should be made during early growth stages, regardless of precipitation events, to determine if reseeding is needed to ensure an adequate vegetative cover. Newly vegetated areas damaged by precipitation events should be repaired immediately after the area is determined to need repair.

The frequency requirement for inspecting construction sites in Alabama is stated in the NPDES General Permit for Construction administered by the Alabama Department of Environmental Management. Local governments may require inspections more frequently than is required by the State General Permit.

How are Practices Inspected

Visual evaluations are made of practices to determine their condition. Also, discharge points are reviewed to determine if sediment and turbid water are leaving the construction site.

Inspectors must know enough about the practices being inspected to make sound judgments about the need for repairs and maintenance. If there is any doubt about a situation, a more knowledgeable person should be requested to assist in the determination of appropriate actions. A good example of requesting another person for expert guidance is when a permanent seeding appears borderline and there is time to reseed before the recommended planting period ends.

Inspectors and others involved in erosion and sediment control activities must understand that erosion and sediment control plans are dynamic and usually need revising if construction involves more than a large lot and the construction period extends more than a few weeks. Inspectors should be encouraged to ask for assistance of design professionals if there are any reservations that a plan needs modifying.

Suggestions for Inspectors

- Study the erosion and sediment control and stormwater management plan. Identify the practices and schedule. Participate in pre-construction and construction conferences whenever possible.
- Review the site and practices with the plan in hand according to a predetermined schedule and the predetermined triggers.
- Start inspection at the site discharge points and work way up back to the site.
- Determine if the practices planned are installed properly and in the correct sequence.
- Determine if the practices appear in good condition (Do the practices need maintenance or repair?). This should be an objective comparison of what will be needed when major precipitation events occur.
- Determine if the system of practices appears to be effective for the construction site by examining discharge points. Evidence of ineffectiveness may be muddy or turbid water leaving the site or sediment deposits in the runoff conveyance system practices such as check dams and channels (swales).
- Determine if practices are effective during or immediately following a precipitation event. This is the best time to determine the effectiveness of the system and particularly to determine if turbid water is leaving the site.
- Determine if the site is managed to prevent a problem with debris, trash, petroleum products and chemicals (Are Groundskeeping and Spill Prevention practices used or needed?).
- Document relevant site information with photography.
- Complete or draft the appropriate inspection documents while on the site.

Discharge points should be examined objectively to determine if sediment deposits exist at adjacent off-site areas. Deposition of sediment indicates that erosion and sediment control may not be effective. An absence of deposits at discharge points (just below the outfall) where there is an opportunity for sedimentation to occur is a good indicator of an effective system. On the other hand, lack of sediment deposits at a point with high flow velocities will be less meaningful.

Inspections should be documented in a written report, log and/or checklist (See the following Example BMP INSPECTION REPORT). Whatever format is used

to document the inspection, the report should contain the site name, the date and time of inspection, the inspector and any other persons involved in the inspection, dates when key activities occurred (for example, grading the site and installing practices), comments or ratings concerning the success or failure of the practices, what corrective action(s) may be needed, what repairs or maintenance was done since the last inspection and verbal communications with the contractor or owner that took place during the inspection. In addition, there may be other items required by the permit holder or contractor.

Photography can be used very effectively to document the findings during an inspection and becomes important in the future as site conditions change and the practice(s) is no longer used or issues arise over the impacts of the site. Developing a comprehensive file of photographs that supports inspections is a sound business!

There is a range of formats used for documenting inspections. Two examples of inspection report forms are provided. The first form uses a detailed listing of practices to provide an efficient method for repeating the documentation at a site and may serve as a supplemental sheet to a more formal report form such as the ADEM Form 23 (<https://adem.alabama.gov/DeptForms/Form023.pdf>). It is important to recognize that local and state regulations may require a specific inspection form and this must be completed in addition to other formats that are used.

There is usually a permit requirement that a responsible person (representing the permit holder) sign an inspection report to acknowledge that they have been informed and understand what is needed to meet requirements for erosion and sediment control and stormwater management at a specific construction site.

BMP INSPECTION REPORT

Client _____ Project name _____ and Reg. no. _____

Inspected By _____ Date and Time _____ Page __ of __

A. Phase of Development: Initial Site Grading __ Building and Construction __ Punch List __

B. <u>BMPs Applied</u> (check all that apply)	<u>Condition of BMPs (check one)</u>			Comments
	<u>Good</u>	<u>Fair</u>	<u>Poor</u>	
<input type="checkbox"/> Construction Exit	___	___	___	
<input type="checkbox"/> Barrier-Class __ Silt Fence	___	___	___	
<input type="checkbox"/> Check Dams	___	___	___	
<input type="checkbox"/> Diversion	___	___	___	
<input type="checkbox"/> Grass Swale	___	___	___	
<input type="checkbox"/> Inlet Protection	___	___	___	
<input type="checkbox"/> Outlet Protection	___	___	___	
<input type="checkbox"/> Sediment Basin	___	___	___	
<input type="checkbox"/> Temporary Seeding	___	___	___	
<input type="checkbox"/> Permanent Seeding	___	___	___	
<input type="checkbox"/> Groundskeeping	___	___	___	

C. Additional BMPs needed (potential practice and location):

D. Additional Comments:

E. Sampling: Instream sampling necessary to evaluate the effectiveness of BMP implementation based on evaluation of qualified credentialed professional. Yes __ No __

F. Significant precipitation events since last inspection (date and amounts):

G. Inspection report reviewed with responsible owner/operator

Inspector _____ Date _____

Responsible owner/operator _____ Date _____

**ALABAMA DEPARTMENT OF ENVIRONMENTAL MANAGEMENT (ADEM)
NPDES CONSTRUCTION STORMWATER INSPECTION REPORT AND BMP CERTIFICATION**

Instructions: Please complete all questions. Respond with "N/A" as appropriate. Forms with incomplete or incorrect answers, or missing signatures will delay processing and may result in appropriate compliance action by the Department.

ITEM I.

Permittee Name:	Facility/Site Name:
Permit Number:	County:
Facility/Site Entrance Latitude & Longitude:	Phone Number:
Facility/Site Street Address or Location Description:	

ITEM II.

List name of current ultimate receiving water(s) (indicate if through MS4) and the number of disturbed acres which drains through each treatment system or BMP. Add additional sheet(s) if necessary.

Receiving Water	Disturbed Acres	Discharge Point #

ITEM III.

<input type="checkbox"/> YES <input type="checkbox"/> NO	1. Did discharges of sediment or other pollutants occur from the site? If "Yes", please list a description of the discharge(s) and their location(s):
<input type="checkbox"/> YES <input type="checkbox"/> NO	2. Were BMPs properly implemented and maintained at the time of inspection? If "No", please provide location(s) and descriptions of BMPs that need maintenance:
<input type="checkbox"/> YES <input type="checkbox"/> NO	3. Are BMPs needed in addition to those already present onsite at the time of inspection? If "Yes" please provide a description and location of additional BMPs that are needed:
<input type="checkbox"/> YES <input type="checkbox"/> NO	4. Have any BMPs failed to operate as designed? If "Yes", please provide location(s) and description of BMP(s) that failed:
<input type="checkbox"/> YES <input type="checkbox"/> NO	5. Were there BMPs required by the CBMPP that were not installed or installed in a manner not consistent with the CBMPP? If "Yes", please provide a description and location where the BMPs were not installed or installed incorrectly:

This Page Intentionally Left Blank