

REFERENCE PROJECT NO	FISCAL YEAR	SHEET NO

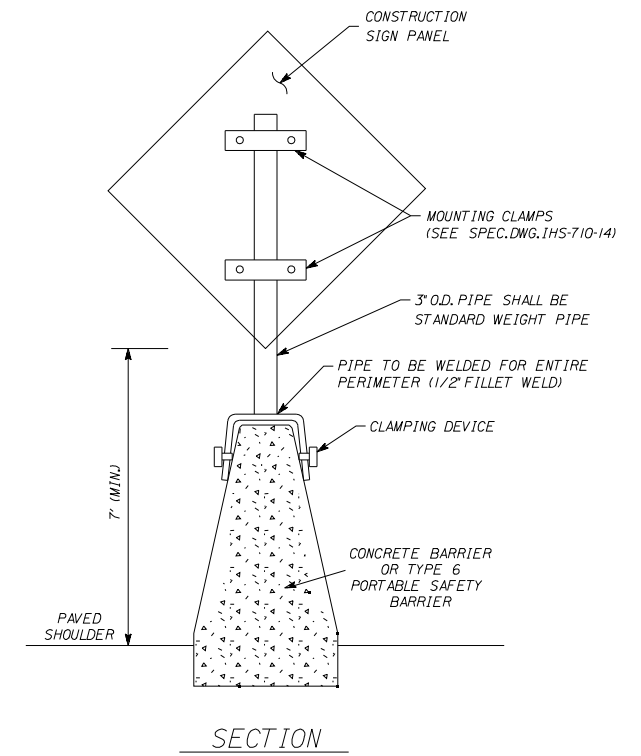

TEMPORARY SIGN MOUNTING DETAIL

NOTES:
 --THE COST OF MATERIALS AND LABOR FOR INSTALLING THIS ASSEMBLY SHALL BE A SUBSIDIARY OBLIGATION OF ITEM 740B-000.

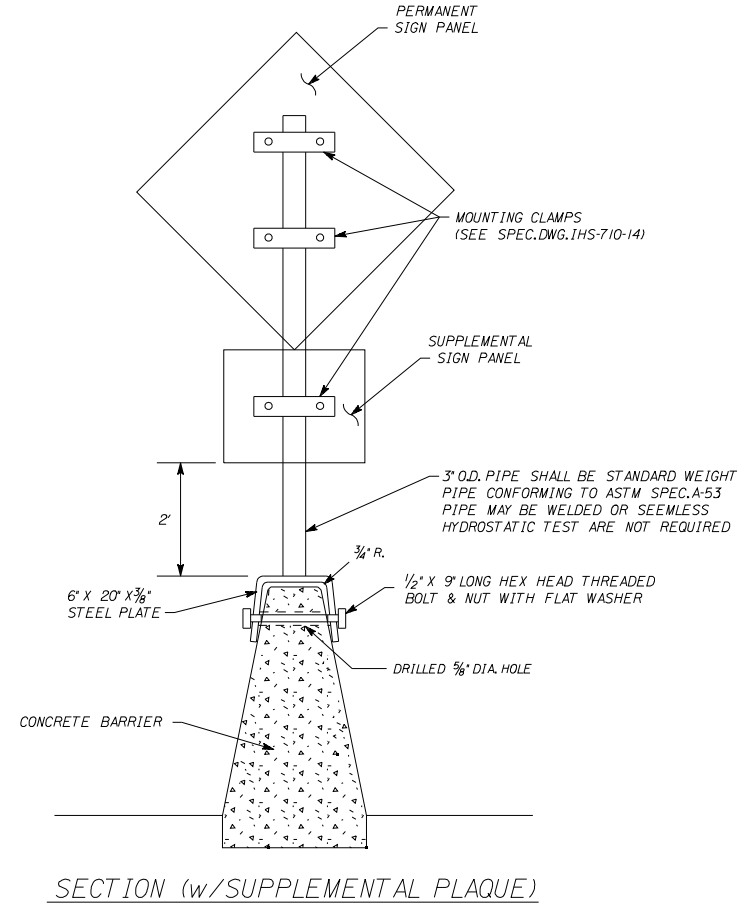
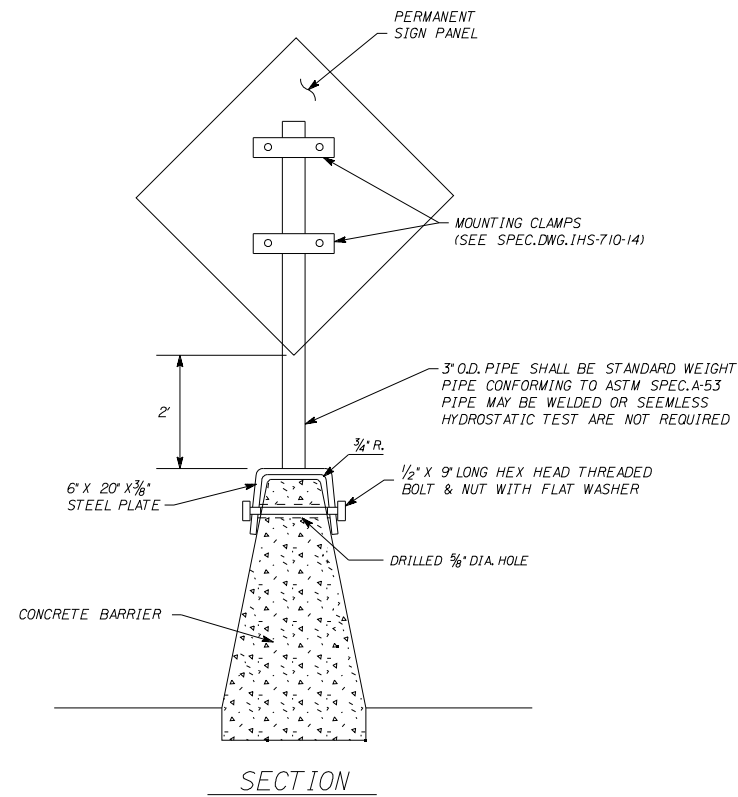
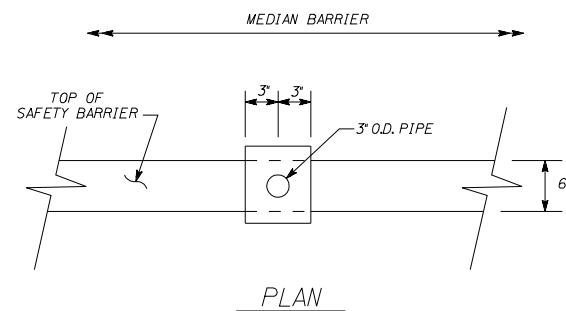
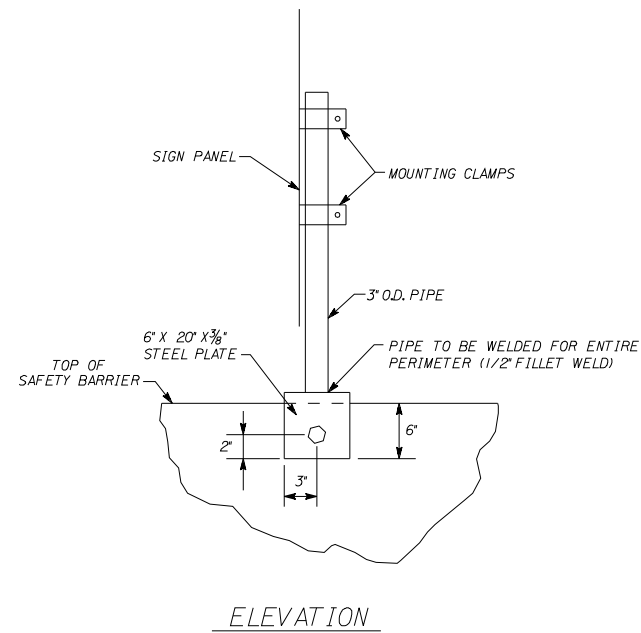

PERMANENT SIGN MOUNTING DETAILS

NOTES:
 --THE ENTIRE MOUNTING ASSEMBLY SHALL BE GALVANIZED AFTER FABRICATION IN ACCORDANCE WITH ASTM A-123.
 --THE COST OF ALL MATERIALS AND LABOR FOR INSTALLING THIS ASSEMBLY SHALL BE A SUBSIDIARY OBLIGATION OF ITEM 710B-004.
 --STEEL PLATE SHALL CONFORM TO ASTM A-36.

--SPECIFICATIONS-- CURRENT ALABAMA DEPARTMENT OF TRANSPORTATION		
THIS DRAWING REPRESENTS DESIGNS PREPARED FOR USE BY THE ALABAMA DEPARTMENT OF TRANSPORTATION AND IS NOT TO BE COPIED, REPRODUCED, ALTERED, OR USED BY ANYONE, OR ANY ORGANIZATION, WITHOUT THE EXPRESSED WRITTEN CONSENT OF THE ALABAMA DEPARTMENT OF TRANSPORTATION REPRESENTATIVE AUTHORIZED TO APPROVE THIS USE. ANYONE MAKING UNAUTHORIZED USE OF THIS DRAWING MAY BE PROSECUTED TO THE FULLEST EXTENT OF THE LAW.		
REVISIONS	 ALABAMA DEPARTMENT OF TRANSPORTATION 1409 COLISEUM BOULEVARD MONTGOMERY, AL 36130-3050 DESIGN BUREAU SPECIAL DRAWING	INDEX NO.
		DETAILS FOR MOUNTING SIGNS ON BARRIERS
DRAWN BY: _____ DATE DRAWN: 1-14-2013	SPECIAL DRAWING NO. SPECIAL PROJECT DETAIL	