

ALDOT-423
METHOD OF MEASURING THICKNESS AND WIDTH OF
TRAFFIC STRIPE and TRAFFIC CONTROL LEGENDS and MARKINGS

1. Scope

- 1.1. This test method covers the procedure for determining the thickness and width of traffic stripe (paint and thermoplastic) and the thickness of traffic control legends and markings (paint and thermoplastic).

2. Applicable Documents

- 2.1. Alabama Department of Transportation Standard Specifications
- 2.2. Form BMT 92

3. Apparatus

- 3.1. Micrometer capable of measuring to the nearest 0.001 (thousandths) of an inch. (fig.1, & fig. 2)
- 3.2. Tape Measure, capable of measuring to the nearest 0.1 inch
- 3.3. Whisk broom, or small handled broom to sweep away loose glass beads.

4. Sampling

- 4.1. Ten measurements shall be taken at each of 5 random locations throughout the project. The average of all measurements taken at the 5 random locations throughout the project shall be used in determining the acceptance and payment of the traffic stripe.

5. Procedure

5.1 Thermoplastic Material

- 5.1.1 All loose glass beads shall be swept from the area of measurement before thickness measurements are taken. Visual inspections with regard to the embedment of beads into the marking material should be made directly on the pavement surface. The specifications for bead embedment are general. It is

not feasible to obtain exact percentages of buried vs. non-buried beads.

5.1.2 Measure the stripe thickness to the nearest thousandths (0.001) of an inch with a bridge type micrometer (fig.1) for edge lines and a cantilever type micrometer (fig.2) for centerlines and markings and legends. Zero the micrometer prior to measuring by placing the micrometer on a solid, flat surface, turning the dial indicator to the zero point, and tightening the set screw.

5.1.3 For edge lines place the bridge type micrometer across the line and measure the thickness to the nearest 0.001". For centerlines place the cantilever type micrometer on the flat surface of the pavement beside the centerline stripe on the same side of the crown of the road that the stripe is on.

5.1.4 On open grade friction course, care must be taken to place the micrometer on as smooth a spot as possible to take the readings.

5.1.5 On new and existing surface treatments and on existing asphalt pavement surfaces that are only being striped it will be necessary to place a metal plate or tape across the stripe line at the five random locations to be measured in order to get correct thickness.

5.1.6 Measure the width of the stripe and legends and markings with a tape measure to the nearest (0.1) inch.

5.1.7 Record the measurement of the thickness and the width of the traffic stripe at the point of measurement.

5.2 Paint Material

5.2.1 Paint shall be applied at the rate (gallons/mile) required in the specifications.

5.2.2 Measure the width of the stripe and legends and markings with a tape measure to the nearest (0.1) inch.

5.2.3 Record the measurement of the width of the traffic stripe at the point of measurement.

6. Reporting

6.1. Report the measurement of the thickness, the width and location of the traffic stripe on form BMT 92. Record the thickness, the width and location of traffic control legends and markings on form BMT-92.

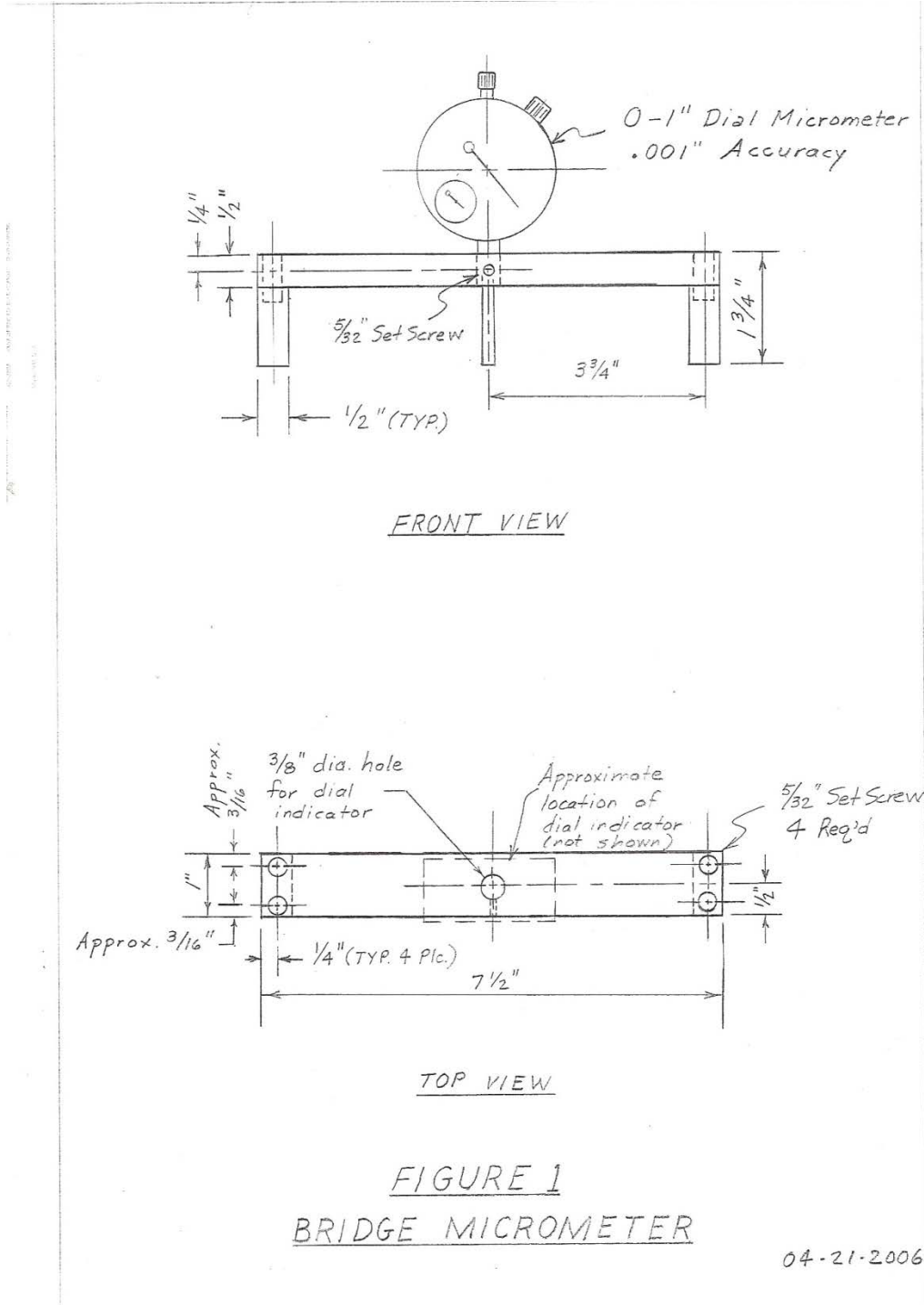

ALL INFORMATION CONTAINED HEREIN IS UNCLASSIFIED
 DATE 08-14-2012 BY 60322 UCBAW/SJS/STW
 EXEMPT FROM AUTOMATIC DOWNGRADING AND
 DECLASSIFICATION

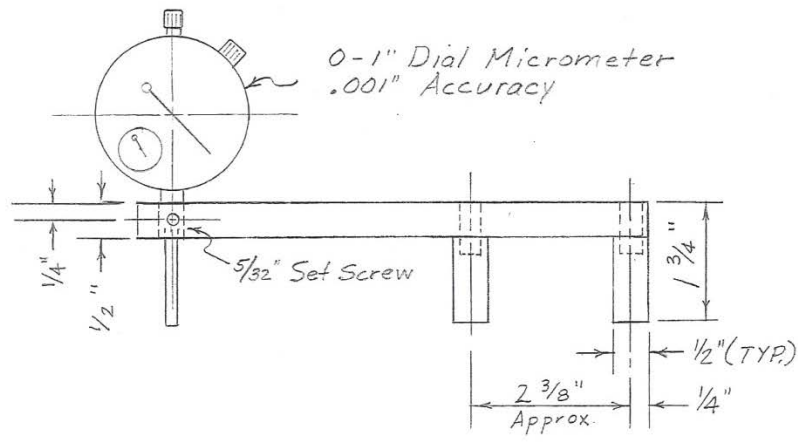

FRONT VIEW

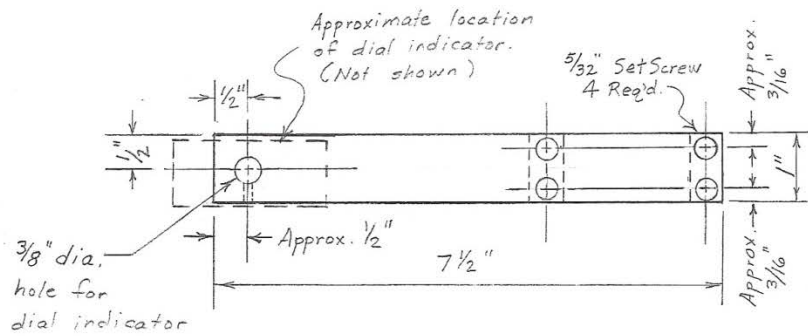

TOP VIEW

FIGURE 2
CANTILEVER MICROMETER

04-21-2006